

---

**TABLE OF CONTENTS**

<b>1</b>	<b>EXECUTIVE SUMMARY</b> .....	<b>1-9</b>
1.1	<i>Title &amp; location of project</i> .....	1-9
1.2	<i>Name of proponent</i> .....	1-9
1.3	<i>Name of organization preparing the report</i> .....	1-9
1.4	<i>A brief outline of proposal (type, process, technology and land requirements)</i> .....	1-10
1.5	<i>The major impacts &amp; recommendations for mitigation measures</i> .....	1-10
1.6	<i>Proposed monitoring</i> .....	1-16
<b>2</b>	<b>INTRODUCTION</b> .....	<b>2-17</b>
2.1	<i>Purpose of report</i> .....	2-17
2.2	<i>Identification of project and proponent</i> .....	2-18
2.2.1	<i>Project</i> .....	2-18
2.2.2	<i>Proponent</i> .....	2-18
2.3	<i>Details of consultant</i> .....	2-18
2.4	<i>Brief description of nature, size and location of project</i> .....	2-18
<b>3</b>	<b>SCREENING</b> .....	<b>3-19</b>
3.1	<i>EIA process</i> .....	3-19
3.1.1	<i>Overview of EIA</i> .....	3-19
3.1.2	<i>Objectives of EIA</i> .....	3-19
<b>4</b>	<b>SCOPING</b> .....	<b>4-21</b>
4.1	<i>Scope of EIA</i> .....	4-21
4.1.1	<i>Spatial scope</i> .....	4-21
4.1.2	<i>Temporal scope</i> .....	4-21
4.1.3	<i>EIA methodology</i> .....	4-22
4.1.4	<i>Scoping</i> .....	4-22
4.1.5	<i>Data collection</i> .....	4-22
4.1.6	<i>Baseline</i> .....	4-22
4.1.7	<i>Evaluation of alternatives</i> .....	4-23
4.1.8	<i>Stakeholder consultation</i> .....	4-23
4.1.9	<i>Impact assessment and mitigation</i> .....	4-23
4.2	<i>Important issues and concerns raised during consultation</i> .....	4-26
4.3	<i>Significant impacts and factors to be determined</i> .....	4-26

---

5	CONSIDERATION OF ALTERNATIVES .....	5-27
5.1	Site alternatives (selection and rejection criteria).....	5-27
5.2	Design/technology alternatives (selection and rejection criteria).....	5-27
5.3	Environmental alternatives (selection and rejection criteria).....	5-27
5.4	Economic alternatives (selection and rejection criteria).....	5-27
6	DESCRIPTION OF PROJECT .....	6-28
6.1	Type & category of project .....	6-28
6.2	Objectives of project .....	6-28
6.3	Location and site layout of project .....	6-28
6.4	Land use on the site.....	6-29
6.5	Road access.....	6-29
6.6	Vegetation features of the site.....	6-29
6.7	Cost and magnitude of operation.....	6-29
6.8	Schedule of implementation .....	6-30
6.9	Description of the project (process flow chart/steps, technology, raw material and products, by-products).....	6-30
6.9.1	Raw materials source, quantifications & list of machineries .....	6-30
6.9.2	List of machineries to be installed .....	6-30
6.9.3	Production process and by-products & technology (Electric Induction Furnace).....	6-31
6.9.4	Process flow diagrams .....	6-32
6.9.5	Pollution control technologies .....	6-32
6.10	Restoration and rehabilitation plans .....	6-34
6.11	Government approvals.....	6-35
7	DESCRIPTION OF ENVIRONMENT .....	7-36
7.1	Baseline physical environment.....	7-36
7.2	Methodology .....	7-36
7.3	Data collection.....	7-36
7.4	Social survey .....	7-37
7.5	Review of Legal and Administrative Framework.....	7-37
7.6	Baseline Physical Environment .....	7-37
7.7	Topography.....	7-38
7.7.1	Hydrology .....	7-38

---

7.7.2	<i>Seismicity</i> .....	7-38
7.7.3	<i>Geography</i> .....	7-38
7.7.4	<i>Climate</i> .....	7-39
7.7.5	<i>Geography</i> .....	7-39
7.7.6	<i>Climate</i> .....	7-40
7.7.7	<i>Wind</i> .....	7-42
7.7.8	<i>Ecological Environment</i> .....	7-42
7.7.9	<i>Aquatic Flora &amp; Fauna</i> .....	7-42
7.7.10	<i>Flora</i> .....	7-42
7.7.11	<i>Fauna</i> .....	7-43
7.8	<i>Baseline Socio-Economic Environment</i> .....	7-44
7.8.1	<i>Socio-Economic Profile of Study Area</i> .....	7-44
7.8.2	<i>Study Area Profile</i> .....	7-44
7.8.3	<i>Demographic Profile</i> .....	7-46
7.8.4	<i>Health Facilities</i> .....	7-46
7.8.5	<i>Educational Facilities</i> .....	7-46
7.8.6	<i>Demographic Characteristics Of The Population</i> .....	7-46
7.8.7	<i>Family Size</i> .....	7-47
7.8.8	<i>Age Groups</i> .....	7-47
7.8.9	<i>Occupation of Respondents</i> .....	7-47
7.8.10	<i>Literacy RATE</i> .....	7-48
7.8.11	<i>Common Diseases</i> .....	7-48
7.8.12	<i>Cultural, Religious &amp; Other Structures</i> .....	7-49
7.9	<i>Socioeconomic Survey and Public Consultation</i> .....	7-49
7.10	<i>Methods of Public Consultation</i> .....	7-49
7.11	<i>Project Response</i> .....	7-49
7.12	<i>Lab Reports</i> .....	7-50
7.13	<i>Suitability of Site</i> .....	7-50
8	<b>IMPACT ASSESSMENT</b> .....	8-51
8.1.1	<i>Methodologies for impact identification</i> .....	8-51
8.1.2	<i>Checklist</i> .....	8-53

8.2	<i>Characteristics of impacts (nature, magnitude, extent and location, timing, duration, reversibility and risk).....</i>	8-56
9	<b>SCREENING OF POTENTIAL ENVIRONMENTAL IMPACTS AND MITIGATION MEASURES</b>	9-58
9.1	<i>Impacts associated with project activities.....</i>	9-58
9.2	<i>Project location.....</i>	9-58
9.2.1	<i>Compensation in money terms .....</i>	9-58
9.2.2	<i>Replacement/relocation/rehabilitation .....</i>	9-58
9.3	<i>Project design .....</i>	9-59
9.4	<i>Construction phase .....</i>	9-59
9.4.1	<i>Mitigation measures.....</i>	9-59
9.4.2	<i>Impacts on vegetation .....</i>	9-60
9.4.3	<i>Impacts on water sources.....</i>	9-60
9.4.4	<i>Mitigation measures for water .....</i>	9-60
9.4.5	<i>Impacts on air quality .....</i>	9-60
9.4.6	<i>Mitigation measures for ambient air quality .....</i>	9-61
9.4.7	<i>Impacts due to noise.....</i>	9-61
9.4.8	<i>Mitigation for noise.....</i>	9-61
9.4.9	<i>Impacts on socio-economic environment .....</i>	9-62
9.4.10	<i>Mitigation measures.....</i>	9-62
9.5	<i>Operational phase.....</i>	9-62
9.5.1	<i>Water consumption .....</i>	9-62
9.5.2	<i>Mitigation measures.....</i>	9-62
9.5.3	<i>Wastewater.....</i>	9-63
9.5.4	<i>Mitigation measures.....</i>	9-63
9.5.5	<i>Noise .....</i>	9-63
9.5.6	<i>Mitigation measures.....</i>	9-63
9.5.7	<i>Waste management .....</i>	9-64
9.5.8	<i>Air emissions.....</i>	9-65
9.5.9	<i>Mitigation measures.....</i>	9-65
9.5.10	<i>Emergency response .....</i>	9-66
9.5.11	<i>Mitigation measures.....</i>	9-66
9.5.12	<i>Occupational hazards .....</i>	9-66

---

9.5.13	Mitigation measures.....	9-67
9.6	Potential environmental enhancement measures.....	9-67
9.7	Building enhancement.....	9-68
9.7.1	Social enhancement measures .....	9-68
9.7.2	Employment/poverty alleviation.....	9-68
9.7.3	Local economy .....	9-68
10	ENVIRONMENTAL MANAGEMENT AND MONITORING PROGRAM .....	10-69
10.1	Purpose and objective of the EMP .....	10-69
10.2	Components of the EMP.....	10-69
10.3	Legislation and guidelines .....	10-70
10.4	Description of proposed mitigation actions.....	10-70
10.5	Schedule of implementation and environmental budget .....	10-78
10.5.1	Schedule of implementation .....	10-78
10.5.2	Environmental budget.....	10-78
10.6	Environmental management team along with their roles and responsibilities .....	10-79
10.7	Proposed monitoring program to assess performance or output of EMP .....	10-82
10.8	Compliance monitoring.....	10-82
10.9	Effects monitoring.....	10-82
10.10	Proposed EMP reporting and reviewing procedures .....	10-86
10.11	Training needs .....	10-86
10.12	Objectives of the training program .....	10-86
10.13	Objectives of the training program .....	10-86
10.14	Training schedule.....	10-86
11	STAKEHOLDER’S CONSULTATION.....	11-89
11.1.1	Consultation mechanism.....	11-89
11.2	Proponent’s environmental management team.....	11-90
11.3	The responsible authority.....	11-91
11.4	The other departments and agencies .....	11-91
11.5	Environmental practitioners and experts.....	11-91
11.6	Affected and wider community.....	11-92
12	CONCLUSION AND RECOMMENDATION .....	12-95
13	APPENDICES.....	13-96

---

13.1	<i>Glossary</i> .....	13-96
13.2	<i>LIST OF ABBREVIATIONS</i> .....	13-99
13.3	<i>LIST OF INDIVIDUALS AND ORGANIZATIONS CONSULTED ALONG WITH THEIR WRITTEN FEEDBACK</i> .....	13-101
13.4	<i>SOURCES OF DATA AND FULL LIST OF ALL REFERENCE MATERIAL USED</i> .....	13-103
13.5	<i>TERMS OF REFERENCES</i> .....	13-104
13.6	<i>LIST OF NAME, QUALIFICATION AND ROLES OF TEAM MEMBERS CARRYING OUT IN IEE/EIA STUDY</i> .....	13-105
13.7	<i>APPROVALS FROM OTHER CONCERNED DEPARTMENT</i> .....	13-107

---

**LIST OF FIGURES**

*Figure 1: Location map of site..... 6-29*

*Figure 2: Road access map..... 6-29*

*Figure 3: Process flow diagram ..... 6-32*

*Figure 4: Dry Scrubber working principle..... 6-33*

*Figure 5: Dry scrubber preliminary design..... 6-34*

*Figure 6: Seismic Zones of Pakistan ..... 7-39*

*Figure 7: Average Annual Temperatures and precipitation in Kasur..... 7-41*

*Figure 8: Maximum temperature ranges in Kasur ..... 7-41*

*Figure 9: Annual Precipitation amounts in Kasur ..... 7-42*

*Figure 10: Annual average wind speed in Kasur ..... 7-42*

*Figure 11: Consulted age groups in the area near project site..... 7-47*

*Figure 12: Occupation of Respondents ..... 7-48*

*Figure 13: Literacy Rate..... 7-48*

*Figure 14: Percentage of people in favor or against the project ..... 7-50*

---

**LIST OF TABLES**

---

<i>Table 1: Salient features of project.....</i>	<i>1-9</i>
<i>Table 2: Impacts and mitigation measures.....</i>	<i>1-12</i>
<i>Table 3: Impact Assessment Approach.....</i>	<i>4-24</i>
<i>Table 4: Raw materials.....</i>	<i>6-30</i>
<i>Table 5: List of machineries.....</i>	<i>6-30</i>
<i>Table 6: Flora of the Study Site.....</i>	<i>7-43</i>
<i>Table 7: Mammals in study area.....</i>	<i>7-43</i>
<i>Table 8: Study Area Profile.....</i>	<i>7-44</i>
<i>Table 9: Impact significance criteria.....</i>	<i>8-51</i>
<i>Table 10: Impact matrix checklist for construction phase.....</i>	<i>8-53</i>
<i>Table 11: Impact assessment checklist for operational phase.....</i>	<i>8-55</i>
<i>Table 12: Impact assessment characteristics.....</i>	<i>8-56</i>
<i>Table 13: Description of proposed mitigation actions.....</i>	<i>10-71</i>
<i>Table 14: Management and Monitoring Plan – Operation.....</i>	<i>10-75</i>
<i>Table 15: Cost breakup of environmental budget.....</i>	<i>10-78</i>
<i>Table 16: Roles &amp; responsibilities of environmental management team.....</i>	<i>10-79</i>
<i>Table 17: Environmental monitoring plan.....</i>	<i>10-84</i>
<i>Table 18: Training needs.....</i>	<i>10-87</i>
<i>Table 19: Consultation with environmental practitioners and experts.....</i>	<i>11-91</i>

## 1 EXECUTIVE SUMMARY

This executive summary presents the min findings of Environmental Impact Assessment (EIA) of Ansari Foundry “Steel Furnace” Engineering and Melting at Multan road Adda Gulshan, Jumber, Tehsil Pattoki, District Kasur. The main objective of this proposed project is, production of Auto parts with the help of furnace melting.

### 1.1 Title & location of project

Ansari Foundry “Steel Furnace” Engineering and Melting at Multan road Adda Gulshan, Jumber, Tehsil Pattoki, District Kasur

### 1.2 Name of proponent

Muhammad Javaid Iqbal

R/o Dak-khana khass, Jumhar Khoro, Tehsil Pattoki, District Kasur

CNIC No: 35103-3838209-9

### 1.3 Name of organization preparing the report

Ansari Foundry “Steel Furnace” Engineering and Melting has engaged Environtech Consultants (Private) Limited at office no. 11, Second Floor, Centre Point Plaza, Main Boulevard, Gulberg-III, Lahore.

**Table 1: Salient features of project**

Salient features of project		
1.	Total Area	2 Kanals
2.	Cost of the project	Pkr/- 90 Million approx.
3.	Capacity of project	100 tons/month
4.	Product	Auto parts
5.	Raw Materials	Iron Scrap, Cast Iron
6.	Quantification of Raw Materials	80 tons/day
7.	Storage capacity	100 tons/day
8.	Total Capacity	100 tons/month
9.	Location of project	31°08'53.0"N 73°55'01.6"E
10.	Nature of area	Agricultural cum industrial

<b>11.</b>	Present status of land Use	Vacant Plot
<b>12.</b>	Land use in the surroundings of project site.	The surroundings are: North Industrial Unit South Agricultural Land East Industrial Unit West Local roads and Industrial unit
<b>13.</b>	Description of proposed project	The proposed project is the establishment of steel Furnace
<b>14.</b>	Nearby emergency services i.e. Hospital, police station, rescue, fire brigade etc.	THQ Pattoki, Cardiac Centre Chunian, Rescue 1122, Police Station
<b>15.</b>	Water Source	Ground Water
<b>16.</b>	Status of Project	Open Land
<b>17.</b>	Source of Power	LESCO (Lahore Electric Supply Company)

#### 1.4 A brief outline of proposal (type, process, technology and land requirements)

As per Punjab Environmental Protection Act 1997 (amended 2012) and Initial Environmental Examination (IEE) & Environmental Impact Assessment (EIA) Regulations, 2000 proposed project falls under Category C (2) “*Mining and processing of major non-ferrous metals, iron and steel rolling*” mentioned in Schedule-II. Thus, requires an EIA.

The current project is about establishment of steel mill. Site selected for proposed project is under the ownership of proponent. It is an environmentally friendly project which will produce quality steel for development projects. The estimated project cost is **PKR 90 Million approx.**, and capacity of project will be **100 tons/month**. The project under consideration of this EIA is the establishment of steel mill which is located at Ansari Foundry “Steel Furnace” Engineering and Melting located Multan road Adda Gulshan, Jumber, Tehsil Pattoki, District Kasur Beyond this scope no other development activities have been covered in this EIA study.

#### 1.5 The major impacts & recommendations for mitigation measures

The potential impacts associated with the proposed project construction and operation activities

Included: increase in water consumption; surface water contamination, air pollution from vehicle; vehicle movement, noise and disturbance, soil contamination and waste generation.

Proposed installations are automated machineries to be laid on concrete fortifications. The machinery installation does not require water while only water use will be during washing and domestic activities. Water conservation practices will be utilized to reduce the overall water consumption during proposed project activities. Surface or groundwater quality may deteriorate if pollutants are mixed with surface runoff during rain and carried to water resources in the vicinity or seeped in the ground. The impermeable septic tank will prevent untreated sewage from polluting surface water.

The ambient air quality of the area can be affected by exhaust emissions, vehicles and combustion process in construction equipment. The pollutants can seriously impair human health and ecological environment and other materials. The emissions include Sulphur dioxide, oxides of nitrogen, carbon monoxide, carbon dioxide, and particulates. The emission levels depend on the type and size of activity, the type and quality of fuel and the manner in which it is burned. A significant impact will be interpreted if the concentration of pollutants in the ambient air exceeds the PEQS or recognized international guidelines for ambient air quality.

The sources of emissions during construction activities will not be significantly enough to alter the ambient air quality at regional level. All vehicles, equipment and machinery will be properly tuned and maintained to minimize emissions. Cleaner fuels if required (less 1% Sulphur content) will be preferred to procure. Monitoring of Ambient air parameters and emissions should be carried out on to ensure compliance with the PEQS.

Noise has the potential to cause an impact to nearby communities and working personnel. To avoid the impact of noise, it will be ensured that, vehicles and other potentially noisy equipment used are in good condition. The noise level monitoring results would be compared with Punjab Environmental Quality Standards (PEQS) for Noise to meet the permissible limits. All on-site personnel will use required personal protective equipment (PPE) in high noise areas that will be clearly marked.

All the waste generated during construction & installation activities will be disposed-off through implementation of an effective waste management plan to ensure that any impact resulting from

waste generation shall be minimal. The recyclable waste will be sold to waste contractors, as per waste management plan. No hazardous chemical will be uncontrollably discharged into the Environment.

**Table 2: Impacts and mitigation measures**

Environmental Aspect	Potential Impacts	Mitigation Measures
Water Resources	Depletion in groundwater, contamination of water resources by surface runoff, spillage of fuel	<ul style="list-style-type: none"> <li>▪ Water extraction will be kept at minimum and water conservation measures will be practiced.</li> <li>▪ Sewerage Wastewater from project site will be directed to settling tanks.</li> <li>▪ Fuels and lubricants will be stored in covered and with bund walls, underlain with impervious lining.</li> </ul>

		<ul style="list-style-type: none"> <li>▪ Spill prevention plan shall be followed to mitigate any kind of spill.</li> </ul>
Air Quality	Dust, combustion emissions, vehicular emissions used for project-related activities.	<ul style="list-style-type: none"> <li>▪ Water will be sprinkled daily on all exposed surfaces to suppress emission of dust.</li> <li>▪ Regular maintenance of project vehicles and equipment to ensure that engines are in sound working condition to minimize air emissions.</li> <li>▪ Use of cleaner fuels for combustion</li> <li>▪ Ambient monitoring should be carried out to ensure compliance with the PEQS.</li> </ul>
Noise	Disturbance to the site workers, Nuisance for surrounding communities and wildlife	<ul style="list-style-type: none"> <li>▪ Proper maintenance of vehicles and potentially noisy equipment.</li> </ul>

		<ul style="list-style-type: none"> <li>▪ Minimize/avoid unnecessary use of noisy machinery.</li> <li>▪ Blowing of horn will be prohibited.</li> <li>▪ Provision of Personal Protective Equipment (PPE) to the on-site personnel in high noise areas.</li> </ul>
Solid Waste	Soil contamination, air pollution, odor, health hazards, aesthetic issues	<ul style="list-style-type: none"> <li>▪ Recyclable material will be separated at source and will be used again in manufacturing process.</li> </ul>
Worker’s Health and Safety	Health problems or immediate risk may take place, Occupational health of workers and community may be affected.	<ul style="list-style-type: none"> <li>▪ Compliance to emergency response plan for emergencies and accidents will be ensured to avoid health safety risks.</li> <li>▪ Work safety measures and good workmanship practices are to be</li> </ul>

		<p>followed by the contractor to ensure no health risks for laborers.</p> <ul style="list-style-type: none"> <li>▪ Protection devices (earmuffs) will be provided to the workers operating in the vicinity of high noise generating machines.</li> <li>▪ Proper maintenance of facilities for workers will be monitored.</li> <li>▪ Provision of protective clothing for laborers e.g. helmet, adequate footwear, protective goggles, gloves</li> <li>▪ Ensure strict use of wearing PPE during work activities.</li> </ul>
--	--	---

		<ul style="list-style-type: none"> <li>▪ Provision of proper safety signage at sensitive/accident prone spots.</li> </ul>
--	--	---

### 1.6 Proposed monitoring

To monitor actual impacts of the project on selected sensitive receptors so that impacts not anticipated in the EIA or impacts which exceed the levels anticipated in the EIA can be identified and appropriate mitigation measures can be adopted in time. This objective will be achieved through effects monitoring.

Considering the environmental conditions of the project area and the assessment of potential impacts of the project made in the EIA, the following environmental parameters will be monitored at identified locations.

**Air Quality Monitoring** – Air quality monitoring will be done during the construction and operation phase of the project at the representative locations. Ambient air quality parameters will include NO<sub>x</sub>, SO<sub>x</sub>, CO and PM<sub>10</sub>.

**Water Quality Monitoring** – Ground and surface water quality monitoring will be done during the construction and operation phase of the project at the representative locations.

**Groundwater Quality Parameters:** Total Coliforms, Total Colonial Count, E-Coli, pH, TDS, Total Hardness, Nitrate, Chloride, Fluoride, Colour, Manganese, Aluminium, Chromium, Cadmium, Boron, Barium, Antimony, Arsenic, Cyanide, Mercury, Nickel.

**Wastewater Quality Parameters:** pH, DO, TSS, Alkalinity, BOD<sub>5</sub>, COD, Turbidity.

**Noise Monitoring** - The monitoring will be carried out at key locations covering all receptors

---

## 2 INTRODUCTION

---

This chapter of the report provides a brief description of nature, size and location of the project. A defined scope of study, the magnitude of efforts and concise description of project proponent is also included in this chapter. The project is being proposed with the objectives to meet the consumers’ increased demand for high quality steel, keeping in view the business sustainability and to maintain workplace safety. Project proponent aims to deliver sustainable, industry leading financial performance and earn trust through enhancing quality of life and contributing to a healthier future.

The study has been carried out to estimate the potential environmental impacts, both positive and negative, on the environment as well as socio-economic fabric of the surrounding environment during construction as well as operational phase. This report intends to provide satisfactory mitigation measures to avoid/eliminate any chance of adverse environmental impact on the socio-cultural, economic and environmental components. This report also intends to fulfill the regulatory requirements set under Punjab Environmental Protection Act, 1997 (Amended 2012) and its consequent legislative framework for IEE/EIA Regulations 2000 and the guidelines drafted for IEE and EIA under numerous sectorial heads. The entire set of legislative framework requires any new development project to undergo an IEE or EIA based on the categorization of the project under Schedule I and/or Schedule II.

### 2.1 Purpose of report

As per Punjab Environmental Protection Act, 1997 (Amended 2012) and the IEE/EIA Regulations, 2000 it is mandatory for the proponent of any development project to obtain Environmental Approval before commencing construction from EPA Punjab by filing an IEE or EIA as the case may be before the Agency. This EIA Study presents the findings of this proposed unit. For this purpose, the proponent has engaged environmental consultants, M/s Environtech Consultants (Private) Limited. The purpose of this study is to identify the environmental baseline i.e. physical, biological and socio- economic/cultural conditions and assess all possible impacts arising during the construction and operation phase of the project with the aim to find out appropriate measures for their mitigation, to either eliminate those impacts or to bring them to acceptable level and formulate Environmental Management and Monitoring Plan (EMMP) for implementation of the project in environment-friendly manner. This EIA Report provides relevant information, as

required under the officially approved format, to facilitate the decision makers i.e. EPA Punjab for the issuance of Environmental Approval/NOC.

## **2.2 Identification of project and proponent**

### *2.2.1 Project*

The proposed project to which this Environmental Impact Assessment (EIA) relates is entitled as “Ansari Foundry “Steel Furnace” Engineering and Melting located Multan road Adda Gulshan, Jumber, Tehsil Pattoki, District Kasur

### *2.2.2 Proponent*

Muhammad Javaid Iqbal

R/o Dak-khana khass, Jumhar Khoro, Tehsil Pattoki, District Kasur

CNIC No: 35103-3838209-9

## **2.3 Details of consultant**

The EIA study was carried out by team of Envirotech Consultant Private Limited comprising of environment scientists and engineers, sociologist, environmental chemist and environmental auditors with diversified experience on local and international assignments. The detail of the project team deputed on this assignment is attached to this report.

## **2.4 Brief description of nature, size and location of project**

The proposed project to which this Environmental Impact Assessment (EIA) relates is entitled as Ansari Foundry “Steel Furnace” Engineering and Melting located Multan road Adda Gulshan, Jumber, Tehsil Pattoki, District Kasur The total area of proposed project is **2 Kanals** with total cost of Pkr 90 Million approx. capacity of project will be 100 tons/month. The project under consideration of this EIA is the establishment of steel furnace which is located at located Multan road Adda Gulshan, Jumber, Tehsil Pattoki, District Kasur. Beyond this scope no other development activities have been covered under this EIA study.

---

### 3 SCREENING

---

**According to the Section 12 of Punjab Environmental Protection Act, 1997 (amended 2012) which states;**

*“No proponent of a project shall commence construction or operation unless he has filed with the Government Agency designated by Federal Environmental Protection Agency or Provincial Environmental Protection Agencies, as the case may be or where the project is likely to cause an adverse environmental effects an Environmental Impact Assessment (IEE) and has obtained from the Government Agency approval in respect thereof.”*

As per Punjab Environmental Protection Act 1997 (amended 2012) and Initial Environmental Examination (IEE) & Environmental Impact Assessment (EIA) Regulations, 2000 proposed project falls under **Category C (2) “Mining and processing of major non-ferrous metals, iron and steel rolling”** mentioned in Schedule-II. Thus, requires an EIA Report is being prepared for duly submission in EPA, Punjab.

#### **3.1 EIA process**

##### **3.1.1 Overview of EIA**

EIA is a systematic process to identify, predict and evaluate the environmental impacts of proposed actions and projects. The process is applied prior to major decisions and commitments being made. Wherever appropriate, social, cultural and health effects are considered as an integral part of EIA. Particular attention is given to practical implementation of EIA to prevent and mitigate significant adverse effects of proposed undertakings.

##### **3.1.2 Objectives of EIA**

The overall objective of the EIA is as follows:

- Description of the proposed project, including an estimate of emissions, effluent and waste and consideration of the project alternatives;
- Identify and investigate all impacts of the proposed project on the physical, biological, and socio- economic environment;
- Evaluation of the baseline environmental conditions in the impact zone to provide a basis for assessing the incremental impacts of the proposed project, including existing pollution levels and nuisance conditions;

- Identification and assessment of the potential impacts on the environment during each of the project phases;
- To propose mitigation measures that would help the Project Proponent in conducting the operation in an environmental sustainable manner; and
- To develop an Environmental Management Plan that would assist the Project Proponent in the effective implementation of the recommendations of the EIA.

---

## 4 SCOPING

---

Project land is owned by project proponent. Impacts have been assessed for the immediate and direct area of influence of the project defined as:

- Immediate Area of Influence: Within the proposed project site boundary.
- Direct Area of Influence: Within 1 Km from the proposed project site boundary.

Effects on socioeconomic receptors and resources have been assessed for the construction and operational phases of the proposed project. The proposed project activities are predicted to last for a period of 5-6 months within which the potential impacts have been assessed. The operational impacts have been assessed for the entire lifespan of the facility. The impacts related to the decommissioning of the proposed project will be assessed at the time of decommissioning which will involve carrying out site assessment study at the proposed project location.

Project location is given in below figure:

### 4.1 Scope of EIA

This consolidated EIA report covers the examination of physical, biological, environmental and socioeconomic impacts of the proposed project

The spatial and temporal scope of the project is described below:

#### 4.1.1 Spatial scope

Impacts have been assessed for the immediate and direct area of influence of the project defined as:

- Immediate Area of Influence: Within the proposed project site boundary.
- Direct Area of Influence: Within 1 Km from the proposed project site boundary.

#### 4.1.2 Temporal scope

Effects on socioeconomic receptors and resources have been assessed for the construction and operational phases of the proposed project. The proposed project activities are predicted to last for a period of 5-6 months within which the potential impacts have been assessed. The operational impacts have been assessed for the entire lifespan of the facility. The impacts related to the decommissioning of the proposed project will be assessed at the time of decommissioning which will involve carrying out site assessment study at the proposed project location.

#### ***4.1.3 EIA methodology***

The EIA project passes through series of stages prior to attaining approval from relevant environmental protection agency. The EIA process and the approach followed for the proposed project is defined below:

#### ***4.1.4 Scoping***

Scoping is an early stage in the process and is designed to ensure that the environmental studies provide all the relevant information on:

- The impacts of the project, in particular focusing on the most important impacts;
- The alternatives to the project;
- Other environmental sensitivities to be addressed at early stage.

The EIA process started with the scoping study. The purpose of scoping was to identify:

- Important issues to be considered in an EIA;
- Appropriate time and space boundaries of the EIA study;
- Information necessary for decision-making;
- Significant effects and factors to be studied in detail.

The scoping was followed by data collection describes in subsequent section.

#### ***4.1.5 Data collection***

Following literature reviews and data collection was carried out for EIA:

- A generic description of the proposed project and its related activities was collected from the proponent.
- Legislative review of the applicable laws, regulations, guidelines and standards from literature search.
- Baseline of the area’s environmental and socio-economic settings was collected through literature search and field surveys.

#### ***4.1.6 Baseline***

The environmental impact is measured through a change in the environment, resulting from a designated action or activity. In order to identify such a change, it is essential to have as complete as practicable understanding of the nature of the existing environment, prior to its interaction with the proposed activity. This translates into the need to characterize the existing baseline environmental conditions, including establishing prevailing conditions for a range of environmental

media, particularly air, water, soil and groundwater, flora and fauna and the human environment. This was achieved through a detailed review of all secondary resources (i.e. existing documentation and literature); and the undertaking of project specific baseline studies and surveys to collect supplementary data in the following areas:

- Geology;
- Flora and fauna;
- Water quality characteristics;
- Traffic;
- Ambient air quality;
- Noise conditions;
- Socio-economic conditions;
- Archaeology.

Both the existing secondary sources and literature studies were conducted and integrated into one coherent description of baseline characteristics.

#### ***4.1.7 Evaluation of alternatives***

To establish an environmentally sound preferred option for achieving the objectives of the proposed project, different alternatives including site selection, raw material and technology alternatives were studied in collaboration with the project proponent. Technology selection was made taking in to consideration environmentally, economically and socially suitable as well as technically feasible options.

#### ***4.1.8 Stakeholder consultation***

Stakeholder consultation was carried out for the proposed project with primary and secondary stakeholders of the project. Following steps were involved to attain stakeholder consent:

- Providing information on the proposed project activities;
- Identifying the stakeholders concerns, expectations and apprehensions about the proposed project;
- Summarizing the process outcome.

#### ***4.1.9 Impact assessment and mitigation***

The information collected in the previous phases was used to assess the potential environmental

impacts of the proposed project activities. The impact assessment approach is provided in **Table 3**. Impacts of project activities on environment. The issues studied during impact assessment include potential impacts on:

- Physical environment of the area
- Biological environment of the area
- Socio-economic environment of the area

**Table 3: Impact Assessment Approach**

Impact Characteristics	Categorise
<b>Nature of the Impact</b>	<p><b>Direct:</b> The environmental parameter is directly changed by the project.</p> <p><b>Indirect:</b> the environmental parameter changes as a result of change in another parameter.</p>
<b>Duration of the impact</b>	<p><b>Short term:</b> Lasting only till the duration of the project such as noise from the construction activities.</p> <p><b>Medium term:</b> Lasting for a period of few months to a year after the project before naturally reverting to the original condition.</p> <p><b>Long term:</b> Lasting for a period much greater than medium term impacts before naturally reverting to the original condition.</p>
<b>Geographical Location of the impact</b>	<p><b>Local:</b> Within the area of project i.e. operation site and access road.</p> <p><b>Regional:</b> Within the boundaries of the project area.</p> <p><b>National:</b> Within the boundaries of the country.</p> <p><b>Global:</b> Trans-boundary impacts</p>
<b>Timing</b>	<p>Construction</p> <p>Operation</p>
<b>Likelihood of the impact</b>	<p><b>High:</b> High likelihood of occurrence during lifetime of operation, Regular/continuous part of operations.</p> <p><b>Moderate:</b> Moderate possibility of occurrence during lifetime of operation, Periodic/occasional part of operations.</p>

	<b>Low:</b> Unlikely to occur during lifetime of operation.
--	---

Impact Characteristics	Categorise
<b>Reversibility of the impact</b>	<p><b>Reversible:</b> When a receptor resumes its pre-project condition.</p> <p><b>Irreversible:</b> When a receptor does not or cannot resume its pre-project condition.</p>
<b>Significance of the impact</b>	<p><b>Major, Moderate, Minor, Negligible and Beneficial</b> Based on the consequence, likelihood, reversibility, geographical extent, duration, level of public concern and conformance with legislative or statutory requirements.</p>
<b>Consequence severity of impact</b>	<p><b>High:</b></p> <ul style="list-style-type: none"> <li>▪ Serious/catastrophic damage to environment</li> <li>▪ Direct legislative requirement</li> <li>▪ Corporate requirement</li> <li>▪ Serious threat to corporate reputation/profitability/ability to do business.</li> </ul> <p><b>Medium:</b></p> <ul style="list-style-type: none"> <li>▪ Measurable damage to the environment</li> <li>▪ Subject to potential future legislation</li> <li>▪ Potential to affect reputation/cost</li> <li>▪ Implication/reduced efficiency</li> </ul> <p><b>Low:</b></p> <ul style="list-style-type: none"> <li>▪ Negligible damage to the environment No risk to business</li> </ul>

#### 4.2 Important issues and concerns raised during consultation

During consultation it was observed that maximum of people was in favor of project and following issues and concerns were raised. Stakeholder Consultation it is mentioned in detail in

#### Chapter 10.

- During survey following concerns of the local community, Government Departments and Environmental Practitioners and experts were noted:
- Nuisance must be controlled.
- Latest/State of the art technology must be adopted.
- Locals should be preferred for the job opportunities.
- Monitoring should be done regularly to check efficiency.
- Solid waste should be managed effectively by adopting the standard practices of the area.
- Cleanliness of the area should be ensured.
- An effective EMMP should be designed and enforced with true spirit.
- Health of the workers should be ensured.

#### 4.3 Significant impacts and factors to be determined

Main impacts and factors to be determined are:

- Occupational Health and safety
- Site Security
- Traffic Management
- Hygiene management
- Job opportunities for locals
- Resource conservation
- Avoid excessive water consumption
- Energy efficient techniques must be adopted
- Proper site restoration after construction
- Tree plantation at designated green areas
- Emergency preparedness

---

## 5 CONSIDERATION OF ALTERNATIVES

---

This chapter will discuss alternative and their selection and rejection criteria.

### 5.1 Site alternatives (selection and rejection criteria)

For installation of steel industry unit it is important that site must be selected at suitable location.

- Selected site is located in non-negative and non-agricultural area.
- Transportation infrastructure (road network) is available.
- Safe distance from sensitive receptors (residential area & protected area)
- The selected site is under the ownership of the proponent.

### 5.2 Design/technology alternatives (selection and rejection criteria)

The project technology will be up to date and will also environment and eco-friendly. So, no other technology will be taken under consideration.

### 5.3 Environmental alternatives (selection and rejection criteria)

Environmental considerations are of utmost importance in selecting site. There is no sensitivity in the area from environmental setting point of view. Thus there is no ecologically sensitive or declared protected area such as territorial waters, forest, game reserve or biodiversity parks within a 10 km radius of the project site, requiring the proponent to look for site alternatives.

### 5.4 Economic alternatives (selection and rejection criteria)

The technology selected for establishment of project will be economical viable than alternatives present as compared to majority of the other available production technologies but it will be most efficient and convenient to use.

## 6 DESCRIPTION OF PROJECT

This chapter provides the description of "Metal Master Business (Steel Industries), type and category of project, location and layout, vegetation features of site, project schedule of implementation and complete description of proposed project related to its process and steps.

### 6.1 Type & category of project

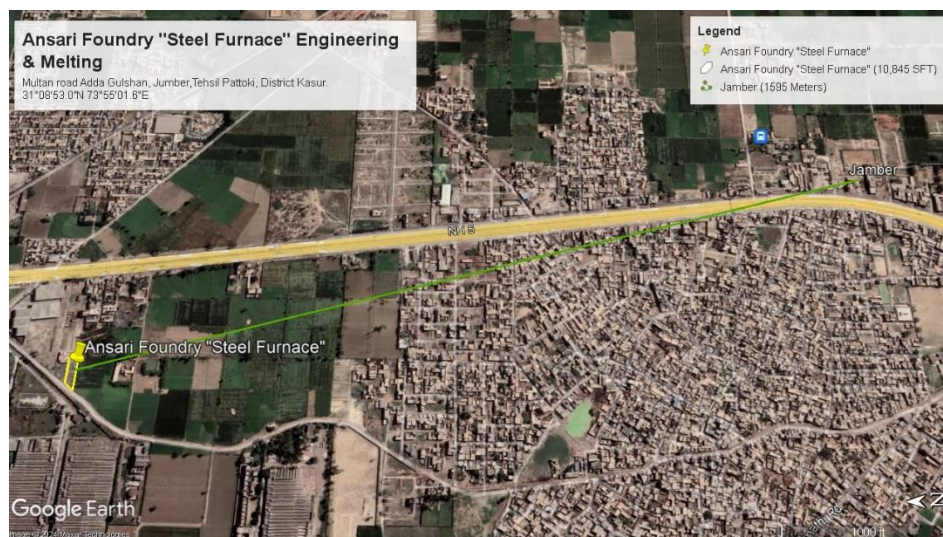
As per Punjab Environmental Protection Act 1997 (amended 2012) and Initial Environmental Examination (IEE) & Environmental Impact Assessment (EIA) Regulations, 2000 proposed project falls under **Category C (2) "Mining and processing of major non-ferrous metals, iron and steel rolling"** mentioned in Schedule-II. Thus, requires an EIA Report is being prepared for duly submission in EPA, Punjab.

### 6.2 Objectives of project

The objective of this project is to make affordable and user-friendly products (auto parts) that everyone can use. To fulfill this, management of project will strive to provide with innovative, competitive and sustainable solutions, and in order to reduce the impacts on environment, while always taking patient needs into account. With technology, proponent will be able to assist customers at any and every stage of the development process to help ensure the product's success.

### 6.3 Location and site layout of project

The project site is located Multan road Adda Gulshan, Jumber, Tehsil Pattoki, District Kasur Google Earth map of site is given in **Fig-1**.

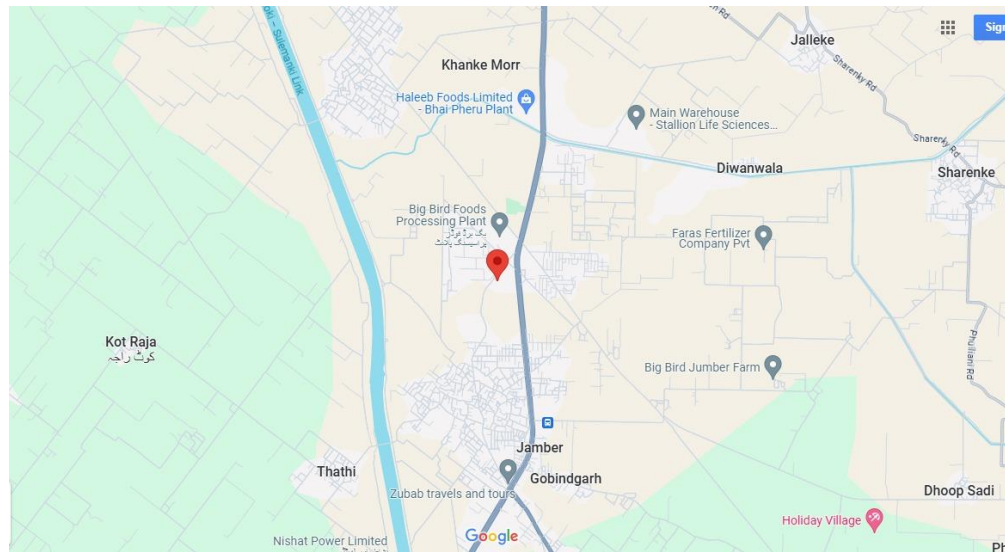


**Figure 1: Location map of site****6.4 Land use on the site**

There is no vegetation present on site. Further, there are no mountains or hills of any kind could be seen in the area.

**6.5 Road access**

The site is accessible through National Highway-5. Access map is given in **Fig-2**

**Figure 2: Road access map****6.6 Vegetation features of the site**

There is no vegetation, as the current project site is a vacant plot. However, proponent will make arrangements to plant trees, building green belts, and garden and plant ornamental plants.

**6.7 Cost and magnitude of operation**

Total cost of the proposed project is estimated to be around **90 million PKR** which includes the provision of installation, associated amenities and cost for utilities and equipment/machinery. Thus, falls under Schedule II for which Environmental Impact Assessment (EIA) report is required. Production capacity of proposed steel furnace foundry will be 100 tons/month.

### 6.8 Schedule of implementation

It is projected that the construction phase of entire project will be started after getting environmental approval from EPA Punjab and complete in the period of 5-6 months. Activities involved are:

- Assessment of environmental impacts and its mitigation measures
- EIA approval, other local issues
- Implementation of recommended alteration in system, if required
- Commencement of operation

### 6.9 Description of the project (process flow chart/steps, technology, raw material and products, by-products)

The project will include installation of Electric Induction Furnaces and Re-Rolling furnace in order to make steel.

#### 6.9.1 Raw materials source, quantifications & list of machineries

**Table 4: Raw materials**

Description of raw material	Source	Quantity
Scrap	Local purchase (imported/scrap yard)	3200 tons/M
Iron Scrap	Local purchase (imported/scrap yard)	3200 tons/M
Storage capacity of yard		100 tons/M

#### 6.9.2 List of machineries to be installed

List of machineries is given in below **Table-5**.

**Table 5: List of machineries**

Sr No.	Description	Quantity
1.	Electric Arc Furnace	01
2.	Power Track	01
3.	Over Head Crain	02

4.	Press Bundle	01
5.	Weight Scale	02
6.	Water Pumps	02
7.	Hydraulic Pump	01

### ***6.9.3 Production process and by-products & technology (Electric Induction Furnace)***

An electric arc furnace will be installed on plant. The production process is follows:

The EAF process has developed as an efficient melting apparatus. The modern designs focus on increased capacity of the furnace. Melting will accomplished by supply of energy to the furnace interior. This energy will be electrical. Electrical energy will be supplied via the graphite electrodes. Initially, an intermediate-voltage tap will be selected until the electrodes dig into the scrap. Light scrap will placed on top of the charge to accelerate bore-in. About 15% of the scrap will be melted during the initial bore-in period. After a few minutes, the electrodes shall penetrate the scrap deep enough to allow for a high-voltage tap that would develop long arc without fear of radiation damage to the roof. The long arc maximizes the heat of the arc as will transfers the power to the scrap and a liquid pool of metal in the hearth of the furnace.

If the initiation of arc creates an erratic and unstable arc, wide swings in current will be observed accompanied by rapid movement of the electrodes. Temperature in the furnace will rise, the arc will be stabilized. When the molten pool will be formed, the arc would become quite stable, and the average power input increase. When enough would be melted to accommodate the second charge, the charging process will be repeated. After the final scrap charge would be melted, the furnace sidewalls will be exposed to intense radiation from the arc. As a result, the voltage will reduce. Alternatively, creation of a foamy slag allows the arc to be buried; this will protect the furnace shell. In addition, a greater amount of energy will be retained in the slag and will be transferred to the bath, resulting in greater energy efficiency. When the final scrap charge will be fully melted, flat bath conditions will be reached. At this point, the bath temperature will be taken, and a sample will be collected. The analysis of the bath chemistry will allow the melter to determine the amount of oxygen to be blown during refining. At this point, the melter can also

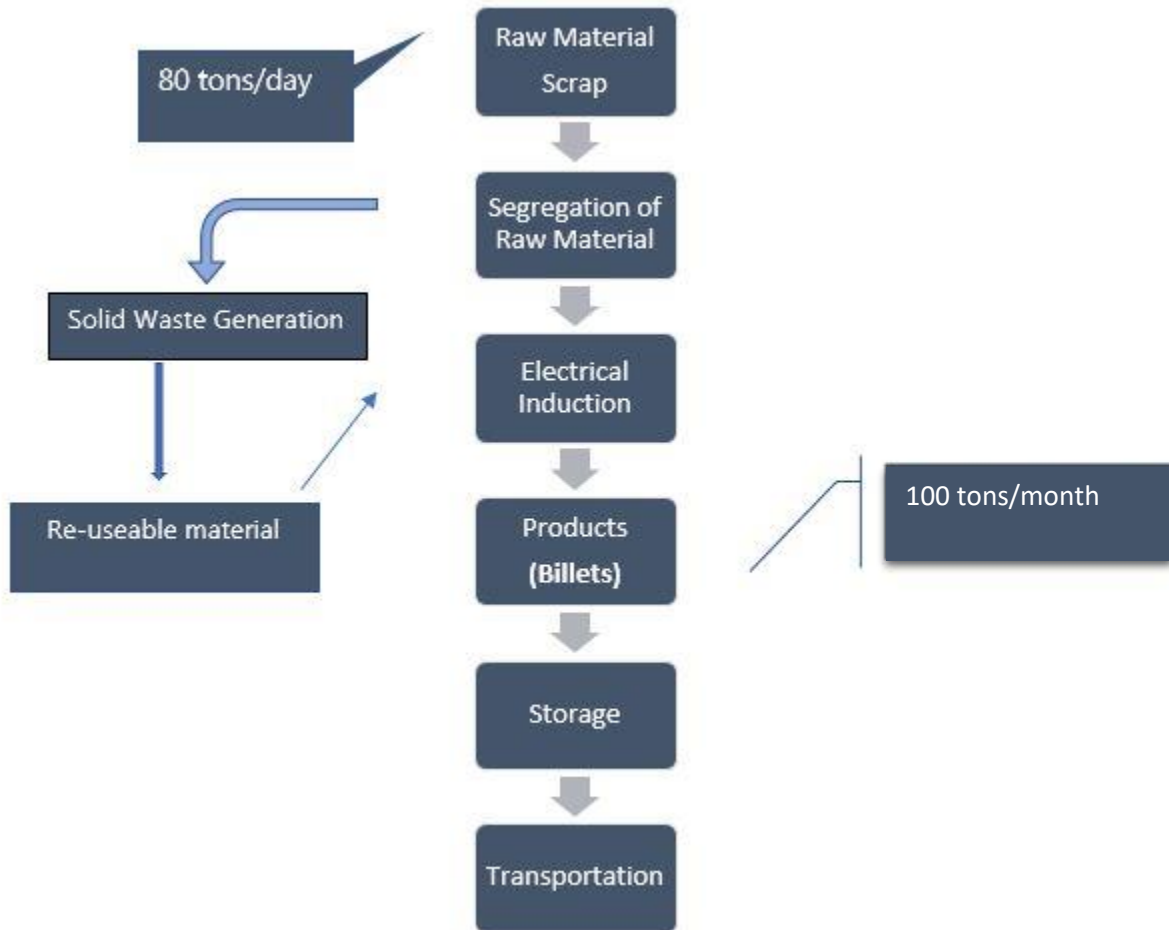
start to arrange for the bulk tap alloy additions to be made. These quantities will be finalized after the refining period.

*a) Products*

The products will be billets.

**6.9.4 Process flow diagrams**

The process flow diagram with is given below in **Fig-3**.



**Figure 3: Process flow diagram**

**6.9.5 Pollution control technologies**

Pollution control technologies will be installed to reduce the pollution load on environment. Below are given pollution control techniques.

#### 6.9.5.1 Emission control

Air emissions will be generated while burning the scrap to convert it into billets. The generated emissions will have high concentration of the PM, CO and CO<sub>2</sub>. These emissions generate a dense cloud of the smoke. To control this, dry scrubber will be installed on chimneys which will reduce up to 95% of emissions. Furthermore, the furnaces will work on electricity and no fuel will be used to gaseous emissions will be negligible. For dust control arising from combustion of raw material will be control via dry scrubbers. Moreover, for surface dust abatement, water showering will be practiced.

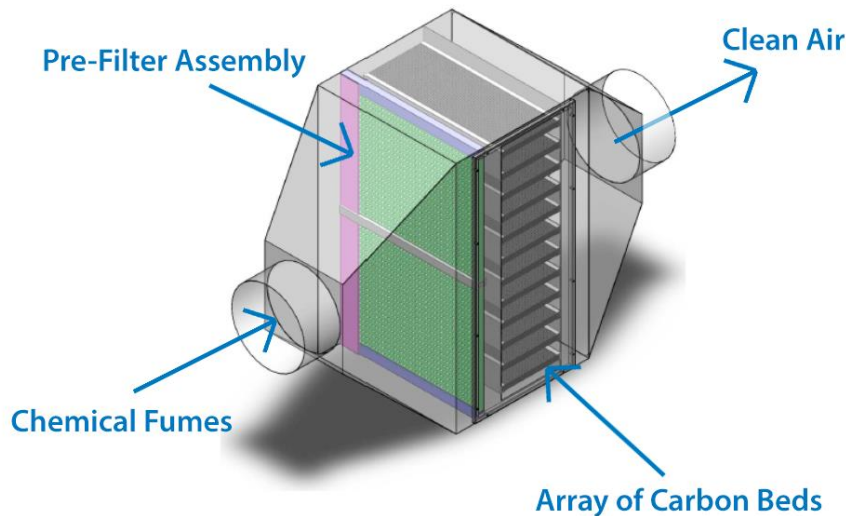
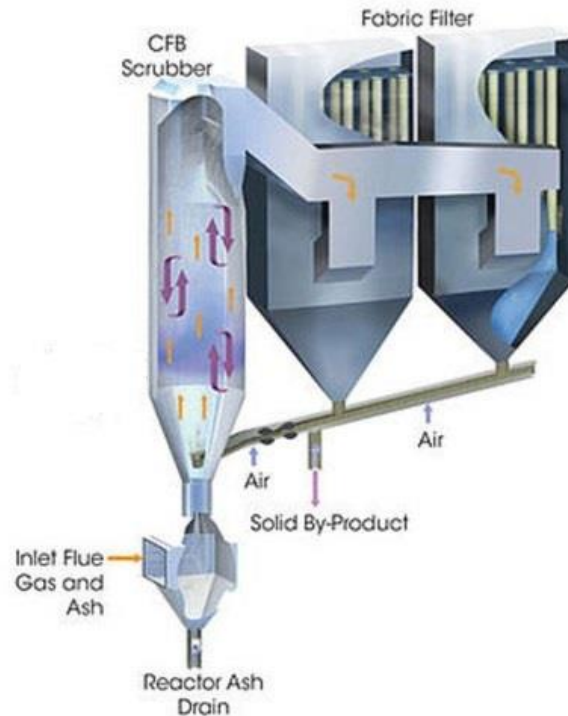


Figure 4: Dry Scrubber working principle



**Figure 5: Dry scrubber preliminary design**

#### 6.9.5.2 Waste water

Only grey water will be produced from kitchen, staff offices and washrooms. This water will be treated in settling tanks prior to disposal.

#### 6.9.5.3 Solid waste

The solid waste will be generated during the cooking in the workers mess. The amount of the solid waste generated will be quite low, which will be disposed off by using sustainable practices. The generated waste will be collected in the bins and at the end of the day it will be dumped in the ground. The generated compost will be used for the horticultural practices at site.

### 6.10 Restoration and rehabilitation plans

There will be no any matter of rehabilitation as the site is already owned by the project proponent. However, at the end of the life of the unit, it will be duly dismantled with special precautions to avoid/minimize pollution and at the same time taking all safety precautions to protect human life and property around the project site. Debris or any other wastes resulting from demolishing will be

disposed-off in environmentally sustainable fashion. The materials capable of recycling/reuse will be either sold in the market or to be reused for other suitable purposes. While dismantling, Government rules and regulations as applicable to such activities will be strictly adhered. Safety measures as desired under the code of demolition will be adopted to avoid any harm to humans, property around, or the environment in the project area. Dust to be generated will be minimized by constant sprinkling of water. After completion; all demolishing matrix, debris and garbage will be removed off immediately from the site within the minimum possible time under safe conditions. Any minor spillover of these materials will be cleared adequately. The land, if and where pitted will be adequately levelled. On the whole, the project site and the area in its near vicinity will be made neat and clean.

#### **6.11 Government approvals**

The environmental approval according to the Section 12 of Punjab Environmental Protection Act is the mandatory requirement of the project.

---

## 7 DESCRIPTION OF ENVIRONMENT

---

This section covenants with the prevailing environmental conditions of the project area. Information that has been collected from different sources, including public literature, reports of other studies conducted in this area, knowledge with the proponent and the concerned government departments and the first-hand surveys and field measurements has been presented in this section. This encompasses all the important aspects of local environment; such as biological resources, socioeconomic development and quality of living values.

### 7.1 Baseline physical environment

This section provides a clear description of the physical resources such as topography, soil, climatic conditions, surface and groundwater resources and quality, ambient air quality and geology of the project site but also city as a whole. The description of physical environment of project site is presented in following subsections.

This section covenants with the prevailing environmental conditions of the project area. Information that has been collected from different sources, including public literature, reports of other studies conducted in this area, knowledge with the proponent and the concerned government departments and the first-hand surveys and field measurements has been presented in this section. This encompasses all the important aspects of local environment; such as biological resources, socioeconomic development and quality of living values.

### 7.2 Methodology

The methodology employed to collect the baseline data and information regarding the social structure and various related parameters as discussed in sub-sections below:

### 7.3 Data collection

The primary data was collected by visiting the project area and its communities in its nearby vicinity. The secondary data regarding physical parameters (topography, geology, seismology, and climate) was obtained by visiting relevant various government departments and their official websites. The biological parameters such as flora and fauna were studied by preparing a floristic list based on visual observation and fauna was studied by using opportunities approach. The species were recorded with reference to their existence in the project area. Information on wildlife

fauna species (mammals, amphibians, reptiles, birds, etc.) in the assessment area was compiled based on opportunistic observation, gathering the existing information and consultation with local experts, community members and government and Non-Government Organizations (NGOs). The socioeconomic aspects were studied and analyzed by studying detailed village profile and by conducting household surveys.

#### **7.4 Social survey**

The purpose of social survey was to record the present condition of the people living in the project area and to assess the expected project impacts on their life, subsistence systems and socio-cultural conditions. Prior to conducting the field surveys, the following steps were taken: Clear boundaries of the project area were identified. Decided the sampling procedure in order to draw a representative sample size of the target population and households Developed the tools for data collection i.e. questionnaires to access the socio-economic status of the area.

#### **7.5 Review of Legal and Administrative Framework**

The objective of reviewing legal and administrative framework is to obtain information on all legislation pertaining project development. The Socio-Environment Team of reviewed the environmental policies, national, international and provincial laws and guidelines relevant to the development of project which helped in systematic identification of impacts.

Baseline conditions refer to the existing physical, environmental and socio-economic status of the project area. On the basis of baseline information, the project interventions are assessed and mitigation measures are proposed. The baseline information also helps to indicate the specific issues to be monitored during construction and operational phases. The baseline data (physical, biological and socio-economic parameters) related to the project area is described below. Information provided is based on primary and secondary data collected by site visits, desk studies and consultation with locals respectively. This section gives the overview of the topology, geology, seismology and meteorological conditions of whole city whereas, it gives detailed information about the surface water, ground water and air quality of the project area.

#### **7.6 Baseline Physical Environment**

This section provides a clear description of the physical resources such as topography, soil, climatic conditions, surface and groundwater resources and quality, ambient air quality and

geology of the project site but also city as a whole. The description of physical environment of project site is presented in following subsections.

## **7.7 Topography**

Kasur District lies between River Satluj which flows along its boundaries with India and River Ravi which flow its boundary with Sheikhpura District. The districts may be divided into two parts, a low lying or riverine area along the two bordering rivers and upland, away from the rivers. The riverine area is generally inundates during monsoon season. The water level in this area is higher than in the upland. The soil of the district is sandy. The upland is flat plains sloping from North-West to South-West. The general height of the area is from 150 to 200 meters above the sea level. The land of the project area is plain and highly fertile i.e. consists of sand silt and clay in equal ratios. The irrigation in most of the areas is through the canal system as well as by using water pumps. The topography of the proposed site is flat.

### **7.7.1 Hydrology**

Groundwater from depth of 100 ft can be used for drinking and other purpose. Groundwater is the major source of water in the study area, which is extracted with the help of pumps and motors. The groundwater extracted is used to fulfill various domestic, irrigation and industrial needs. Ground water quality report of area is annexed. No surface water body is present within 10 km radius of the project site.

### **7.7.2 Seismicity**

According to Seismic Zoning of Pakistan, the project area lies in Zone 2A and represents minor to moderate damage due to earthquakes.

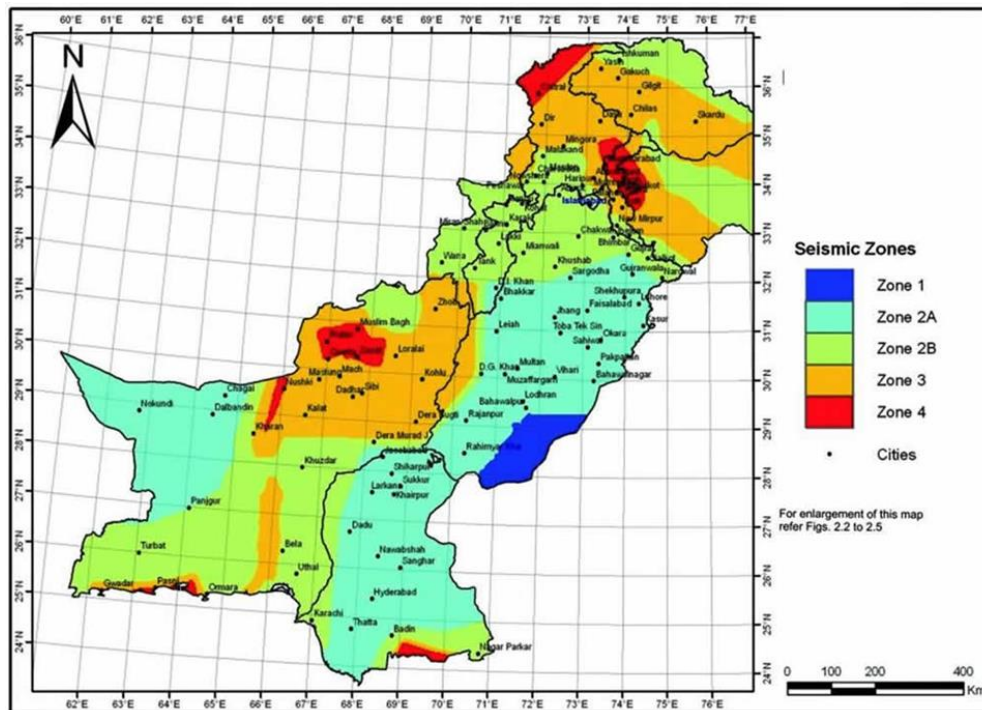
### **7.7.3 Geography**

The District Kasur is bounded by the Ravi River in the North-West and River Sutlej in the South-East whereas, the old course of Beas River bifurcates the district into two equal parts locally known as Hither and Uthar or Mithan Majh. Both of the areas have a height differential of approximately 5.5 meters. The natural surface elevation of the district is 198 meters above the sea level, having a general slope from North-East to South-West whereas, the East and West ends of the district comprise the flood plains of the rivers Satluj and Ravi, characterized by breaching of looping river Channels braided around meander bars.

Kasur District is attached with Lahore from east, attached with Nankana Sahib from North, attached with Faisalabad from West and attached with Okara and India from South. The geographical coordinates of the City are 31° 7'3.40" north and 74°26'59.82" east, whereas, the coordinates of the project site are (31°08'53.0"N 73°55'01.6"E).

### 7.7.4 Climate

Climate of District Kasur is very hot and dry in summer and cool in winter. The hottest months are April to September. The maximum and minimum temperatures are 46°C and 28°C respectively. The coldest months are December to February. During this period the temperature fluctuates between 16°C and 6°C as shown below. Temperature at the project site was 28°C. Precipitation is the lowest in November, with an average of 3 mm. The greatest amount of precipitation occurs in July, with an average of 1150 mm.



**Figure 6: Seismic Zones of Pakistan**

### 7.7.5 Geography

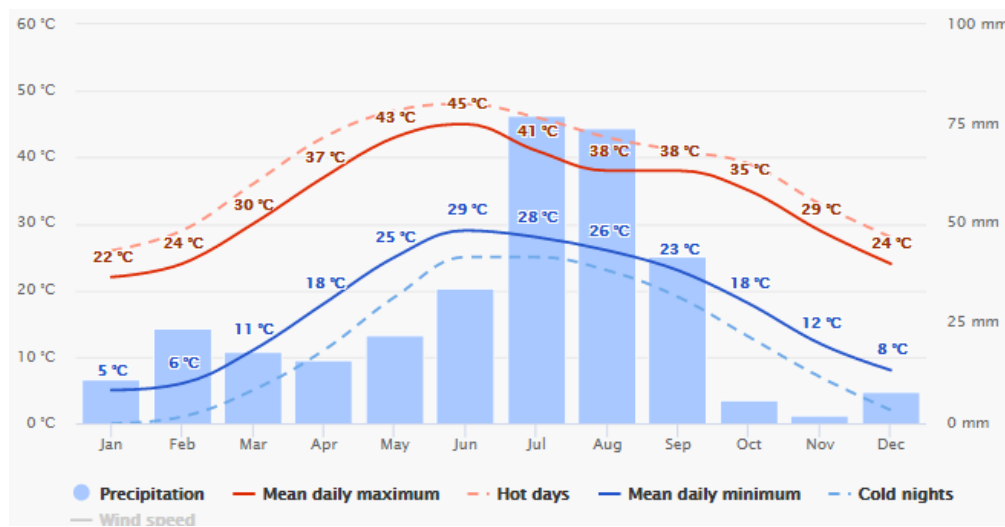
The District Kasur is bounded by the Ravi River in the North-West and River Sutlej in the South-East whereas, the old course of Beas River bifurcates the district into two equal parts locally known

as Hither and Uthar or Mithan Majh. Both of the areas have a height differential of approximately 5.5 meters. The natural surface elevation of the district is 198 meters above the sea level, having a general slope from North-East to South-West whereas, the East and West ends of the district comprise the flood plains of the rivers Satluj and Ravi, characterized by breaching of looping river Channels braided around meander bars.

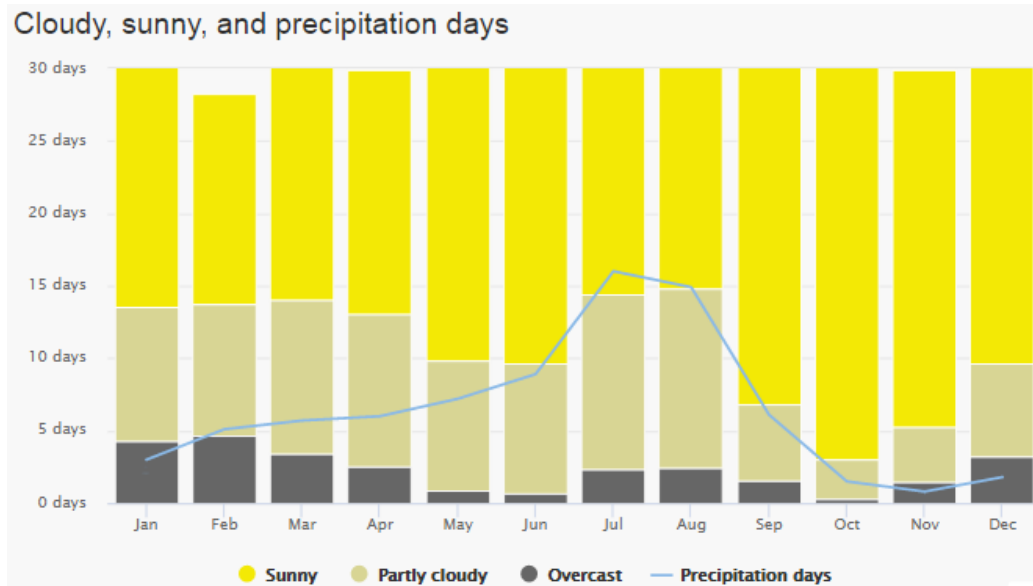
Kasur District is attached with Lahore from east, attached with Nankana Sahib from North, attached with Faisalabad from West and attached with Okara and India from South. The geographical coordinates of the City are 31° 7'3.40" north and 74°26'59.82" east.

### 7.7.6 Climate

Climate of District Kasur is very hot and dry in summer and cool in winter. The hottest months are April to September. The maximum and minimum temperatures are 46°C and 28°C respectively. The coldest months are December to February. During this period the temperature fluctuates between 16°C and 6°C as shown below. Temperature at the project site was 28°C. Precipitation is the lowest in November, with an average of 3 mm. The greatest amount of precipitation occurs in July, with an average of 1150 mm. The "mean daily maximum" (solid red line) shows the maximum temperature of an average day for every month for Kasur. Likewise, "mean daily minimum" (solid blue line) shows the average minimum temperature. Weather in Kasur is influenced by Subtropical Dry Semiarid Steppe climate. Low-latitude dry climate. Evaporation exceeds precipitation on average but is less than potential evaporation.

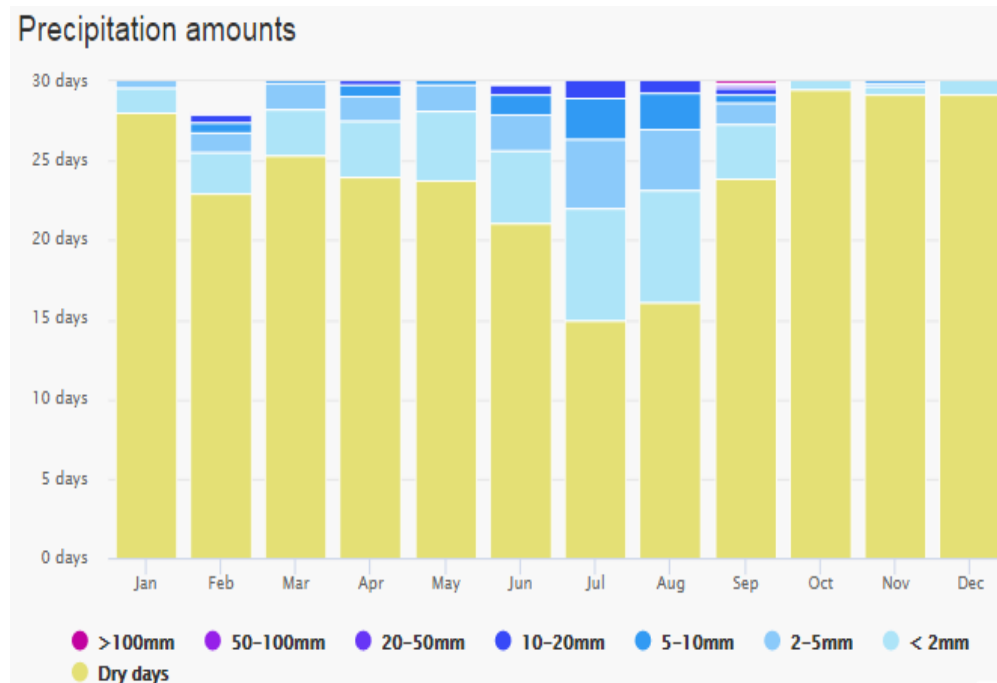


**Figure 7: Average Annual Temperatures and precipitation in Kasur**



**Figure 8: Maximum temperature ranges in Kasur**

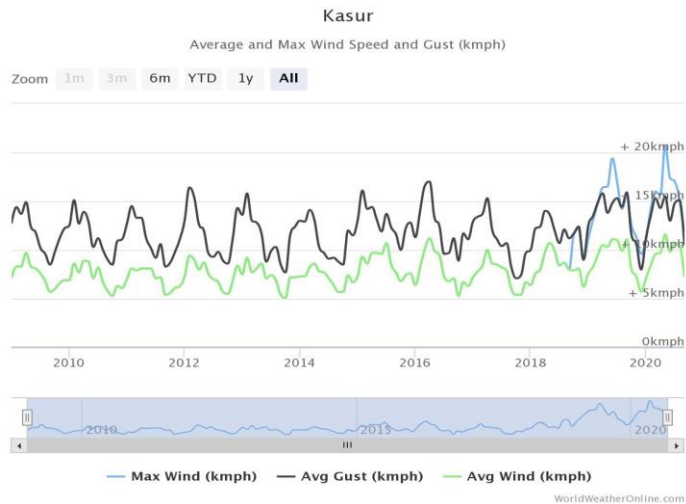
The graph shows the monthly number of sunny, partly cloudy, overcast and precipitation days. Days with less than 20% cloud cover are considered as sunny, with 20-80% cloud cover as partly cloudy and with more than 80% as overcast.



**Figure 9: Annual Precipitation amounts in Kasur**

**7.7.7 Wind**

The diagram for Kasur shows the Max and Average Wind speed and Wind Gust.



**Figure 10: Annual average wind speed in Kasur**

**7.7.8 Ecological Environment**

Kasur is enriched with the presence of natural flora and fauna, although with the growing population and development activities, the presence of some has been somewhat affected. They are discussed in detail below.

**7.7.9 Aquatic Flora & Fauna**

No aquatic ecosystem (i.e. canal, stream, river or pond) observed within or around the study area, which omits the possibility of any kind of aquatic species that may be harmed due to the establishment of proposed project.

**7.7.10 Flora**

The project is located in agricultural area. The project site has no vegetative cover, hence, no trees or vegetation will be removed. The dominant tree species in study area include; Eucalyptus, Neem, and Kikar. The crops present around project site include wheat, sugarcane and common grass. The nomenclature including common, English, local and botanical names of the flora found in the study area are presented in Table.

**Table 6: Flora of the Study Site**

Sr. No.	Common Name	Scientific Name
<b>1</b>	Neem	<i>Azadirachta indica</i>
<b>2</b>	Kikar	<i>Vachellia nilotica</i>
<b>3</b>	Safeda	<i>Eucalyptus globulus</i>

#### 7.7.11 Fauna

For study of fauna in the project area, field guides and books were consulted. On the other hand field observations were conducted along with the interviews of local community members about the fauna of the area. The equipment used in field included cameras, binoculars and GPS device (wherever required). It is important to note that there is a number of factors which can change the findings of such survey. It may be pointed out that the pattern of seasonal migration of small birds varies depending upon each specie. During the construction activity in project area, no important biological feature will be damaged. The fauna commonly found in District Kasur includes; Hares, Falcon, Eagle, Quail, Starling, Jungle Pigeon, Russian Sparrow, Doves, King Fisher, Parrot, Crow and Local Sparrow. Commonly found mammals in the area include; dogs, cats, horses, house-rats, squirrels, porcupines and bats. However, Small Indian Mongoose and Indian Palm Squirrel are also found in the District Kasur.

**Table 7: Mammals in study area**

Common Name	Scientific Name
Rat	<i>Rattus</i>
Bat	<i>Chiroptera</i>
Small Indian Mongoose	<i>Herpestes javanicus</i>
Indian Palm Squirrel	<i>Funambulus palmarum</i>
Porcupines	<i>Erethizon dorsatum</i>

Squirrels	<i>Sciuridae</i>
-----------	------------------

The commonly found bird’s species include; House Sparrow, Crow and some of them are mentioned below with scientific names.

## 7.8 Baseline Socio-Economic Environment

This section provides collective information about the existing socio-economic and environmental condition of the project area within the AOI. The different types of socio-economic aspects were covered such as demographic profile, occupation, education and health facilities. This data helped in identifying major interventions for the development of Environmental Management and Monitoring Plan (EMMP). The study also helped to assess the positive or adverse impacts on local community.

### 7.8.1 Socio-Economic Profile of Study Area

This topic provides an overview of the baseline information relating to the socio-economic environment of the project area and the AOI. The socio-economic study gives information about the demographic profile, occupation, education and health facilities in the project area.

### 7.8.2 Study Area Profile

The village profile reflects the basic socio-economic conditions of local people. These parameters indicate the needs of society while planning the the aforesaid project. The village profile has been obtained by meeting with community representatives who are well aware about their surroundings. The consultant, with his team, visited project area and study area in order to identify the socio-economic and environmental aspects of project. The following information is obtained by surveying the community.

**Table 8: Study Area Profile**

Serial No.	Socio-Economic Indicators	Qutba
1.	Language Spoken	Punjabi
2.	Distance from Project Area	1 km

3.	Accessibility of Road	National Highway-5
4.	Transport	Public and Private Transport
5.	Population	4000+
6.	Livelihood	Agricultural, Livestock and Labor
7.	Houses	More than 200
8.	Educational Facilities	Primary School, Secondary School and Govt. & Private Schools
9.	Institutional Facilities	Mosque
10.	Civil Facilities Available	Electricity, Water Supply and Graveyard
11.	Source of Water	Groundwater
12.	Common Diseases	Fever, Hepatitis, Common Cold, TB, Typhoid, Diarrhea and Malaria
13.	NGO Working in Study Area	NIL
14.	Historical Place	NIL
15.	Simble industries	10
16.	Saw	15
17.	Types of Trees	Neem, Kikkar and Eucalyptus
18.	Disaster Management	NIL
19.	Major problems of the Study Area	Safe Drinking Water, Sanitation and Sewerage System, Roads Access, Educational and Medical Problems
20.	Educational Facilities	Punjabi

### **7.8.3 Demographic Profile**

The Demographic Studies are the major source of any city’s Socio-Economic profile. Demographic Studies relate to population. Population studies are extremely important from Town Planning point of view. Until and unless we know about population in detail, we cannot do successful planning. All aspects of population, such as sex-age composition, trend of migration, social, cultural, political, economic and administrative works, values and facilities have to be related to planning considerations and decisions. Individuals are the raw material of society; therefore, society is directly affected by size, growth, composition and distribution of its individuals. The term population refers to the number of individuals living within a geographical area at a given time.

Different community individuals in the vicinity of the project area have different family sizes depending upon their living setups. Average family size is however 5-7 individuals per family with 1-2 earning hands per family. Since the proposed project is located in an agricultural area, most of the individuals are associated with the agricultural activities.

### **7.8.4 Health Facilities**

Some private health center are present as Villages area present in the vicinity of the project site.

### **7.8.5 Educational Facilities**

As the project site is not located in any residential area. However, the villages located around project site have few government primary schools.

### **7.8.6 Demographic Characteristics of the Population**

The field survey (including interviews, focus group discussions, census, and area profile) was carried out to collect the socioeconomic data from the project affected people as well as other general population to accomplish the baseline information, which will provide the basis for subsequent monitoring and evaluation studies.

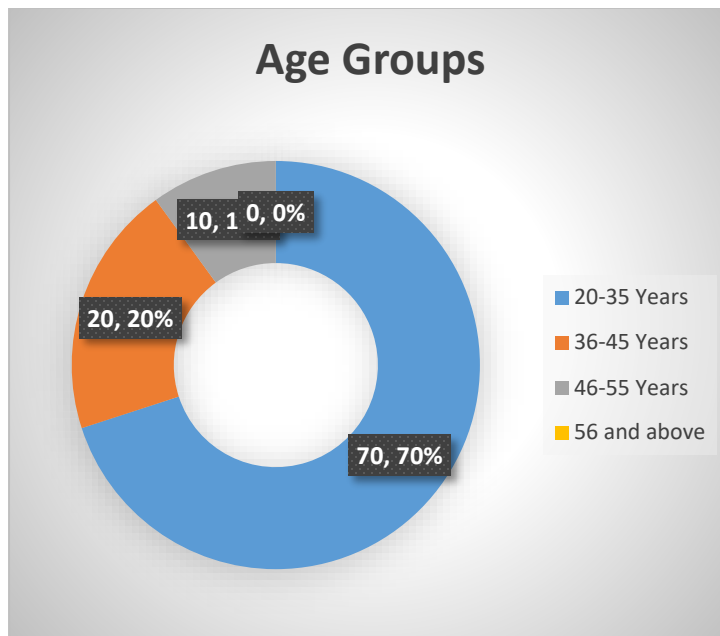
The demographic features include the information on household’s profile, gender composition, occupations, and literacy status of the population residing in the project area. The information relating to the demographic profile of the people in the project area are described below.

### 7.8.7 Family Size

Based on the field survey of local population, the average family size computed to be 5-6.

### 7.8.8 Age Groups

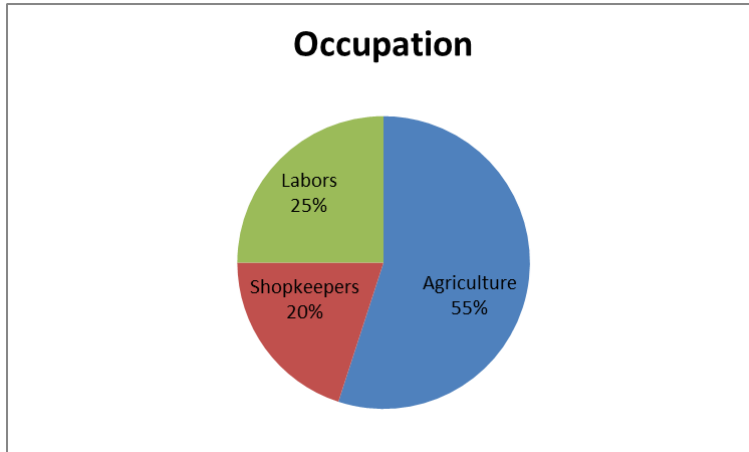
Ages of the consulted population were also recorded. The people interviewed for the socio-economic assessment belongs to different age groups i.e. 20-35 years, 36-45 years, 46-55 years, and 56 years and above.



**Figure 11: Consulted age groups in the area near project site**

### 7.8.9 Occupation of Respondents

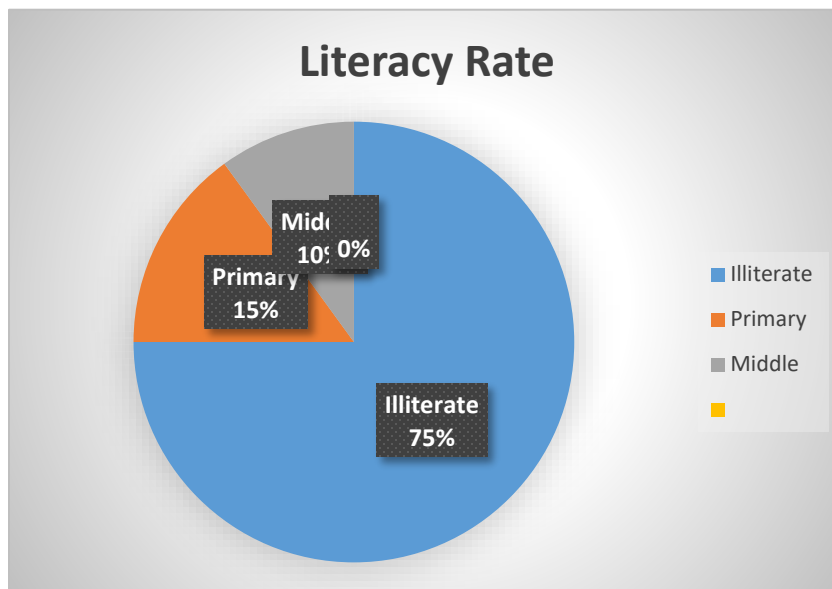
Majority of the respondents (55%) are attached with agriculture, 20% shopkeepers and remaining 15% are labors. During survey, efforts were made to interact with people representing all walks of life. The detailed graphic representation of occupational status is given below:



**Figure 12: Occupation of Respondents**

#### 7.8.10 Literacy Rate

From survey results, it was found that 75 % of the studied population was illiterate, 15% was up to primary level, 10% studied up to middle level.



**Figure 13: Literacy Rate**

#### 7.8.11 Common Diseases

According to the survey the common disease recorded in the project area is Hepatitis.

### **7.8.12 Cultural, Religious & Other Structures**

No cultural, religious and other structures are present in the close proximity of the project area that needs to be relocated. Villages present around the project site have mosques and imam bargah.

### **7.9 Socioeconomic Survey and Public Consultation**

For ascertaining the perceptions of different stakeholders about the project, meetings were held with them. These meetings were held in an open atmosphere, in which participants expressed their views freely. Informal group discussions were also held as an additional tool for the assessment of the perceptions of the stakeholders.

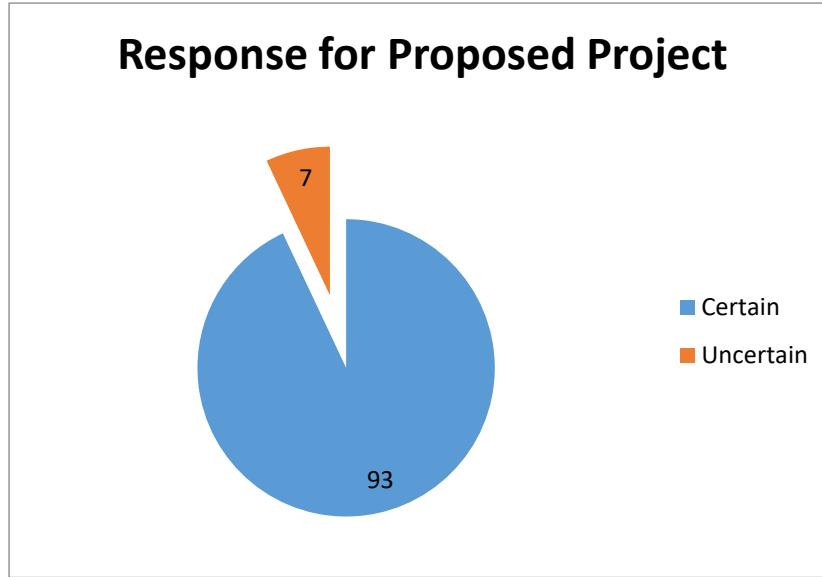
### **7.10 Methods of Public Consultation**

Public Consultation was carried out for a day. The following methods were used for public consultation with project stakeholders in order to ascertain their stakes regarding project implementation.

- Focused Group Discussion
- Scoping Sessions
- Formal Group Meetings
- Informal Group Meetings

### **7.11 Project Response**

93% of the respondents were of the opinion that this project should be implemented. In their opinion, construction of the project will create labor opportunities for locals and it will help to improve economic conditions of area. The respondents also provided the mitigation measures like certified contractor must be hired, proper plantation should be done, proper procedures should be followed etc. They said, if mitigation measures will be implemented they would have no objection.



**Figure 14: Percentage of people in favor or against the project**

### 7.12 Lab Reports

Lab reports are attached with EIA.

### 7.13 Suitability of Site

The site is very suitable for establishment of storage of feed. The Environmental approval may be awarded.

## 8 IMPACT ASSESSMENT

This section discusses the potential environmental impact of proposed project, methodologies for impact identifications and characteristics of impacts including nature, magnitude, extent and location, timing, duration, reversibility, risk. The assessment carried out in this Section is based on potential impacts on overall environmental receptors within the project area.

### 8.1.1 Methodologies for impact identification

The potential impacts due to establishment of steel mill are mostly beneficial. During construction phase, adverse environmental & social impacts are depending on the resources and receptors involved along with other parameters such as; geographical scope (magnitude and extent), temporal scope (duration) and reversibility. It is anticipated that this project will have maximum positive impacts as it is environmentally friendly project to reduce pollution load.

Moreover, the project is expected to result in negative impacts of short-term duration and transient in nature. Having identified and characterized the potential significant impacts during design, construction and operation phase of project an Environmental Impact Severity Matrix & checklist to summarize all the identified impacts as mentioned below in tables.

**Table 9: Impact significance criteria**

Impact	Criteria
<b>No Impact</b>	When the proposed activity will have no impact
<b>Long Term</b>	When the impact is of high intensity with high spread and high duration or of high intensity with medium spread and medium duration
<b>Moderate Term</b>	When the impact is of moderate intensity with high spread and high duration or of high intensity with low/ moderate spread and low duration
<b>Short Term</b>	When the impact is of low intensity but with moderate spread and moderate duration or of moderate intensity
<b>Insignificant</b>	When the impact is of low intensity, low spread and low duration
<b>Adverse</b>	When the impact is of large intensity, spread easily and long-term

---

<b>Beneficial</b>	When the impacts are positive and improve the environmental conditions
-------------------	--

8.1.2 Checklist

**Table 10: Impact matrix checklist for construction phase**

Environmental Sensitivities	Intensity of Impact						Impact Nature		Impact Significance				
	Low Intensity	Moderate Intensity	High Intensity	Local	Moderate	Regional	Beneficial	Adverse	Insignificant	No Impact	Short Term	Moderate	Long Term
<b>Physical Parameters</b>													
<b>Air Quality</b>		<input type="checkbox"/>		<input type="checkbox"/>									
<b>Noise</b>		<input type="checkbox"/>			<input type="checkbox"/>								
<b>Water Quality</b>		<input type="checkbox"/>			<input type="checkbox"/>								
<b>Biological Parameters</b>													
<b>Land Environment</b>													
<b>Flora</b>													
<b>Fauna</b>													
<b>Physical Parameters</b>													
<b>Local Economy</b>	<input type="checkbox"/>												



**Table 11: Impact assessment checklist for operational phase**

Environmental Sensitivities	Intensity of Impact						Impact Nature		Impact Significance				
	Low Intensity	Moderate Intensity	High Intensity	Local	Moderate	Regional	Beneficial	Adverse	Insignificant	No Impact	Short Term	Moderate	Long Term
<b>Physical Parameters</b>													
<b>Noise</b>		☐											
<b>Water Quality</b>													
<b>Odor</b>	☐												
<b>Biological Parameters</b>													
<b>Land Environment</b>													
<b>Flora</b>													
<b>Fauna</b>													
<b>Physical Parameters</b>													
<b>Local Economy</b>													
<b>Social Impacts</b>													

<b>Health &amp; Safety</b>														
----------------------------	--	--	--	--	--	--	--	--	--	--	--	--	--	--

**8.2 Characteristics of impacts (nature, magnitude, extent and location, timing, duration, reversibility and risk)**

The impact characteristics are identified to screen out potentially insignificant environmental and social impacts from potentially significant adverse environmental and social impacts during planning & designing, construction and operational phases of the project. The objective of impact screening process is to assess the significance of issues related to the air, water, noise, soil, transportation, civil work, communication, the hazards and external constraints. The beneficial and adverse impacts of project during planning & designing, construction and operational phases are identified based on their duration, location, frequency, extent, significance and reversibility. The impact of each activity on various environmental parameters is given below:

**Table 12: Impact assessment characteristics**

Sr#	Environmental Component	Impact Characteristics												
		Duration		Location		Frequency		Extent		Significance			Reversibility	
		Long	Short	Direct	Indirect	Cont.	Intermittent	Wide	Local	Large	Moderate	Minor	Rev.	Irrev.
<b>Beneficial Impacts</b>														
1	Employment Opportunity	☐		☐		☐			☐		☐		☐	
2	Solid Waste Management	☐		☐		☐			☐		☐		☐	
3	Land Value	☐			☐	☐			☐			☐		☐

4	Tree Plantation	<input checked="" type="checkbox"/>		<input checked="" type="checkbox"/>		<input checked="" type="checkbox"/>		<input checked="" type="checkbox"/>		<input checked="" type="checkbox"/>		<input checked="" type="checkbox"/>	
5	Wastewater		<input checked="" type="checkbox"/>	<input checked="" type="checkbox"/>		<input checked="" type="checkbox"/>		<input checked="" type="checkbox"/>		<input checked="" type="checkbox"/>		<input checked="" type="checkbox"/>	
<b>Adverse Impacts</b>													
1	Solid Waste	•		•		•		•		•		•	
2	Health and Safety		•		•		•		•		•		•
3	Physical Hazards		•	•		•		•		•		•	•
4	Security Risks		•		•		•		•		•		•

---

## 9 SCREENING OF POTENTIAL ENVIRONMENTAL IMPACTS AND MITIGATION MEASURES

---

This Chapter identifies the potential impacts (positive and adverse) on the physical, biological and socio-economic environment of project area due to proposed project. It also identifies measures that will help to mitigate the adverse environmental and social impacts (if any) and it will enhance positive impacts of the project. Impacts are assessed by analyzing their magnitude and sensitivity, which is a legal requirement.

### 9.1 Impacts associated with project activities

- Environmental Impact - Construction and Operation Activity
- Socioeconomic Impact - Construction and Operation Activity

### 9.2 Project location

There will be no impacts due to project location as the land is owned by project proponent. For the establishment the steel mill an open plot. In the project area or its vicinity no ecologically important area is present. However, no human settlement or infra-structure will be dislocated due to the establishment of project. So, no adverse impact is being envisaged. Hence, there is no need to change the design of project is required.

#### 9.2.1 *Compensation in money terms*

There is no damage envisaged to fauna, flora or any other biological source due to the establishment proposed project. However, agricultural land is being converted to the built-up area. So, no compensation in monetary terms will be needed as the land is owned by the project proponent.

#### 9.2.2 *Replacement/relocation/rehabilitation*

The proposed project is located in open land where there is no sensitive area, population or natural resource is present which could be impacted due to the establishment of project. No replacement, relocation and rehabilitation is requiring for the proposed project establishment. However, at the end of the life of the unit, it will be duly dismantled with special precautions to avoid/minimize pollution and at the same time taking all safety precautions to protect human life and property around the project site. Debris or any other wastes resulting from demolishing will be disposed-

off in environmentally sustainable fashion. The materials capable of recycling/reuse will be either sold in the market or to be reused for other suitable purposes.

### **9.3 Project design**

The proponent has planned to construct the unit on modern lines, meeting international standards, with incorporation of imported technology. The design, if maintained and operated in an environment-friendly manner, is expected to cast positive impact on the environment and will not pose any adverse impact or threat on any component of the environment.

The design of the proposed project will be sustainable and will follow the principles of energy conservation. The design of the main public buildings will follow the green building designs such as; maximum utilization of the sunlight, high roofs to keep the building cool, etc. Moreover, the building will be designed by keeping in consideration all the technical standards to avoid adverse impacts on the environment and society.

### **9.4 Construction phase**

Following impacts could be impacts during constructional phase of project. The proposed project area is located in well-developed smaller scale industrial area and existing built-up area categorized as the commercial/ industrial area (referring to the google earth view). The roads of the area are metaled. During the transportation of the raw-material such as cement, bricks, sand, gravels, etc. The dust clouds may be generated which could impact the local climatic conditions on temporary basis. This impact is considered in-significant because of the metaled road structure.

#### **9.4.1 Mitigation measures**

Impacts of raw materials transportation can be reduced significantly by adopting better management and monitoring practices. Following management and monitoring practices will be adopted to reduce the impacts:

- Proper tuning of vehicles should be done on the regular basis in order to control the air pollution generated by the burning of the fossil fuels in the vehicles
- Restrict excessive transportation of the vehicles as well as the speed of the haulage trucks that shall not exceed the speed limit of 40km/hour
- Careful site planning and managing the transportation routes for the vehicles carrying raw-materials

- Cover the vehicles with tarpaulin carrying sand and loose material
- The wind prone loose material should be covered and sprinkled with water on the regular basis.

#### **9.4.2 Impacts on vegetation**

There are no vegetation present on site so no mitigation measures are required.

#### **9.4.3 Impacts on water sources**

During construction phase, water will be used for the preparation of the raw material, for watering under-construction buildings and consumption by the workers in various domestic activities. It will cause negative impact on underground water resource. The consumption of the water will be high causing minor negative impact on the water resource of the area. The groundwater may get polluted due to the presence/consumption of the chemicals and petroleum products on-site

#### **9.4.4 Mitigation measures for water**

Following mitigation measures will be required for water sources:

- Avoid un-necessary consumption of the water and close the tap when water isn't in use
- Special care will be required to protect the chemicals and petroleum products from spillage and contaminating the ground water sources
- Proper knowledge regarding the watering of the under-construction building should be given to the workers in order to conserve water
- Water efficient equipment and process will be used
- Awareness regarding the water conservation techniques should be carried out
- The wastewater that is being consumed from the use of the labor on-site will be disposed off in the wastewater drains.

#### **9.4.5 Impacts on air quality**

During construction phase, the machinery working on project site may cause air pollution due to release of the pollutants such as; carbon dioxide, methane, NO<sub>x</sub> and SO<sub>x</sub> from the burning of the fossil fuels in the vehicles. Dust may be generated due to the excavation activity and filling activities. No other impact is envisaged that may deteriorate the ambient air quality of the area.

#### *9.4.6 Mitigation measures for ambient air quality*

Following mitigation measures will be adopted to reduce the impact on the air quality:

- Proper tuning of vehicles should be done on the regular basis in order to control the air pollution
- It should be ensured that the high quality fuel is being used in the vehicles that are working on-site
- The material prone to wind should be covered with tarpaulin
- Avoid unnecessary movement of the trucks carrying raw-materials to avoid unnecessary air emissions
- Avoid excavation and filling activity on the windy days
- Impact can be minimized through a management programs which ensure dust will be controlled by regular watering the dusty and wind areas
- Abandoned excess laterite and stone aggregate littered around stock pile areas after construction completed changes the soil structure
- Regular water sprinkling may be done to control the dust generation

#### *9.4.7 Impacts due to noise*

During construction phase, heavy construction machinery will be use. The machines are noisy and can cause a certain degree of nuisance to the nearby residents. The noise levels of machines and vehicles vary widely depending on the type of noise generated and level of activity. Some common impacts of noise nuisance include annoyance, sleep disturbance and interference with communication. Acceptable levels of noise are regarded to be 40 dB (A) during the night and 50 dB (A) during the day. Since construction will take place during the day only the 50 dB (A) level is of importance. As the proposed project is not located in the residential zone so the noise related impacts will cause insignificant impact on the nearby community

#### *9.4.8 Mitigation for noise*

Following mitigation measure will be adopted to reduce the noise;

- The noise related activities should be done during the day time to ensure minimum disturbance to the local community

- Proper tuning of the vehicles should be done on the regular basis, so that the noise level will be reduce up to the acceptable limits
- Noise related activities should be done speedily and completed as soon as practically possible
- Construction activity will be confined to the small reserved area

#### *9.4.9 Impacts on socio-economic environment*

During this phase, skilled and unskilled labor will be required. Employment opportunities for the un-skilled workers will therefore increase which will enhance the positive benefits for the local people who are in dire need of income for sustenance. Furthermore, indirect opportunities for employment will arise from the provision of services to the construction teams; sale of raw-material such as cement, bricks, sand etc., as well as food and beverages for the labor. After completion of construction phase serve as a permanent business opportunity.

#### *9.4.10 Mitigation measures*

No mitigation is required.

### *9.5 Operational phase*

The environmental and socio-economic impacts associated with the operation phase are had been studied in detail. Following is the detailed description:

#### *9.5.1 Water consumption*

The increased withdrawal of surface water for the proposed project may affect the water availability for the other users of the project area. A significant impact will be interpreted, if water extracted for the project directly affects the ability of the community and other users to meet their water needs. The water usage will be the water required for domestic use of workers, for floor cleaning.

#### *9.5.2 Mitigation measures*

Following mitigation measures will be adopted:

- Water conservation program will be initiated to prevent wastage of water
- The management will ensure maximum recycling of washing water, so that overall consumption could be reduced

- Reusing the water for sprinkling purpose after floor cleaning

### *9.5.3 Wastewater*

The building operations will generate wastewater in the form of domestic wastewater. The wastewater can be a potential source of pollution to surface and groundwater resources of the area. Domestic wastewater generated during building operation is estimated to be approximately 1.4m<sup>3</sup>/day. Implementation of the proposed mitigation measures and regular monitoring is not likely to leave any significant impact of the wastewater from the proposed facility.

### *9.5.4 Mitigation measures*

Following mitigation measures will be adopted for effective management of wastewater:

- The grey water will be treated through settling tank which will be recycled to be re-used in irrigation purposes
- Waste segregation measures would be employed to minimize entry of solid waste into the wastewater stream
- Water conservation strategies will be employed to avoid wastage of water
- Periodic sampling and monitoring of key parameters for wastewater effluent into the receiving body (drain or sewerage system) and for this purpose samples will be collected at the discharge point to ensure effective treatment

### *9.5.5 Noise*

Noise cause stressful effect on the ears, nervous system and heart; especially to people exposed to noise above 85 dB (A) for long period of time. Due to the operation of the proposed project heavy machines can serve as the potential noise sources. This noise will depend upon the machine efficiency, their maintenance level and the nature of room housing it, and the atmospheric conditions. No significant increase in noise level in the community is envisaged under normal operation. Moreover, implementation of the below-stated mitigation techniques will also keep the noise impacts at minimum to the workers as well as to the community.

### *9.5.6 Mitigation measures*

Noise management and mitigation plan should follow the underlying strategy:

For people working in noisy installations, ear-protection aids like ear-plugs, ear-muffs, noise helmets, headphones etc. must be provided to reduce occupational exposure. This is possible if working methods are improved by:

- Proper designing and fabrication
- Proper lubrication and better maintenance of machines
- Covering noise-producing machine parts with sound-absorbing materials to check noise production
- Reducing the noise produced from a vibrating machine by vibration damping i.e. making a layer of damping material (rubber, neoprene, cork or plastic) beneath the machine
- Using silencers to control noise from automobiles, ducts, exhausts etc. and convey systems with ends opening into the atmosphere
- Using glass wool or mineral wool covered with a sheet of perforated metal for the purpose of mechanical protection

Noise can also be controlled with barriers by enclosing the source of the noise, by placing sound-reducing barriers between the worker and the source, or by increasing the distance between the worker and the source

- Tree plantation helps to block the propagation of sound. Proponent has planned tree plantation in and around the unit premises
- Sound-proof materials will also be used for construction
- During the project operation, it should be ensured that the noise level does not exceed prescribed limits as set by WHO or Pak-EPA; for which regular monitoring must be carried out.

#### ***9.5.7 Waste management***

Improper disposal of the solid waste generated during the operational phase of proposed project can pose a health hazard; pollute soil, surface and ground water. Proper implementation of the mitigation measures will ensure that the residual impact from improper management and disposal of the waste is minimal. Monitoring and inspection will be undertaken to ensure compliance and minimize any residual impact.

Following mitigation measures will be adopted:

- Waste generation will be minimized by adopting waste management strategy of reduce, reuses and recycle
- A waste management plan will be prepared, implemented and monitored for the safe collection, storage and treatment/disposal of the building waste
- Quantities of waste disposed, recycled, or reused will be logged on a Waste Tracking Register
- Records of all waste generated will be maintained
- Training will be provided to personnel for identification, segregation, and management of waste
- Various waste containers for waste collection should be placed at appropriate locations in the building
- Waste management inspections will be undertaken on a regular basis of onsite waste management and of waste disposal contractors to ensure that the waste management procedures are being followed

Monitoring measures will include:

- Record of all waste generated
- Quantities of waste disposed, reused at site or sold should be logged on the waste tracking register
- Audit of waste management on annual basis
- The areas around the project boundary and access roads should be periodically inspected to verify that no project related waste is scattered in these areas

#### **9.5.8 Air emissions**

The air emissions will release dust and particulate matter in the environment. If these emissions are not handled may damage the health of workers, may be the cause of public nuisances and the wear& tear of the shelling machinery is fast.

#### **9.5.9 Mitigation measures**

Following mitigation measures will be adopted:

- PPEs such as; dust mask will be provided to the workers
- Pre-cleaning and installation of dry scrubber will be carried out to reduce the dust emission
- Water sprinkling will be carried out as and when required

#### *9.5.10 Emergency response*

Incidents and accidents may take place unexpectedly during project operations no matter how effective, strong and efficient the mitigation measures for all adverse impacts; especially the safety issues may be adopted. These may include; fire hazard which may poses a serious threat.

#### *9.5.11 Mitigation measures*

Following mitigation measures will be adopted:

- Fire extinguishers should be properly maintained and checked periodically
- Adequate fire hydrant system should be installed
- Flammable materials should be prohibited in the premises
- Fire alarm systems should be maintained for detection and warning of fire
- Adequate training of workers on use of fire-fighting system to deal with the situation.
- Administration of the unit will make a proper evacuation plans for emergency escape from all halls
- Emergency call service must be made available
- Fire-fighting team must remain ready at all times

#### *9.5.12 Occupational hazards*

It includes occupational hazards like physical injuries arising from accidents such as being hit by falling weak structures, being overrun by heavy equipment. The major safety issues in operational phase are:

- Electrical Hazards
- Machine Guarding
- Eye, Head and Foot Protection
- Fire and Explosion Hazards
- House-Keeping Issues

### 9.5.13 Mitigation measures

Following mitigation measures will be suitable:

- Care will be taken to properly ground and insulate all equipment
- Proper machine guarding, which is critical for the prevention of injuries to workers by isolating them from moving machinery, will be provided
- Head, arms and foot PPE's will be provided
- Fire-fighting equipment will be available and their locations will be clearly marked
- Exits from work places will be well marked and visible in dim light
- Fire water will be located throughout the plant in well-marked piping
- Housekeeping will be frequent and thorough to prevent slips, trips, and falls
- Workers will be told and encouraged to use PPEs as may be standardized
- Workers' awareness and safety wall chart showing safety symbols will be displayed.
- First Aid Box will be kept in easy approach of all in case of any injury or mishap.
- Basic medical and health facilities will be provided to all employees
- Safety and warning devices such as reflectors, lights, etc. shall be installed at designated spots
- Visual monitoring of hazards and accidents will be done in order to control the potential hazard

### 9.6 Potential environmental enhancement measures

Tree plantation within and outside the premises is a potential environmental enhancement measure. A large area will be reserved for tree plantation and among plants native flora like Peepal, Kikar and Amaltas will be planted in the specified green zone which will have the maximum capacity to reduce noise pollution and tolerance index of these species are more than 10. Some floral species like roses and other ornamental evergreen plants will also be introduced in the lawn which will enhance aesthetic beauty. In addition, trees like Amaltas will be planted as boundary wall inside the lawn which will look like green wall. The proponent will also make arrangements for protection and maintenance of trees

### ***9.7 Building enhancement***

The introduction of an ecologically effective and efficient design of a commercial building is the environmental enhancement measures planned by the proponent to be incorporated into the design of the intended project.

#### ***9.7.1 Social enhancement measures***

Following measures will be adopted to improve the socio-economic condition of the area:

#### ***9.7.2 Employment/poverty alleviation***

The employment opportunities in the project area will be increased due to the establishment of project at the proposed location. During establishment un-skilled workers will be required as labors, sanitary workers and sweepers as well as for the skilled workers such as; accounts and managers to run the administration office local community will be considered on the priority basis. In totality, the overall economic conditions of the area will be improved due to the establishment of the proposed project.

#### ***9.7.3 Local economy***

The employment opportunities and/or income sources generated by the project construction and operation will be long term in nature. These will be enhanced once the construction phase is completed. The local economy will experience a slight boom during development and operational period.

---

## 10 ENVIRONMENTAL MANAGEMENT AND MONITORING PROGRAM

---

The potential environmental impacts are identified from the planning stage of proposed project through the Environmental Impact Assessment (EIA) process. The EIA has identified potential impacts that are likely to arise during the project. The EIA has examined in detail both negative and positive impacts at each stage of the project covering both construction and operations phase. To minimize the effects of adverse impacts the EIA has recommended mitigation measures. The proposed mitigation measures have been based on the understanding of the sensitivity and behavior of environmental receptors in the project area, the legislative controls that apply to the project and a review of good industrial practices while operating in similar environments.

For effective implementation and management of the mitigation measures an Environmental Management Plan (EMP) has been prepared. The EMP satisfies the requirement of the Punjab Environmental Protection Department Review of Initial Environmental Examination and Environmental Impact Assessment Regulations, 2000.

The EMP is a tool that serves as to manage environmental impacts and specifically focuses on implementation of mitigation measures in its true sense against likely environmental impacts.

### 10.1 Purpose and objective of the EMP

The primary objectives of the EMP are to:

- Facilitate the implementation of the mitigation measures identified in the EIA.
- Define legislative requirements, guidelines and best practices that apply to the project.
- Define the responsibilities of the project proponent.
- Define a monitoring mechanism and identify monitoring parameters in order to:
  - Ensure the complete implementation of all mitigation measures.
  - Ensure the effectiveness of the mitigation measures.
- Define requirements for environmental monitoring and auditing.
- Provide a mechanism for taking timely action in the face of unanticipated environmental situations.
- Identify training requirements at various levels.

### 10.2 Components of the EMP

The EMP consists of the following:

- Legislation and guidelines
- Organizational structure; roles and responsibilities
- Monitoring/Management plan
- Environmental monitoring
- Communication and documentation
- Change management Plan
- Training program/schedule

### **10.3 Legislation and guidelines**

The EIA has discussed national and international legislation and guidelines that are relevant to the project; proponent will ensure that the project is conducted in conformance to the project proponent corporate environmental policy, national legislation and relevant international conventions and that guidance is sought from national and international guidelines. Project proponent will also ensure that its key project management staff and all its assigned contractors are aware of these legislation and guidelines prior to the start of project activities

### **10.4 Description of proposed mitigation actions**

It lists all the mitigation measures identified in the EIA and the associated environmental or social aspect in line during construction and operational phase with the administrative framework involving all the responsible implementing authorities who are required to take the planned actions/measures and monitor it accordingly. It enhances project benefits by reducing its impacts and making it environmental friendly. The environmental management and monitoring plan is given below in table.

**Table 13: Description of proposed mitigation actions**

Sr. No.	Project Activity	Impacts	Mitigation Measures	Responsibility
1	Water Resources	<ul style="list-style-type: none"> <li>▪ Depletion in groundwater aquifer</li> <li>▪ Water contamination</li> </ul>	<ul style="list-style-type: none"> <li>▪ Water extraction will be kept at minimum and waste management plan will be developed.</li> <li>▪ Wastewater from construction &amp; installation site will be directed to settling tanks.</li> <li>▪ Fuel and chemicals will be stored in covered and with bund walls, underlain with impervious lining.</li> <li>▪ Spill prevention plan shall be followed to mitigate any kind of spill.</li> </ul>	Proponent & Contractor
2	Air Quality	<ul style="list-style-type: none"> <li>▪ Dust emissions during construction activities.</li> <li>▪ Combustion products from vehicles used for project-related activities.</li> </ul>	<ul style="list-style-type: none"> <li>▪ Water will be sprinkled daily on all exposed surfaces to suppress emission of dust.</li> <li>▪ All construction equipment used during the project will be properly tuned and maintained in good working condition.</li> <li>▪ Regular maintenance of project vehicles to ensure that engines are in sound working condition and are not emitting smoke;</li> </ul>	Proponent & Contractor

3	Noise	<ul style="list-style-type: none"> <li>▪ Noise Pollution</li> <li>▪ Disturbance to the site workers</li> <li>▪ Nuisance for surrounding communities and wildlife</li> </ul>	<ul style="list-style-type: none"> <li>▪ Proper maintenance of vehicles and potentially noisy equipment.</li> <li>▪ Minimize/avoid unnecessary use of noisy machinery.</li> <li>▪ Blowing of horn will be prohibited.</li> <li>▪ Provision of Personal Protective Equipment (PPE) to the on-site personnel in high noise areas.</li> </ul>	Proponent & Contractor
4	Solid Waste	<ul style="list-style-type: none"> <li>▪ Surface and groundwater pollution</li> <li>▪ Soil contamination</li> </ul>	<ul style="list-style-type: none"> <li>▪ Recyclable material will be separated at source and will be sold to waste contractor.</li> <li>▪ Hazardous waste will be segregated and stored in closed</li> </ul>	Proponent & Contractor
Sr. No.	Project Activity	Impacts	Mitigation Measures	Responsibility
		<ul style="list-style-type: none"> <li>▪ Air pollution, odor</li> <li>▪ Health hazards</li> <li>▪ Aesthetic issues</li> </ul>	<p>containers in a fenced storage area with paved floor;</p> <ul style="list-style-type: none"> <li>▪ On-site audits of the waste management will be undertaken on a regular basis during the period of project activity.</li> <li>▪ Records of all waste generated during the project activity period will be maintained. Quantities of waste disposed, recycled, or reused will be logged on a waste tracking register.</li> </ul>	

			<ul style="list-style-type: none"> <li>▪ Training will be provided to personnel for identification, segregation, and management of waste.</li> <li>▪ No waste will be dumped at any location.</li> </ul>	
5	Traffic Control	<ul style="list-style-type: none"> <li>▪ Disturbance to local community</li> </ul>	<ul style="list-style-type: none"> <li>▪ Movement of vehicles (trucks) will remain confined to defined access and limited to a specific duration.</li> <li>▪ Regular maintenance of vehicles to reduce exhaust emissions.</li> <li>▪ Parking at NO PARKING areas shall not be allowed.</li> </ul>	Proponent & Contractor
6	Worker’s Health and Safety	<ul style="list-style-type: none"> <li>▪ Health problems or immediate risk may take place.</li> <li>▪ Occupational health of workers and community may be affected.</li> </ul>	<ul style="list-style-type: none"> <li>▪ Compliance to emergency response plan for emergencies and accidents will be ensured to avoid health safety risks.</li> <li>▪ Work safety measures and good workmanship practices are to be followed by the contractor to ensure no health risks for laborers.</li> <li>▪ Protection devices ( earmuffs) will be provided to the workers operating in the vicinity of high noise generating machines.</li> <li>▪ Proper maintenance of facilities for workers will be monitored.</li> <li>▪ Provision of protective clothing for labors e.g. helmet, adequate footwear, protective goggles, gloves</li> </ul>	Proponent & Contractor

			<ul style="list-style-type: none"> <li>▪ Ensure strict use of wearing PPE during work activities.</li> <li>▪ Provision of proper safety signage at sensitive/accident prone spots.</li> </ul>	
7	Socio-Economic/ Local community	<ul style="list-style-type: none"> <li>▪ Community disturbance</li> <li>▪ Community awareness</li> <li>▪ Skilled and un-skilled jobs for local community</li> </ul>	<ul style="list-style-type: none"> <li>▪ All community grievances will be recorded and maintained in a Community Complaint’s Register.</li> <li>▪ Maximum number of unskilled and semi-skilled jobs will be reserved for the local communities.</li> <li>▪ An increase in the income of locals may occur due to employment during project activities.</li> <li>▪ Communities will be informed about the project activities and possible disturbance in advance.</li> </ul>	Proponent & Contractor

**Table 14: Management and Monitoring Plan – Operation**

Sr. No.	Project Activity	Impacts	Mitigation Measures	Responsibility
1	Water Use/ Wastewater	<ul style="list-style-type: none"> <li>▪ Surface water contamination</li> <li>▪ Pollution risk from accidental spillage</li> </ul>	<ul style="list-style-type: none"> <li>▪ Wastewater from the proposed activities will be contained in settling tanks and will be reused.</li> <li>▪ Compliance of effluent with PEQS will be ensured prior to discharge in water body.</li> <li>▪ Water conservation practices will be followed to minimize the water usage.</li> <li>▪ Water use will be monitored periodically to ensure that water is not wasted.</li> <li>▪ In case of any accidental spillage, emergency plan should be implemented.</li> </ul>	Proponent & Contractor
2	Air Emissions	<ul style="list-style-type: none"> <li>▪ Compliance with prescribed PEQS for ambient air</li> </ul>	<ul style="list-style-type: none"> <li>▪ Proper ventilation and exhaust system for air passages;</li> <li>▪ Control of processing exhaust emissions by proper maintenance of production unit/equipment;</li> <li>▪ Proper maintenance of machinery is required to control emissions;</li> <li>▪ Daily maintenance of transport vehicles is required to control air emissions.</li> </ul>	Proponent & Contractor

3	Noise	<ul style="list-style-type: none"> <li>▪ Noise Pollution</li> <li>▪ Disturbance to the personnel handling the installations</li> </ul>	<ul style="list-style-type: none"> <li>▪ The noise generating area at the operations will be lined with boundary wall to reduce impact on the workers.</li> <li>▪ Operators of proposed developments will wear ear protections while operating or working nearby high noise emission sources.</li> <li>▪ Tree plantation to reduce the effect of noise pollution.</li> </ul>	Proponent & Contractor
			<ul style="list-style-type: none"> <li>▪ The proposed project will be placed such that the cumulative noise levels at walkways and worker locations will not exceed PEQS for noise.</li> </ul>	
4	Waste Management	<p>If not managed properly;</p> <ul style="list-style-type: none"> <li>▪ Surface and groundwater pollution</li> <li>▪ Soil contamination</li> <li>▪ Air pollution, odor</li> <li>▪ Health hazards</li> <li>▪ Aesthetic issues</li> </ul>	<p>Solid waste management plan will be implemented and following mitigation measures will be taken:</p> <ul style="list-style-type: none"> <li>▪ Only municipal solid waste will be produced which will be segregated and disposed off using environment friendly techniques</li> <li>▪ Area supervisor will mark the quantity/weight and nature of the material on the drums and logbook.</li> <li>▪ Training will be provided to personnel for identification, segregation, and management of waste.</li> </ul>	Proponent & Contractor

5	Occupational Health and Safety	<ul style="list-style-type: none"> <li>▪ Health problems or immediate risk may take place.</li> <li>▪ Occupational health of workers and community may be affected.</li> </ul>	<ul style="list-style-type: none"> <li>▪ Providing basic medical training, safety training to work staff and basic medical service during operations.</li> <li>▪ Firefighting equipment, safe storage of hazardous material, first aid, security, fencing, and contingency measures in case of accidents.</li> <li>▪ Provision of adequate sanitation, washing, cooking and dormitory facilities including light up to satisfaction;</li> <li>▪ Adequate signage, safety cones, lightning devices, barriers, yellow tape and persons with flags.</li> <li>▪ Adequate signage, safety cones, lightning devices, barriers, yellow tape and persons with flags during operations.</li> </ul>	Proponent & Contractor
---	--------------------------------	--	---	------------------------

## 10.5 Schedule of implementation and environmental budget

### 10.5.1 Schedule of implementation

This project will be completed in 05-06 months after getting Environmental Approval. The total cost of the project is **PKR 90 million approx.** which includes; the cost of civil work, purchase of machinery and its installation, implementation of mitigation measures, site rehabilitation, etc.

### 10.5.2 Environmental budget

Environmental budget will be allocated for protection of environment. PKR 1.0 million will be allocated as environmental budget in both constructional and operational phase of project.

**Table 15: Cost breakup of environmental budget**

Constructional Phase		
Serial No.	Activity	Environmental Budget
1.	Air Quality Monitoring/Emission monitoring	Pkr/- 200,000
2.	Noise Monition	Pkr/- 50,000
3.	Waste Water Monitoring	Pkr/- 200,000
4.	Fire Safety	Pkr/- 200,000
5.	PPE's	Pkr/- 50,000
6.	Potential Environment Enhancement Measures	Pkr/- 200,000
Total		<b>Pkr/- 100,000,0</b>
Operational Phase		
Serial No.	Activity	Environmental Budget
1.	Air Quality Monitoring/Emission monitoring	Pkr/- 200,000
2.	Noise Monition	Pkr/- 50,000
3.	Waste Water Monitoring	Pkr/- 200,000

4.	Fire Safety	Pkr/- 200,000
5.	PPE’s	Pkr/- 50,000
6.	Potential Environment Enhancement Measures	Pkr/- 200,000
Total		Pkr/- 100,000,0

### 10.6 Environmental management team along with their roles and responsibilities

Proponent shall hire environmental management team in operational phase of project. The roles and responsibilities of environmental management team are given below in table.

**Table 16: Roles & responsibilities of environmental management team**

Roles and Responsibilities		
Sr#	Concerned Persons	Duties
1	The Project Manager	<p>Following will be the responsibilities of the Project Proponent:</p> <ul style="list-style-type: none"> <li>▪ Ensure that the contractor is aware of all specifications, legal constraints, standards and procedures pertaining to the project specifically with regards to environment.</li> <li>▪ Ensure that all stipulations within the EMMP are communicated and adhered to by contractor(s)</li> <li>▪ Monitor the implementation of the EMMP throughout the project by means of site inspections and meetings. This will be documented as part of the minutes of the site meeting documents</li> <li>▪ Ensuring project execution within defined budget and timelines</li> </ul>

		<ul style="list-style-type: none"> <li>▪ Conducting regular check of the project status and meetings with project team</li> <li>▪ Provide support and guidance to project team as and when needed</li> <li>▪ Project proponent is expected to continually monitor and improve the overall performance of their operation</li> </ul>
4	HSE Manager	<p>In addition to the health and safety responsibilities held by staff, managers and supervisors must do whatever is reasonably practical to ensure that both the workplace and the work itself are safe. This includes:</p> <ul style="list-style-type: none"> <li>▪ Ensuring that staff are appropriately trained and supervised</li> <li>▪ Identifying, assessing and managing health and safety risks</li> <li>▪ Consulting with workers (including staff, affiliates and contractors</li> <li>▪ Health and safety risk assessments</li> <li>▪ Decisions are made about the measures to be taken to eliminate or control these risks</li> <li>▪ Health and safety risk assessments</li> <li>▪ Implementing health and safety risk management programs relevant to their operations, teaching, research and consulting functions and work environment</li> <li>▪ Reporting investigating and responding to all hazards, accidents, incidents and taking action to control the risk</li> <li>▪ Assisting with the development, implementation and maintenance of a return to work program for injured staff.</li> <li>▪ Be fully conversant with the EIA and conditions of its approval</li> <li>▪ Be fully conversant with the EMMP</li> </ul>

		<ul style="list-style-type: none"> <li>▪ Be fully conversant with all relevant environmental legislation, policies and procedures, and ensure compliance</li> <li>▪ Convey the contents of this document to the contractor site staff and discuss the contents in detail with the Project Manager and Contractor             <ul style="list-style-type: none"> <li>▪ Undertake regular and comprehensive inspection of the site and surrounding areas in order to monitor compliance with the EMMP</li> <li>▪ Take appropriate action if the specifications contained in the EMMP are not followed</li> <li>▪ Monitor and verify that environmental impacts are kept to a minimum, as far as possible</li> <li>▪ Review and approve construction methods, with input from the Site Manager, where necessary</li> <li>▪ Ensure that activities on site comply with all relevant environmental legislation</li> <li>▪ Compile progress reports on regular basis, with input from the Site Manager, for submission to the Project Manager, including a final post excavation audit</li> <li>▪ Liaise with the Site Manager regarding the monitoring of the site</li> <li>▪ Report any non-compliance or remedial measures that need to be applied</li> <li>▪ All environmental problems arising on the construction area will be reported to the Site Manager by the Environmental Manager. Reports on such problems will be submitted to the Project Manager by the Site Manager</li> </ul> </li> </ul>
--	--	--

### 10.7 Proposed monitoring program to assess performance or output of EMP

For effective monitoring, management and documentation of the environmental performance during the construction and operational phase of the project, environmental matters will be discussed during meetings held on-site. Environmental concerns raised during the meetings will be mitigated after discussions between project proponent and the contractors. Any issues that require attention of project proponent higher management will communicate to them for action. Project proponent and its contractors will ensure that the communication and documentation requirements specified in the EMP are fulfilled during the project.

Environmental monitoring can be categorized into two types; 1) compliance monitoring and 2) effects monitoring. The environmental monitoring program is summarized in **Table 21** which identify the roles and responsibilities of project monitoring, further described in detail in following section

### 10.8 Compliance monitoring

Compliance monitoring will be carried out to ensure compliance with the requirements of the EIA. The objectives of the EIA compliance monitoring will be to:

- Systematically observe the activities undertaken by the contractors or any other person associated with the project.
- Verify that the activities are undertaken in compliance with the EIA and other conditions identified by project proponent.
- Document and communicate the observations to the concerned person(s) of project proponent so that any corrective measures, if required, can be taken timely.
- Maintain a record of all incidents of environmental significance and related actions and corrective measures.

Compliance monitoring will be the responsibility of all teams involved in the project activities i.e. project proponent and the contractors. Project proponent staff and contractors will carry out the inspections on a set frequency.

### 10.9 Effects monitoring

To monitor actual impacts of the project on selected sensitive receptors so that impacts not anticipated in the EIA or impacts which exceed the levels anticipated in the EIA can be identified

and appropriate mitigation measures can be adopted in time. This objective will be achieved through effects monitoring.

Considering the environmental conditions of the project area and the assessment of potential impacts of the project made in the EIA, the following environmental parameters will be monitored at identified locations.

**Air Quality Monitoring** – Air quality monitoring will be done during the construction and operation phase of the project at the representative locations. Ambient air quality parameters will include NO<sub>x</sub>, SO<sub>x</sub>, CO, PM<sub>10</sub>, and Smoke.

**Water Quality Monitoring** – Ground and surface water quality monitoring will be done during the construction and operation phase of the project at the representative locations.

**Groundwater Quality Parameters:** Total Coliforms, Total Colonial Count, E-Coli, pH, TDS, Total Hardness, Nitrate, Chloride, Fluoride, Colour, Manganese, Aluminium, Chromium, Cadmium, Boron, Barium, Antimony, Arsenic, Cyanide, Mercury, Nickel.

**Wastewater Quality Parameters:** pH, DO, TSS, Alkalinity, BOD5, COD, Turbidity.

**Noise Monitoring** - The monitoring will be carried out at key locations covering all receptors

**Table 17: Environmental monitoring plan**

Component	Parameters	Monitoring Frequency		Responsibility	
		Construction	Operation	Construction	Operation
Ambient Air Quality	SOx , NOx, CO, PM10, Smoke	Quarterly	As per EPA, Punjab Guidelines	Project Contractor	Proponent
Ground Water Quality	pH, TDS, Chloride, Fluoride, Color, NO3 <sup>-</sup> , Selenium, Residual chlorine, Lead, Total hardness, Turbidity, Zinc, Manganese, Aluminum, Chromium, Cadmium, Boron, Barium, Antimony, Arsenic, Cyanide, Mercury, Nickel, Total Coliform, E.coli, Total count.	Monthly	As per EPA, Punjab Guidelines	Project Contractor	Proponent
Surface & Waste Water Quality	pH, DO, TSS, Alkalinity, BOD5, COD, Turbidity.	Quarterly	As per EPA, Punjab Guidelines	Project Contractor	Proponent
Noise Level	Using noise level meter (minimum dB and maximum dB)	Quarterly	As per EPA, Punjab Guidelines	Project Contractor	Proponent

Occupational Health & Safety	Proper provision of PPEs to workers	Daily	Daily	Project Contractor	Proponent
---------------------------------	-------------------------------------	-------	-------	-----------------------	-----------

### **10.10 Proposed EMP reporting and reviewing procedures**

During construction, EMP reporting and reviewing will be done by the contractor/HSE department. Regular monitoring will be done and reports will be submitted in EPA as per condition of Environmental Approval of construction phase.

- Monitoring reports will be reviewed by EMP team and HSE department
- Photographic records will also be maintained
- Recorded data will be reviewed by supervisory contractor/proponent so that it can be further improved if required.

### ***10.11 Training needs***

Environmental training will help to ensure that the requirements of the EIA and EMP are clearly understood and followed by all project personnel throughout the project period. Environmental training will form part of the environmental management system. The training will be directed towards all personnel for general environmental awareness

### ***10.12 Objectives of the training program***

The key objective of training program is to ensure that the requirements of the EMP are clearly understood and followed throughout the project. The trainings to the staff will help in communicating environmental related controls specified in the EIA and EMP.

### ***10.13 Objectives of the training program***

The key objective of training program is to ensure that the requirements of the EMP are clearly understood and followed throughout the project. The trainings to the staff will help in communicating environmental related controls specified in the EIA and EMP.

### ***10.14 Training schedule***

The training modules will include air, noise and water pollution monitoring, social awareness, Environmental Laws, Environmental Quality Standards usage of personal protection equipment, and health and safety related issues on the construction site.

The contractor will train all construction workers in basic sanitation and health care issues and in general health and safety matters, and on the specific hazards of their work. Training should also consist of basic hazard awareness, site specific hazards, safe work practices, and emergency procedures for fire, evacuation. A generic scope of the training which covers the requirements of

the EIA and the EMP is discussed below in **Table 18** while site contractor will prepare site specific training plan considering these training contents.

**Table 18: Training needs**

Target Audience	Contents	Schedule
Selected management staff of contractor and selected staff	<ul style="list-style-type: none"> <li>▪ Introduction to project EIA and EMP. Key findings of EIA</li> <li>▪ Mitigation measures</li> <li>▪ EMP</li> <li>▪ Social and cultural values of the area.</li> </ul>	Prior to the start of project activities
All site personnel (including locally hired staff)	<ul style="list-style-type: none"> <li>▪ Environmental sensitivity of the project area</li> <li>▪ Waste disposal</li> <li>▪ Community issues/ Social and cultural values</li> </ul>	Prior to the start of project activities
Construction supervisor/ Installation crew	<ul style="list-style-type: none"> <li>▪ EMP communication, documentation and monitoring requirements.</li> <li>▪ Good construction &amp; installation practices.</li> <li>▪ Dust emissions control</li> </ul>	Prior to the start of construction & installation activities
Drivers	<ul style="list-style-type: none"> <li>▪ Safety provision</li> <li>▪ Road access restrictions</li> <li>▪ Dust reduction</li> <li>▪ Waste disposal</li> <li>▪ Emergency response preparedness</li> </ul>	Before and during field operations

Selected staff	Safety provision Hazardous waste disposal Emergency response preparedness	Prior to start of project operations
----------------	---	--

---

## 11 PUBLIC CONSULTATION

---

Public consultation refers to the process by which the concerns of local affected persons and others who have plausible stake in impacts assessment of the project or activity are ascertained with a view to taking into account all the material concerns in the project or activity design as appropriate. According to the IEE and EIA Review Regulations, 2000 public consultation is mandatory for any socio-environmental study. For this purpose, assessment survey and public consultation sessions held with different stakeholder groups that may be impacted. The consultation process was carried out in accordance with the guidelines laid by EPA, Punjab. The objectives of this process were to:

- Share information with stakeholders on proposed project installation and operation.
- To assess the impacts on the physical, biological, and socio-economic environment.
- Understand stakeholder concerns regarding various aspects of the project.
- Understand the perceptions, assessment of social impacts and concerns of the communities of the project area.
- Find out the awareness level and situation of acceptability to identify any issues for the implementation of said project.
- To invite people to express their views about the positive/negative impacts on their life styles and environment.

This report includes all the comments, which were taken into account in preparing the definitive development concept for the installation of the proposed unit.

### *11.1.1 Consultation mechanism*

Primary stakeholders were consulted during informal and formal meetings. The consultation process was carried out in the Urdu language. During these meetings a simple, non-technical, description of the project was given, with an overview of the project’s likely human and environmental impact. This was followed by an open discussion allowing participants to voice their concerns and opinions. In addition to providing communities with information on the proposed project, their feedback was documented during the primary stakeholder consultation. The issues and suggestions raised were recorded in field notes for analysis, and interpretation.

By reaching out to a wider segment of the population and using various communication tools such as participatory needs assessment, community consultation meetings, focus group discussions, in-depth interviews, and participatory rural appraisal EIA involved the community in active decision-making. This process will continue even after this EIA has been submitted, as well as during future EIA in which similar tools will be used to create consensus among stakeholders on specific environmental and social issues.

Secondary stakeholder consultations were more formal as they involved government representatives and local organizations, consulted during face-to-face meetings. They were briefed on the EIA process, the project design, and the potential negative and positive impact of the project on the area’s environment and communities. It was important not to raise community expectations unnecessarily or unrealistically during the stakeholder consultation meetings in order to avoid undue conflict with community’s leaders or local administrators. The issues recorded in the consultation process were examined, validated, and addressed in the EIA report. This section involves communication of possible impacts and concerns with

- Proponents Environmental Management Team
- The responsible authority
- Other departments and agencies
- Environmental Practitioners and experts
- Affected and wider community

### ***11.2 Proponent’s environmental management team***

Consultation regarding establishment of Ansari Foundry “Steel Furnace” Engineering and Melting was done with stakeholders and anticipated impacts were discussed. Concerns of locals, Environmental Practitioners & experts and Government departments were discussed and asked to consider them while construction of above-said project. Locals will be preferred for employment after providing proper training. Mitigations measures mentioned in EMP will be truly implemented.

**11.3 The responsible authority**

Overall responsibility for implementation of EMP will be that of project proponent. He will appoint an HSE/Project Manager of relevant qualification. HSE/Project Manager will act as Environmental Manager and will manage the all HSE condition at the PEQS.

**11.4 The other departments and agencies**

Different Government departments were consulted regarding establishment of proposed project. Government officer were consulted by the socio-environmental team of the consultants and concerned details about the project were noted down through personal interviews, group meetings, etc., in their offices.

**11.5 Environmental practitioners and experts**

Consultation with Environmental Practitioners and experts was done and following comments and suggestions were observed.

**Table 19: Consultation with environmental practitioners and experts**

Name	Qualification	Comments/suggestions
Dr. Sabiha Khurram	Ph.D. Environmental Sciences	Following comments are summarized: <ul style="list-style-type: none"> <li>▪ Latest technology must be preferred</li> <li>▪ Regular monitoring should be conducted</li> </ul>
Ms. Nusrat Ehsan	Ph.D. (scholar) Environmental Sciences	<ul style="list-style-type: none"> <li>▪ She said that current project must be installed as :</li> <li>▪ Quality steel will be available</li> <li>▪ Import cost will be reduced</li> <li>▪ Good household practices must be practiced</li> </ul>
Mr. Danial Zaib	BS Environmental Sciences	He said that:

		<ul style="list-style-type: none"> <li>▪ Locals should be preferred for employment.</li> <li>▪ In case of outsider’s residence must be provided</li> <li>▪ Proper mitigation measures must be adopted while construction and operation of this project</li> </ul>
--	--	---

### 11.6 Affected and wider community

Social survey was conducted to consult with local community. Their concerns were noticed and discussed with proponent and their team. Majority was in favor of project their details are given below in table.

Sr No.	Interviewer’s Name	CNIC NO	The Survey in The Study Area Following Concerns of The Local Community Were Noted: <ul style="list-style-type: none"> <li>▪ Wastewater Should Be Properly Treated Prior To Final Disposal In Nearby Drain.</li> <li>▪ Solid Waste Should Be Managed Effectively By Adopting The Standard Practices Of The Area.</li> <li>▪ Cleanliness Of The Area Should Be Ensured.</li> <li>▪ An Effective EMMP Should Be Designed</li> </ul>
1.	Tauqir Ahmad	35102-1196822-9	
2.	Asif Hussain	37201-3926979-7	
3.	Muhammad Zartash Mehmood	35102-7090303-3	
4.	Muhammad Shafique Faizi	35102-0658502-5	
5.	Ghulam Rasool	35102-6203513-7	
6.	Major Tariq Masood Malik	38201-5302625-9	
7.	Shoaib Ajmal	35102-5036063-3	
8.	Nadeem Rahmat	35201-2020932-7	
9.	Rafaqat Yousaf	35201-2036750-9	
10.	Shahzada Rais	35102-7852125-1	
11.	M Adnan	35102-0596865-9	

12.	Talha Madni	35102-0991597-1	<p>And Enforced With True Spirit.</p> <ul style="list-style-type: none"> <li>▪ Health Of The Workers Should Be Ensured.</li> <li>▪ Plantation Should Be Carried Out At Extensive Scale.</li> <li>▪ Construction Activity Should Be Carried Out During Day Hours.</li> <li>▪ Noisy Activities Should Be Confined.</li> <li>▪ Workers Should Be Hired From Local Community.</li> <li>▪ PPE’S Must Be Provided To Workers</li> <li>▪ Indigenous Trees Around The Facility Should Be Planted To Control Air Pollution.</li> <li>▪ Safeeda Can Be Planted In the Project Area As The Area In Known To Be Affected By The Logging And Salinity.</li> <li>▪ Removal Of Shrubs And Bushes Should Be</li> </ul>
13.	Syed Izhar Hussain Shah	35301-1942149-5	
14.	M Suleman	13504-2245523-9	
15.	Arshad Mehmood	33100-0259837-3	
16.	Ghulam Mustafa	35301-1840812-3	
17.	Sabir Ali	35301-3923044-9	
18.	Walayat Ali	35303-6527575-9	
19.	Hasnain Ajmal	35102-5864223-9	
20.	Asad Bin Abdul Subhan	35202-7449277-7	
21.	Shakeel Subhani	35201-6543975-3	
22.	Kareem Niazi	34204-6536792-5	
23.	Subhan Ali	35102-7627958-4	
24.	Shahbaz Ahmad	35402-7698241-6	
25.	Muhammad Shahid	35202-7359206-1	

			Avoided To The Extent Possible.
--	--	--	---------------------------------

---

## 12 CONCLUSION AND RECOMMENDATION

---

Ansari Foundry “Steel Furnace” Engineering and Melting respects the environment, supports sustainable development and is committed to environmentally sound business practices. The proposed project will provide affordable and high-quality steel auto parts to consumers. This study was carried out to assess the environmental and socioeconomic impacts of the proposed project. The assessment was carried out in keeping with the legislation of Pakistan, as well as national and international guidelines.

Baseline environmental and socioeconomic information was collected from a variety of sources, including reports of previous studies, published literature, and field surveys. The information collected was used to compose profiles of the natural, socioeconomic, and cultural environment likely to be affected by the project.

The proposed activities were reviewed, and an assessment was made of the potential impacts of these activities on the area’s natural and socioeconomic environments, using both qualitative and quantitative assessment methods. Where appropriate, mitigation measures were recommended to keep the environmental impacts within acceptable limits.

It was analyzed that most of the aspects related with the proposed project have very minor impacts. It is therefore concluded that if the implementation of all mitigation measures is carried out as described in this report, the anticipated impact of the project on the area’s natural and socioeconomic environment will be well within acceptable limits.

Proponent of subject project has expressed strong commitment to protection of the social and natural environment from any potential adverse impact of the project. A preventive maintenance philosophy supported by robust inspection plans and sound operational practices will be adopted to ensure sustainable and sound functioning of the proposed project. Therefore, it is recommended that the competent authority may please be issues Environmental Approval for the operation of this project.

---

## 13 APPENDICES

---

### 13.1 Glossary

<b>Air Quality</b>	Measurement of the pollutants in the air; a description of healthiness and safety of the atmosphere.
<b>Consultation</b>	Consultation refers to two-way transfer of information or joint discussion between project staff and the affected population. Systematic consultation implies a sustained and rigorous sharing of ideas. Bank experience shows that consultation often yields the best resettlement alternatives, fruitful procedures for continued participation, and independent information on actual conditions for implementation.
<b>Closure</b>	The action of making new or secret information known.
<b>Env. Management</b>	Attempt to control human impact on and interaction with the environment in order to preserve natural resources
<b>Effluent</b>	Wastewater - treated or untreated - that flows out of a treatment plant, sewer, or industrial outfall. Generally, refers to wastes discharged into surface waters.
<b>Evaluation</b>	The making of a judgment about the amount, number, or value of something; assessment.
<b>Geology</b>	A science that studies rocks, layers of soil, etc., in order to learn about the history of the Earth and its life.
<b>Ground Water</b>	Aquifers currently being used as a source of drinking water or those capable of supplying a public water system. They have a total dissolved solid content of 10,000 milligrams per liter or less and are not "exempted aquifers."
<b>Hazardous</b>	Substance or material, which could adversely affect the safety of the public, handlers or carriers during transportation.
<b>Household</b>	People residing under one roof, using the same hearth and operating as a single economic unit.

---

<b>Impact</b>	Effect on someone or something
<b>Jurisdiction</b>	The extent of the power to make legal decisions and judgments.
<b>Land Acquisition</b>	The process whereby a person is compelled by a public agency to cede all or part of the land a person owns or possesses, to the ownership and possession of that agency, for public purpose in return for compensation  Supervising activities in progress to ensure they are on-course and on schedule in meeting the objectives and performance targets.
<b>Occupational Health</b>	Maintenance of the highest degree of physical, mental and social wellbeing of workers in all occupations by preventing departures from health, controlling risks and the adaptation of work to people, and people to their jobs.
<b>pH</b>	pH is a measure of how acidic/basic water is.
<b>Project Area</b>	The area specified by the funding and/or implementing agency according to the Official Gazette Notification and includes the areas within the administrative limits of the Federal or a Provincial Government.
<b>Proponent</b>	A person who advocates a theory, proposal, or course of action.
<b>Capacity</b>	The volume of products or services that can be produced by an enterprise using current resources.
<b>Quality Control</b>	A system of maintaining standards in manufactured products by testing a sample of the output against the specification.
<b>Rehabilitation</b>	Include all compensatory measures to re-establish; at least lost incomes, livelihoods, living and social systems. It does not include the payment of compensation for required assets.
<b>Scope</b>	The extent of the area or subject matter that something deals with or to which it is relevant.
<b>Social Environment</b>	It includes the culture that the individual was educated or lives in,

---

and the people and institutions with whom they interact.

**Stakeholders**

Include affected persons and communities, proponents, private and public businesses, NGOs, host communities and EPA.

**Topography**

Details of the surface features of land. It includes the mountains, hills, creeks, and other bumps and lumps on a particular hunk of earth.

---

## 13.2 LIST OF ABBREVIATIONS

---

EIA	Environmental Impact Assessment
EMMP	Environment Mitigation and Monitoring Plan
EMP	Environmental Management Plan
EPAs	Environmental Protection Agencies
PEPC	Pakistan Environmental Protection Council
NEP	National Environmental Policy
IEE	Initial Environmental Examination
NGO’s	Non–Government Organizations
NOC	No Objection Certificate
O&M	Operation and Maintenance
PEPA	Pakistan Environmental Protection Act 1997
PEQS	Punjab Environmental Quality Standards
CBD	Convention on Biological Diversity
CITES	Convention on International Trade in Endangered Species
IUCN	International Union for Conservation of Nature
UNDP	United Nations Development Programme
DO	District Officer
PKR	Pak Rupees
hr	Hour
mg/l	Milligram per Liter
mg/m <sup>3</sup>	Milligram per Cubic Meter
PPE	Personal Protective Equipment
QC	Quality Control

SEO	Site Environment Officer
SH&E	Safety Health & Environment
APHA	American Public Health Association
BOD	Biochemical Oxygen Demand
COD	Chemical Oxygen Demand
SPM	Suspended Particulate Matter
SMART	Self-Monitoring and Reporting Tool
NOX	Oxides of Nitrogen
SOX	Oxides of Sulphur
NCS	National Conservation Strategy
PM	Particulate Matter

### 13.3 LIST OF INDIVIDUALS AND ORGANIZATIONS CONSULTED ALONG WITH THEIR WRITTEN FEEDBACK

Sr No.	Interviewer’s Name	CNIC NO	The Survey in The Study Area Following Concerns of The Local Community Were Noted:
1.	Tauqir Ahmad	35102-1196822-9	<ul style="list-style-type: none"> <li>▪ Wastewater Should Be Properly Treated Prior To Final Disposal In Nearby Drain.</li> <li>▪ Solid Waste Should Be Managed Effectively By Adopting The Standard Practices Of The Area.</li> <li>▪ Cleanliness Of The Area Should Be Ensured.</li> <li>▪ An Effective EMMP Should Be Designed And Enforced With True Spirit.</li> <li>▪ Health Of The Workers Should Be Ensured.</li> <li>▪ Plantation Should Be Carried Out At Extensive Scale.</li> </ul>
2.	Asif Hussain	37201-3926979-7	
3.	Muhammad Zartash Mehmood	35102-7090303-3	
4.	Muhammad Shafique Faizi	35102-0658502-5	
5.	Ghulam Rasool	35102-6203513-7	
6.	Major Tariq Masood Malik	38201-5302625-9	
7.	Shoaib Ajmal	35102-5036063-3	
8.	Nadeem Rahmat	35201-2020932-7	
9.	Rafaqat Yousaf	35201-2036750-9	
10.	Shahzada Rais	35102-7852125-1	
11.	M Adnan	35102-0596865-9	
12.	Talha Madni	35102-0991597-1	
13.	Syed Izhar Hussain Shah	35301-1942149-5	
14.	M Suleman	13504-2245523-9	
15.	Arshad Mehmood	33100-0259837-3	
16.	Ghulam Mustafa	35301-1840812-3	
17.	Sabir Ali	35301-3923044-9	

18.	Walayat Ali	35303-6527575-9	<ul style="list-style-type: none"> <li>▪ Construction Activity Should Be Carried Out During Day Hours.</li> <li>▪ Noisy Activities Should Be Confined.</li> <li>▪ Workers Should Be Hired From Local Community.</li> <li>▪ PPE’S Must Be Provided To Workers</li> <li>▪ Indigenous Trees Around The Facility Should Be Planted To Control Air Pollution.</li> <li>▪ Safeeda Can Be Planted In The Project Area As The Area In Known To Be Affected By The Logging And Salinity.</li> <li>▪ Removal Of Shrubs And Bushes Should Be Avoided To The Extent Possible.</li> </ul>
19.	Hasnain Ajmal	35102-5864223-9	
20.	Asad Bin Abdul Subhan	35202-7449277-7	
21.	Shakeel Subhani	35201-6543975-3	
22.	Kareem Niazi	34204-6536792-5	
23.	Subhan Ali	35102-7627958-4	
24.	Shahbaz Ahmad	35402-7698241-6	
25.	Muhammad Shahid	35202-7359206-1	

#### **13.4 SOURCES OF DATA AND FULL LIST OF ALL REFERENCE MATERIAL USED**

---

Data was collected by:

- Field visits
- Published articles
- Stakeholder’s consultation
- Client meetings’

### 13.5 TERMS OF REFERENCES

---

The consultants is required to carry out an environmental impact assessment study of the project under Section-12 of Pakistan Environmental Protection Act 1997/ Punjab Environmental Protection (Amendment) Act 2012.

The Study should be comprehensive and should cover all aspects which are envisaged under the relevant national and provincial laws & regulations including but not limited to:

- Identification and recommendation for suitable solution/treatment/mitigation measures for emissions and effluents such as wastewater and sludge etc. in accordance with Punjab Environmental Quality Standards (PEQS).
- Identification and recommendation for suitable solution/treatment/mitigation measures of solvents, oils (tar), hazardous waste, organic compounds, steam, flue gases, particulate matter and chemical compounds harmful for the environment and other substances leading to air, noise, water and soil pollution in accordance with PEQS.

The Study should be acceptable to the relevant national and/or provincial authorities (relevant authorities) in Punjab.

**13.6 LIST OF NAME, QUALIFICATION AND ROLES OF TEAM MEMBERS  
CARRYING OUT IN IEE/EIA STUDY**

Sr.No.	Name	Designation	Role and Responsibility
1.	Dr. Mateen Shafqat	Peer Reviewer	Technical Peer Review
2.	Mr. Kamal Ahmed Cheema	Lead Environmentalist	Technical Peer review
3.	Ms. Maham Ayesha	Manager Operations	Legal framework review and Stakeholder consultation IEE/EIA Expert, Environmental & Social Baseline, Report Writing.
4.	Huda Ashfaq	Environmentalist	Project Coordination and management, Impact Assessment and Mitigation Measures, Environmental Management Plan, Technical Report Writing.
5.	Mr. Jawad Shafiqe	Zooligist	Legal framework review and Stakeholder consultation, IEE/EIA Expert, Environmental & Social Baseline, Report Writing.
6.	Ms. Amna Hafeez	Environmentalist & GIS Expert	Legal framework review and Stakeholder consultation, IEE/EIA Expert, Environmental & Social Baseline, Report Writing.  Project GIS Mapping
7.	Ms. Rahma Butt	GIS Expert	Legal framework review and Stakeholder consultation, IEE/EIA

			Expert, Environmental & Social Baseline, Report Writing.
--	--	--	---

### 13.7 APPROVALS FROM OTHER CONCERNED DEPARTMENT

---

Attached