

EXECUTIVE SUMMARY

The pharmaceutical industry discovers, develops, produces, and markets drugs or pharmaceutical drugs for use as medications to be administered (or self-administered) to patients, with the aim to cure them, vaccinate them, or alleviate the symptoms. Pharmaceutical companies may deal in generic or brand medications and medical devices. They are subject to a variety of laws and regulations that govern the patenting, testing, safety, efficacy and marketing of drugs. In this regard, M/S World Biz Pharmchem (Private) Limited. is aiming to construct a pharmaceutical products manufacturing plant at Plot No 84-D, Quaid-E-Azam Business Park, Sheikhpura. Proposed project involves production facilities of pharmaceuticals products which are Active Pharmaceuticals Ingredients (API) For medicines. Production and other facilities will be added,

M/s World Biz Pharmchem (Private) Limited at Plot No 84-D, Quaid-E-Azam Business Park, Sheikhpura are planning to construct a pharmaceutical unit under the title of World Biz Pharmchem (Private) Limited (Pvt.) Ltd. The project site/unit is situated at an Industrial land.

According to section-12 of PEPA-1997 (Amended, 2012) Environmental Approval/NOC is a mandatory provision.

The said Environmental Impact Assessment Study will cover the sections-12 for Environmental Approval Punjab Environmental Protection Act, Amended 2012. Furthermore, the study provides relevant information, as required under the officially approved format, to help the decision makers i.e. EPA Punjab before issuing the Environmental Approval.

The main objectives of this Environmental Impact Assessment (EIA) Report are to identify the baseline environmental, biophysical and socio-economic conditions, to examine project alternatives including alternate sites, and to study the potential impacts along with formulation of suitable mitigation measures for an environment friendly implementation of the proposed project site and around the project area.

Table 1: Salient Features of the Project

1.	Project Title	World Biz Pharmchem (Private) Limited
2.	Project Location	Plot No 84-D, Quaid-E-Azam Business Park, Sheikhpura. .
3.	Proponent R/O CINC	Arshad Ali S/O Muhammad Hussain House No.656, Block C, Mumtazabad, Multan. 36302-6210553-1
4.	Consultant	EnvironTech Consultants Private Limited
5.	Total Area	25,636 SFT
6.	Total covered area	16,436 SFT
7.	Capacity of Project	300 Ton/Month 10 Ton/day
8.	Location of project	31°44'13.5"N 74°02'37.7"E

9.	Nature of Area	Industrial
10.	Present status of Land Use	Open/Vacant plot
11.	Land use in the surroundings of project site. North South East West	The project is located in industrial estate. The surroundings are: Road Open/Vacant Land Road Open/Vacant Land
12.	Cost of Project	PKR 88.72 million PKR
13.	Raw material	Liquid Solvent, Solids for Reaction and Gases
14.	Product	Pharmaceutical Products (API for medicines)
15.	Purpose of proposed project	Manufacturing of pharmaceutical products
16.	Nearby emergency services i.e. Hospital, police station, rescue, fire brigade etc.	Akhtar Memorial Hospital (6.2 Km) Rescue 1122 (6.2 Km). Police Station (5.6 Km)
17.	Tree Planation	At Designated Green Areas
18.	Water Source	Ground Water
19.	Status of Project	Open/Vacant Land
20.	Source of Power	WAPDA (LESCO)

1.0 Project Description

The said project is basically a part of healthcare sector that deals with medications, it will be a pharmaceuticals industry namely World Biz Pharmchem (Private) Limited (Pvt.) Ltd. at Plot No 84-D, Quaid-E-Azam Business Park, Sheikhpura, where Active Pharmaceutical Ingredients (API) for medicines will be Produced.

The salient features of proposed unit are as under:

- Imported latest art of technology plant/machinery which incorporates the requirements of PEQS rather the plant based on International Standards which are more stringent as compared to standards of Punjab.
- Active Pharmaceutical Ingredients (API) Section
- Quality Assurance / Quality Control Department:
- Research & Development Department:
- Air Handling System:
- Ware House:
- Personnel:
- Standard Operating Procedures:
- Effluent Treatment:

- Standard Operating Procedure
- Central fire hydrant system, fire alarm systems, Smoke detectors, fire extinguishers are placed.
- Emergency assembling points are mentioned in the factory and the workers are trained to cope with any emergency situation.
- Ornamental plants/trees are grown up, grassy lawns have been developed at open place.
- The stand by generators will be latest art of technology and well-tuned within time. Silencer and sound proof canopies are also installed.

Impacts and Recommended Mitigation Measures

In order to identify all the impacts associated with the project during construction and operational activity with potential to cause adverse environmental impacts, a thorough review has been conducted. Although, there is very low chances of any adverse impact occurrence on the surrounding environment. However, in case of impact arises from the project activity possible necessary measures will be adopted to control the same. Overall the project has positive social impacts specifically on the local population and generally contributes in Pakistan’s GDP. The project may have some adverse environmental impacts of minor to moderate magnitude which will be controlled through mitigation measures proposed in Environmental Management and Monitoring Plan (EMMP). Moreover, there is no tree present on site, few patches of bushes and grass are present, and restoration and reclamation will be carried out by the plantation of native species in specified green areas. Environmental impacts have been identified and mitigation measures are recommended within the Project Area of Influence. The major impacts on physical, biological and social environments are described as under:

Table 2: Impact Summary

Environmental Parameters	Impact Assessment during Different Phases	
	Construction	Operational
A: Physical		
Land Resources		
Soil Erosion and Contamination	-2p	0
Transportation	-1t	-1t
Solid Waste and By-Products	-2t	-2p
Land Use	-2p	NA
Air Resources		
Noise Pollution	-1t	-1t
Air Emission	-1t	-1t
Dust	-1t	-1t
Odor	NA	-2t

Water Resources		
Ground Water	-1p	-1p
Surface Water	NA	NA
Wastewater	-1p	-2p
B: Ecological		
Flora		
Tree Cutting	-1p	+1p
Fauna		
Terrestrial Fauna	-1p	+1p
C: Socio-Economic		
Employment Opportunities	+1t	+1p
Land Value Appreciation	+1t	+2t
D: Hazards		
Biological Hazards	NA	NA
Physical Hazards	-1t	-1p
Chemical Hazards	0	-1p
Health and Safety	-1t	-1p
<i>Legends: 1= Low; 2= Medium; 3= High; 4= Extremely High; NA= Not Applicable; t= Temporary; p= Permanent; app= Applicable; 0= Negligible</i>		

2.0 Environmental and Social Monitoring Plan

Environmental Management and Monitoring Plan (EMMP) were developed for effective implementation of the recommended mitigation measures. The EMMP includes check and balance to control and minimize the identified impacts and monitoring programs to oversee residual impacts, if any, during the operational phase. The EMMP describes procedures to be followed throughout the construction and operation of the project. It also identifies the roles and responsibilities of all concerned personnel, including the persons reporting during the different project phases. Mitigations for physical, biological and socio-economic parameters will be measured to determine compliance with standards established in EMMP. The Monitoring Plan will record the inputs provided by various participants in the environmental and social management process. It will also check whether the prescribed national and provincial guidelines and plans are being followed and that the required mitigation measures and activities are being accomplished in time.

3.0 Monitoring Plans

During operational phase, monitoring is required to be carried out at least once in a month during rainy season to check the soil contamination and surface water level/condition. Moreover, periodic monitoring

should also be carried out regarding ambient air quality, noise and dust level and worker safety. A detailed site monitoring plan has been developed and given in Chapter-7 of this EIA Report.

4.0 Conclusion

The findings of EIA Report showed that although the pharmaceutical manufacturing unit is expected to have significant minor to moderate negative impacts on the environment during the construction and operational phases, but the severity of these adverse impacts can be reduced significantly by adopting EMMP with true spirit as proposed in the Chapter 7 of this EIA Report. The impacts were assessed by frequent site visits, studying related projects and by reviewing the documents. Generally, the project is planned to follow efficient environmental management systems. Specific environmental and social benefits have been mentioned below which depend on the proper application of mitigation measures suggested in EMMP and best engineering practices.

5.0 Recommendations

The intensity and severity of impacts occurred due to the processing varies with change in the nature and magnitude of the project as well as depends upon the baseline environmental conditions of the area. The mitigation measures will require constant information flow and consultation with the stakeholders to ensure the least adverse social-economic impact to outweigh the “no project development” scenario.

- ⊙ The adverse environmental impacts can be reduced significantly by adopting best management and monitoring practices as well as by implementation EMMP with true spirit
- ⊙ Proper PPEs including gloves, face masks, head gear etc. will be provided
- ⊙ No compromise on public health and environment should be allowed
- ⊙ Waste minimization practices should be introduced to workers by conducting lectures on spot to aware the workers about the long-term benefits of the same in lieu of surrounding environment
- ⊙ A proper tree plantation plan should also be developed in order to make the process environment friendly
- ⊙ Small domestic waste storage bins should be placed at different locations for proper collection and disposal of the solid waste
- ⊙ It is recommended that the Proponent should obtain an Environmental Approval (NOC) from the Punjab-EPA before proceeding further.

Contents

EXECUTIVE SUMMARY	1
1. INTRODUCTION	13
1.1 Project Background	13
1.2 Project Nature and Size	13
1.2 Project Location	13
1.4 Regulatory Compliance	14
1.5 The Proponent	15
1.6 Scope of Project	15
1.7 Details of Consultant	16
1.8 Purpose of Report	16
2. SCREENING AND SCOPING	17
2.1 Screening/Type and Category of Project	17
2.2 Scoping:	17
2.3 Alternatives	18
Site Alternatives	18
Project Alternatives	19
Environmental Alternatives:	19
Economic Alternatives:	19
3. DESCRIPTION OF PROJECT	20
3.1 Objectives of Project	20
3.2 Location and Layout of Project	20
3.3 Land Use on Site:	21
3.4 Road Access	21
3.5 Vegetative Features	21
3.6 Amenities	21
3.6.1 Electricity	21
3.6.2 Ground Water Resource	21
3.7 Management Plans	21
3.7.1 Air Emissions	21
3.7.2 Wastewater Management and Disposal	23
3.7.3 Waste Management	23
3.8 Staff/Manpower	24

3.9	Emergency Preparedness	24
3.9.1	Safety Trainings.....	24
3.9.2	24
3.9.3	24
3.10	Cost and Magnitude of Operation	25
3.11	Land ownership Documents	25
3.12	Schedule of implementation	25
3.13	Process Description.....	26
3.13.1	Basic Raw Materials Required by the Proposed Unit	26
3.14	Finished Products	26
3.14.1	Manufacturing Process for Liquid Base Products	27
3.14.2	Manufacturing Process for Powder Base.....	27
3.15	Number of Employees (During Construction & Regular Operation Stages).....	28
3.16	Boilers.....	28
3.17	Restoration and Rehabilitation Plans at the end to the Project Life	29
3.18	Govt. Approvals	30
4.	DESCRIPTION OF THE ENVIRONMENT	31
4.1	Methodology	31
4.1.1	Data Collection	31
4.1.2	Social Survey	31
4.1.3	Sampling Design	31
4.1.4	Questionnaires	31
4.1.5	Data Editing and Analysis	32
4.2	Review of Legal and Administrative Framework	32
4.3	Baseline Conditions	32
4.4	Physical Environment	32
4.4.1	Topography	33
4.4.2	Hydrology	33
4.4.3	Seismicity	33
4.4.4	Climate	34
4.4.5	Wind	35
4.5	Ecological Environment	36
4.5.1	Aquatic Flora & Fauna	36

4.5.2	Flora	36
4.8.3	Fauna	36
4.8.4	Water Resource	38
4.9	Socio-Economic Resources	38
4.10	Socio-Economic Profile of Study Area	38
4.11	Demographic Profile	38
4.11.1	Health Facilities	39
4.11.2	Educational Facilities	39
4.11.3	Cultural, Religious & Other Structures	39
4.12	Lab Reports of Environmental Analysis	39
4.13	Suitability of Site:	39
5.	PUBLIC CONSULTATION AND INFORMATION DISCLOSURE	40
5.1	Proponent’s Environment Management Team.....	40
5.2	The Responsible Authority.....	42
5.3	Objectives of Consultation	42
5.4	Identification of Stakeholders	42
5.4.1	Direct Stakeholders	43
5.4.2	Indirect Stakeholders	43
5.4.3	Other Departments and Agencies.....	43
5.5	Public Disclosure	43
5.6	Consultation Process.....	44
5.7	Environmental Practitioners and Experts.....	44
5.8	Affected and Wider Community	44
5.8.1	Views, Concerns and Suggestions of Various Stakeholders	45
5.8.2	Addressing Public Concerns.....	46
5.9	Acceptance Level of the Project	46
6.	POTENTIAL ENVIRONMENTAL IMPACTS AND MITIGATION MEASURES	47
6.1	General.....	47
6.1.1	What is the problem?.....	47
6.1.2	When problem will occur and when it should be addressed?	47
6.1.3	Where problem should be addressed?	47
6.1.4	How the problem should be addressed?	48
6.2	Ways of Achieving Mitigation Measures?	48

6.2.1	Changing in Planning Design.....	48
6.2.2	Improved Management and Monitoring Practices.....	48
6.2.3	Replacement/Relocation/Rehabilitation	48
6.3	Impact Assessment Methodology.....	48
6.3.1	Screening of Potential Impacts	48
6.3.2	Identification of Mitigation Measures	48
6.4	Impact Evaluation	49
6.4.1	Methodology for Impact Evaluation.....	49
6.5	Impacts Associated with Project Location.....	52
6.6	Design Related Impacts.....	52
6.6.1	Changes in Land value	52
6.6.2	Seismic Hazard.....	52
6.6.3	Emergency response.....	53
6.7	Impacts During Construction Stage	53
6.7.1	Change in land use.....	53
6.7.2	Impacts on Topography	53
6.7.3	Impacts on Soils	53
6.7.4	Impacts on Surface and Ground water	53
6.7.5	Impacts on Air Quality.....	54
6.7.6	Water Consumption	54
6.7.7	Health and Safety of Workers	54
6.7.8	Impacts on flora	54
6.7.9	Impacts on Fauna	54
6.7.10	Change of Land Appearance/layout	55
6.7.11	Employment Generation	55
6.8	IMPACTS DURING OPERATIONAL STAGE	55
6.8.1	Impacts on Climate	55
6.8.2	Employment Generation	55
6.8.3	Air Quality	55
6.8.4	Vapor/Fumes in Production Hall	56
6.8.5	Water Consumption	56
6.8.6	Wastewater Generation	56
6.8.7	Solvent Liquid Waste Generation	56

6.8.8	Solid Waste Generation	57
6.8.9	Health and Safety of Workers	57
6.8.10	Emergency Response	58
6.9	POTENTIAL ENVIRONMENTAL ENHANCEMENT MEASURES	58
6.9.1	Tree Plantation	58
6.9.2	Facility Design	59
6.9.3	Social Enhancement Measures	59
7.	ENVIRONMENTAL MANAGEMENT AND MONITORING PLANS	60
7.1	Objectives	60
7.2	Management Approach	60
7.2.1	Proponent	60
7.2.2	Contractors	61
7.3	Components of EMMP	61
7.3.1	Remedial and Mitigation Measures	61
7.4	Environmental Management and Monitoring Framework	61
7.4.1	Institutional Arrangements and Responsibilities	69
7.4.2	Proposed Monitoring Program to Assess Performance or Output of EMP	70
7.5	Proposed EMP Reporting and Reviewing Procedures	86
7.5.1	Meetings	86
7.5.2	Changes-Record Register	86
7.6	Impacts and their Mitigation Summary	86
7.7	Equipment Maintenance Details	87
7.8	Environmental Budget	87
8.	CONCLUSION AND RECOMMENDATIONS	88
8.1	Merits and Demerits	88
8.2	Recommendations	88

LIST OF TABLES

Table 1: Salient Features of the Project.....	1
Table 2: Impact Summary	3
Table 3: Details of Proponent	15
Table 4: Consultant Details.....	16
Table 5: Specification of Cyclone.....	22
Table 6: Details of the Officers	24
Table 7: Breakup of Project Cost	25
Table 8: Product List	26
<i>Table 9: Flora of the Study Site</i>	<i>36</i>
Table 10: Mammals in Study Area.....	36
Table 11: Birds in Study Area.....	37
Table 12: Reptiles in the Study Area.....	37
Table 13: Amphibians in the Study Area	37
Table 14: Insects in Study Area.....	38
Table 15: Impact Screening Checklist	50
Table 16: Impact Evaluation Matrix.....	51
Table 17: Environmental Management Plan.....	62
Table 18: Roles and Responsibilities.....	69
Table 19: Environmental Monitoring Plan	72
Table 20: Impacts Summary of Pharmaceutical Industry Processing	86

LIST OF FIGURES

Figure 1: Project Site.....	14
Figure 2: Road Access Map.....	21
Figure 3: Design of Fume Hood for Air Emission Control	22
Figure 4: Design for Septic Tank.....	23
Figure 5: Process Flow for manufacturing of Liquid Base Products	27
Figure 6: Process Flow for manufacturing of Powder Base Products.....	28
Figure 7: Design of Boiler	29
Figure 8: Seismic Zoning Map of Pakistan	33
Figure 9: Average Annual Temperatures and precipitation in Sheikhpura	34
Figure 10: Maximum temperature ranges in Sheikhpura	34
Figure 11: Annual Precipitation amounts in Sheikhpura	35
Figure 12: Annual average wind speed in Sheikhpura.....	35
Figure 13: Wind Rose diagram of Sheikhpura	35
Figure 14: Impact Assessment Hierarchy	49

1. INTRODUCTION

1.1 Project Background

The pharmaceutical industry comprises of companies involved in the research and development, manufacturing and supply, and commercialization of new therapeutic products working to bring the right treatment to the right patient at the right time. The pharmaceutical industry plays a significant role in developing medications and vaccines to reduce the incidence of diseases, to treat diseases and enhance the quality of life of people. The industry's main contribution is engaging in technological advancements through innovative research to meet the complex healthcare demands of populations. The global market for pharmaceuticals is expected to grow at an annual rate of 4.9% to \$1.3 trillion by 2020. The U.S pharma market is expected to grow to \$320 billion by 2020. The Japan market, the third largest pharmaceutical market, has a forecasted growth of 3% while the U.S has an expected growth rate of 5.6%.

The benefits of using oral therapies is influencing pharmaceutical companies to develop new and improved oral therapies to support patients who need accuracy of dose, convenience and ease of compliance to medication regimen. The demand is also due to increases in the incidence of chronic diseases and technological advancements. Novel technologies are being developed to deliver drugs via an oral route. Freedonia's recent study showed that drug delivery products in the U.S is projected to reach \$251 billion by 2019. Emerging markets in the industry include Asia and Latin America. Pharmaceutical sales are forecasted to increase at double digit rates by these new markets.

Pharmaceutical companies may deal in generic or brand medications and medical devices. They are subject to a variety of laws and regulations that govern the patenting, testing, safety, efficacy and marketing of drugs. In this regard, M/S World Biz Pharmchem (Private) Limited are aiming to construct a pharmaceutical manufacturing unit at Plot No 84-D, Quaid-E-Azam Business Park, Sheikhpura.

1.2 Project Nature and Size

The proposed project will involve the manufacturing of the quality pharmaceuticals products. They further sub categorized in Active Pharmaceutical Ingredients (API) for medicines. Proposed project will be constructed on an area of 25,636 SFT. Total capacity of the plant will be 300 Ton/Month.

1.2 Project Location

The proposed location for the establishment of proposed project World Biz Pharmchem (Private) Limited at Plot No 84-D, Quaid-E-Azam Business Park, Sheikhpura. The geographical location of the proposed area is 31°44'13.5"N 74°02'37.7"E.

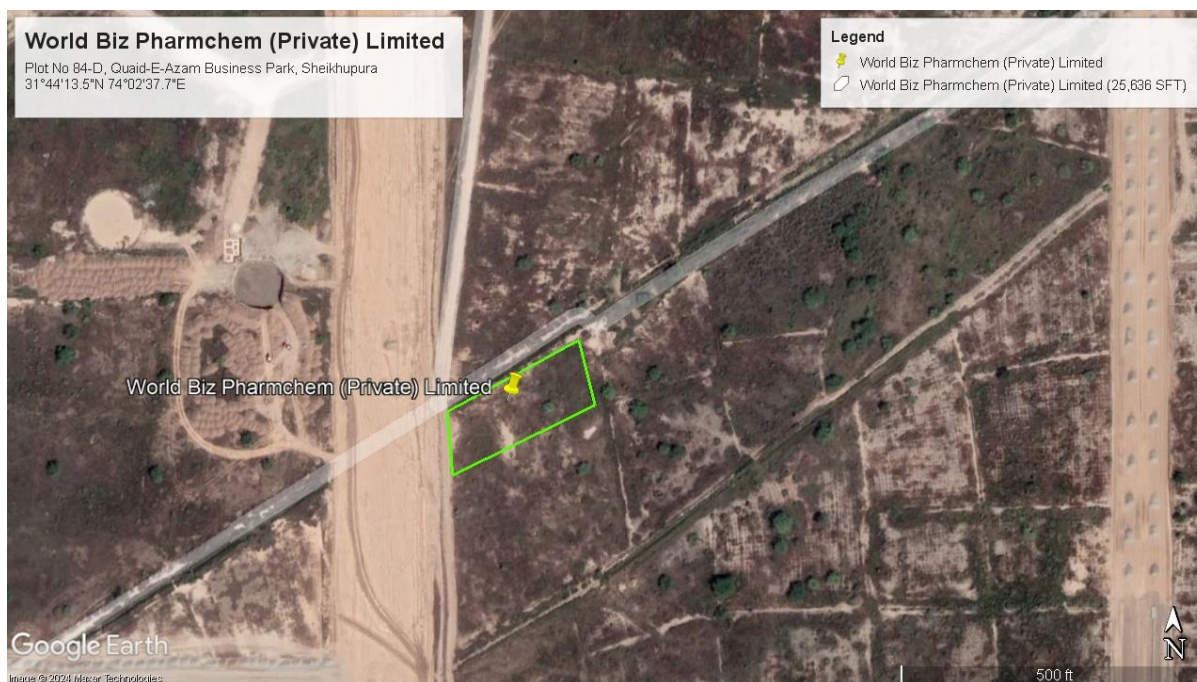

Figure 1: Project Site

Environmental sensitivity of the project includes the distance between the project area periphery from ecologically important features and socially significant infrastructures present in the study area. No ecology sensitive receptor such as; forest or reserved area is present within 5 km vicinity that could be impacted due to the installation and operation of the proposed project.

There are no particular sensitive areas as project is located far from populated areas.

1.4 Regulatory Compliance

As per IEE/EIA Regulations 2022, it is mandatory for the proponent of any development project to obtain Environmental Approval (NOC) from EPA by filing an IEE or EIA as the case may be. The said project is proposed by the proponent to meet the ever-increasing demand of medicinal products for the development. For this purpose, the proponent has decided to engage environmental consultants, M/S EnvironTech Consultants to prepare EIA Report. The purpose of this study is to identify the environmental and social baseline of the project and study area i.e., physical, biological, socio-economic, cultural changes and to assess all possible impacts anticipated during the installation and operation phases of the proposed project with the aim to find out appropriate mitigation measures to either eliminate those impacts or to bring them to acceptable level as well as to formulate Environmental Management and Monitoring Plan (EMMP) for implementation in sustainable manner. This EIA Report provides relevant information as required under the officially approved format, to help the decision makers i.e., EPA Punjab before issuing for the Environmental Approval.

Following rules, regulations and acts are considered for the commencement of the proposed project:

- Punjab Environmental Protection Act, 1997 (Amended 2012)
- Punjab Environmental Quality Standards (PEQS)
- Self-Monitoring and Reporting Rules (SMART)

- Punjab Fertilizer Act 2018
- Environmental, Health and Safety Guidelines

1.5 The Proponent

The details of the proponent of the proposed project are given below:

Table 3: Details of Proponent

1.	Name	Arshad Ali S/O Muhammad Hussain
2.	Company	World Biz Pharmchem (Private) Limited (Pvt.) Ltd.
3.	Address	House No.656, Block C, Mumtazabad, Multan.

1.6 Scope of Project

Pakistan has a very vibrant and forward-looking Pharma Industry. At the time of independence in 1947, there was hardly any pharma industry in the country. Today Pakistan has about 759 pharmaceutical manufacturing units including those operated by 25 multinationals present in the country. The Pakistan Pharmaceutical Industry meets around 70% of the country's demand of Finished Medicine. The domestic pharma market, in term of share market is almost evenly divided between the Nationals and the Multinationals.

The National pharma industry has shown a progressive growth over the years, particularly over the last one decade. The industry has invested substantially to upgrade itself in the last few years and today the majority industry is following Good Manufacturing Practices (GMP), in accordance with the domestic as well as international Guidance. Currently the industry has the capacity to manufacture a variety of product ranging from simple pills to sophisticated Biotech, Oncology and Value-Added Generic compounds.

Pakistan is a developing pharmaceutical market, with a large population and economic progress evident, but per capita drug spending was rather low at around US\$9.30 in 2007. Private spending accounts for 65% of total healthcare expenditure sourced through out-of-pocket payments, international aid and religious or charitable institutions. Pharmaceutical spending accounts for less than 1% of the country's GDP, comparable to levels in some neighboring countries but above that in some of the South Asian countries. The forecast period is likely to witness the marginal strengthening of the generics sector, albeit more in terms of volumes than values. The share of generics is also likely to increase further as major drugs come off-patent in the near term, to the likely benefit of the generics-dominated local industry.

The Pakistan pharma industry is relatively young in the international markets with an export turnover of over US\$ 100 Million as of 2007. Pakistan Pharma Industry boasts of quality producers and many units are approved by regulatory authorities all over the world. Like domestic market the sales in international market have gone almost double during last five years. The pharma industry is focusing to an Export

Vision of USD 500 Million by 2013. In the meantime, exports are also likely to be boosted by new regional and global opportunities.

Hence, keeping in view the above facts the proposed project worth establishing, and it will help in upsurge health as well as economic conditions of the country.

1.7 Details of Consultant

The proponent of the World Biz Pharmchem (Private) Limited (Pvt.) Ltd. has engaged EnvironTech Pvt L.td to carry out the EIA Study for the installation and operation of aforesaid project in accordance with Punjab-EPA guidelines. For this purpose, the company engaged the group of professionals which comprises of environmental specialists and social scientists. The details of the consultant are given below:

Table 4: Consultant Details

Consultant Details		
Sr#	Consultant	EnvironTech Consultants
1	Consultant	EnvironTech Consultants
2	Address	Office no.11 (2 nd floor) Centre point Plaza, Main Boulevard Lahore.
3	Contact No.	0303-4342302
Focal Person		
Kamal Ahmed Cheema (C.E.O)		

To prepare EIA Report of the respective project the company engaged the following experts. The details of the experts are given in appendices:

1.8 Purpose of Report

The main objectives of this EIA Study were:

- ↳ To determine and record the state of the environment of the project area to establish a baseline in order to assess the suitability of the project in that proposed area
- ↳ To identify pre-construction/design, construction and operation activities and to assess their impacts on environment
- ↳ Provide assistance to the proponent for planning, designing and implementing the project in a way that would eliminate or minimize the negative impact on the biophysical and socio-economic environment and maximizing the benefits to all parties in the cost-effective manner
- ↳ To present mitigation and monitoring plan for smooth implementation of the suggested mitigation measures and supervise their efficiency and effectiveness
- ↳ To provide opportunity to the public for understanding the project and its impacts on the community and their environment in the context of sustainable development
- ↳ Prepare an EIA Report for submission to the EPA, Punjab for Environmental Approval (NOC)

2. SCREENING AND SCOPING

2.1 Screening/Type and Category of Project

Section 12 of Punjab Environmental Protection Act, 1997 (amended 2012) states “No proponent of a project shall commence construction or operation unless he has filed with the Government Agency designated by Federal Environmental Protection Agency or Provincial Environmental Protection Agencies, as the case may be, or, where the project is likely to cause an adverse environmental effects an Environmental Impact Assessment (EIA), and has obtained from the Government Agency approval in respect thereof.” Punjab Environmental Protection Act provided the guidelines for categorizing the projects. According to **Schedule-II** of IEE and EIA Regulations, 2000; the proposed project falls under **Category B (Manufacturing and Processing)** i.e., the project requires an EIA Study. Thus, an EIA Report is being prepared and submitted accordingly for approval.

The proposed project is the manufacturing of antibiotics under 49 different Products.

2.2 Scoping:

1. Spatial and Temporal Boundaries of Environmental Assessment:

Temporal and spatial boundaries for the effects assessment are defined by the characteristics of the project and the VECC being assessed. These boundaries encompass time periods and areas during and within which the VECCs are likely to interact with or be influenced by the project.

- Temporal Extent (during construction and operation)
- Spatial Extent (local or widespread)

2. Views, Concerns and Suggestions of Various Stakeholders

Community showed a lot of concerns; a few are being mentioned here:

- ✚ Removal of shrubs and trees should be avoided to the extent possible
- ✚ The project will become the source of income for local to earn their livelihood easily and honorably
- ✚ The area will become further industrialized
- ✚ For the solid waste management and waste disposal, proper disposal techniques should be adopted
- ✚ Employment opportunities will be generated, and locals should be hired on the priority basis
- ✚ The air pollution is one of the major impacts of the proposed project, so ambient air quality should be monitored regularly
- ✚ Water spraying/sprinkling should be done on the regular basis during construction phase to avoid dust emissions
- ✚ Removal of shrubs and trees should be avoided to the extent possible
- ✚ Good relations with the local communities will be promoted by encouraging Contractor to provide opportunities for skilled and unskilled employment to the locals as well as on-job training

- ✚ The contractor should prefer hiring local labor from adjacent nearby villages
- ✚ Indigenous trees around the facility should be planted to control air pollution and as the compensation
- ✚ Noise reducing barriers should be installed to reduce noise pollution as the nearest community lies within the radius of 0.5 KM

Concerns

- ❖ Workers should be hired from local community
- ❖ Proper disposal of solid waste should be practiced
- ❖ Proper disposal of wastewater should be practiced
- ❖ Indigenous trees around the facility should be planted to control air pollution
- ❖ Removal of shrubs and bushes should be avoided to the extent possible

3. Significant impacts and factors to be determined

The proposed project is of manufacturing of pharmaceutical products. The nature of the land is industrial and current status of land is open land having native vegetation such as Neem, Kikar, Safeda and wild grass. The study area is leveled and industrial land. In addition, to the noise and fugitive dust emissions during the development phase solid waste management and disposal issues may arise along with wastewater disposal issues. There are few minor impacts associated with the operation of manufacturing unit includes the management of the municipal solid waste generated during the, raw-material storage which will be managed according to local practices of area.

The impacts from the establishment of World Biz Pharmchem (Private) Limited (Pvt.) Ltd. Private Limited will occur during the construction and operation due to the civil work involved and the people residing in the project area. These issues included; noise generation, fugitive dust emissions, solid waste management, wastewater disposal, top-soil removal, Health and Safety issues and change in the geographic features of the area. These all problems should be addressed on-site where they are being generated, to avoid the residual or adverse impacts.

2.3 Alternatives

The details of the site alternatives and technology alternatives are discussed below:

Site Alternatives

No other site alternative was available to be consider as feasible option for the installation of the plant as the land is owned by the proponent. The proposed site was selected because of the following reasons;

- 1) The site is at the safe distance from the nearest residential area.
- 2) The site is well connected to the other parts of the city through metaled road.
- 3) No human settlements displacement or relocation associated with the project development and operation

- 4) Operation of the proposed processing unit in the respective zone will provide job opportunities to local people and will improve their socio-economic status of the study area as 50 employees will be hired during the operational phase

Project Alternatives.

Although Pakistan's pharmaceutical and healthcare sectors are expanding and evolving rapidly, about half the population has no access to modern medicines. Clearly this project presents an opportunity, but much more work needs to be done by the government and industry's stakeholders.

Pharma companies are facing challenges with developing new medicines and meeting the complex demands of clients. Unprecedented challenges in the pharmaceutical industry are raising concerns about innovations that increase R&D, administrative and sales cost. Some of the challenges include:

- Expiring patents
- Increase in competition by generic companies
- Slower sales growth rates
- Decrease in the number of innovative drugs under development
- Tighter regulatory reviews and standards

The Pakistan Pharmaceutical Industry is a success story, providing high quality essential drugs at affordable prices to Millions. Technologically, strong and self-reliant National Pharmaceutical Industry is not only playing a key role in promoting and sustaining development in the vital field of medicine within the country but is also well set to take on the international markets.

As the proposed project is need of time so no project alternative is considered by the proponent.

Environmental Alternatives:

No important religious, archaeological, recreational site or ecologically/declared protected area and human settlement exists within proximity of the selected site i.e., within 5 Km which is a safe distance. In view of these facts, it can be concluded that the selected site is best suited for the project and will not pose any adverse impact or threat on any component of the environment.

Economic Alternatives:

The technology selected for establishment of above stated project will be economical viable than alternatives present as compared to majority of the other available production technologies, but it will be most efficient and convenient to use.

3. DESCRIPTION OF PROJECT

This section of the study concentrates on details of the project and its salient features; such as its location, site layout, objectives, selection of alternative sites and technology, cost and magnitude of operation at various phases and process employed for the processing of the proposed project.

3.1 Objectives of Project

The main objectives of the proposed project are as under:-

- ❖ Responding to the country's national priorities to produce quality pharmaceutical products at latest art of technology plant with international health standards without polluting environment
- ❖ To develop long term strategic business relationship with customers and suppliers.
- ❖ Long-term relationship with multinational and quality conscious companies will ensure to ZCI commitment to product quality and customer satisfaction,
- ❖ Delivering innovative, high-quality products that help people live better.
- ❖ To conserve and protect environment by using latest techniques.
- ❖ To provide the employment to the people.
- ❖ To change the social life style of the area
- ❖ Revenue generation for the Govt.
- ❖ To upgrade the socio-economic conditions of the area

3.2 Location and Layout of Project

The proposed location for the installation of proposed project of World Biz Pharmchem (Private) Limited (Pvt.) Ltd. is at Plot No 84-D, Quaid-E-Azam Business Park, Sheikhpura. The geographical location of the proposed area is 31°44'13.5"N 74°02'37.7"E.

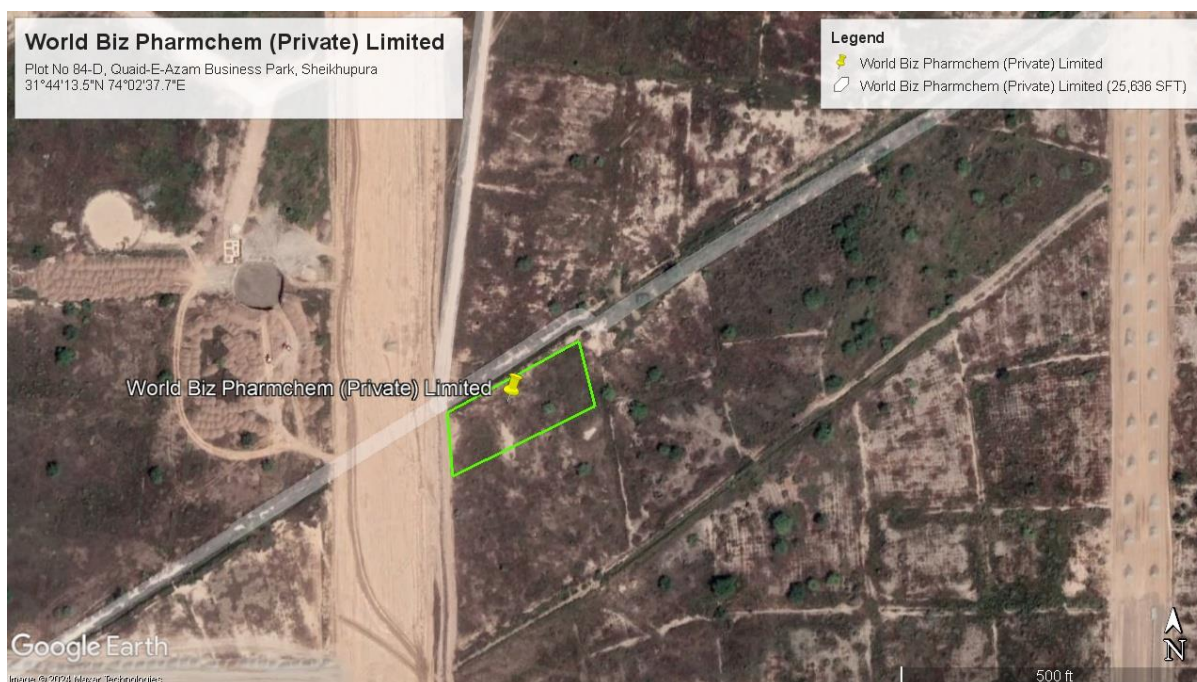

Proposed Project Site

3.3 Land Use on Site:

The surface land in and around the project area is leveled and is industrial in nature. No ecology sensitive receptor such as; forest or reserved area is present within 5 km vicinity that could be affected due to the installation and operation of the aforesaid project.

3.4 Road Access

The project site is linked to metaled Road.

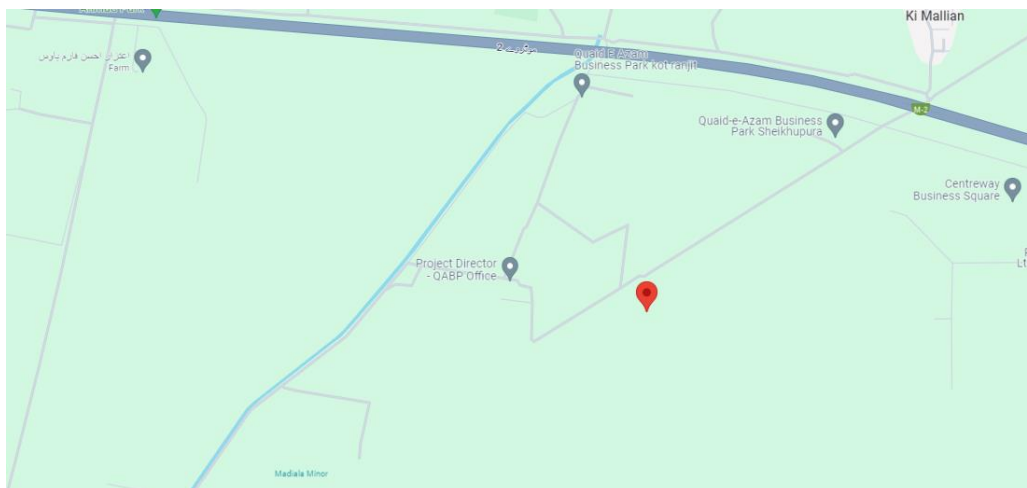

Figure 2: Road Access Map

3.5 Vegetative Features

The area around the project is industrial in nature. The main plantation around the project area includes; safeda, bari, neem and kikar.

3.6 Amenities

The following social amenities are present at site and the management of the waste (solid waste and effluents) is explained in sub-sections below:

3.6.1 Electricity

Electricity will be supplied by Industrial Estate sourced by WAPDA(LESCO).

3.6.2 Ground Water Resource

During constructional and operational phase ground water will be consumed which will be supplied by the Punjab Small Industrial Estate. For construction purposes water will be pumped from ground from the depth of 250ft. and 200-300 liters/day will be used for the overall consumption.

3.7 Management Plans

Following management plans will be employed to reduce the impact of the proposed activity

3.7.1 Air Emissions

Particulate dust will be generated during construction phase and to deal with the air emissions during the operational phase cyclones will be installed with the efficiency of more than 95% keeping in view of PEQs. For safety purpose the workers dealing with the process activities will be provided with masks, safety

shoes and all other necessary PPEs. To reduce the public nuisance native trees will be planted on the boundary to reduce the nuisance and to reclaim the disturbed soil effectively.

Design and Working principle of Fume Hood

A fume hood is a ventilated enclosure in which gases, vapors and fumes are contained. An exhaust fan situated on the top of the building pulls air and airborne contaminants through connected ductwork and exhausts them to the atmosphere. then in a combination horizontally and vertically, provides some protection to the hood user by acting as a barrier between the worker and the experiment. The slots and baffles direct the air being exhausted. The airfoil or beveled frame around the hood face allows more even airflow into the hood by avoiding sharp curves that can create turbulence

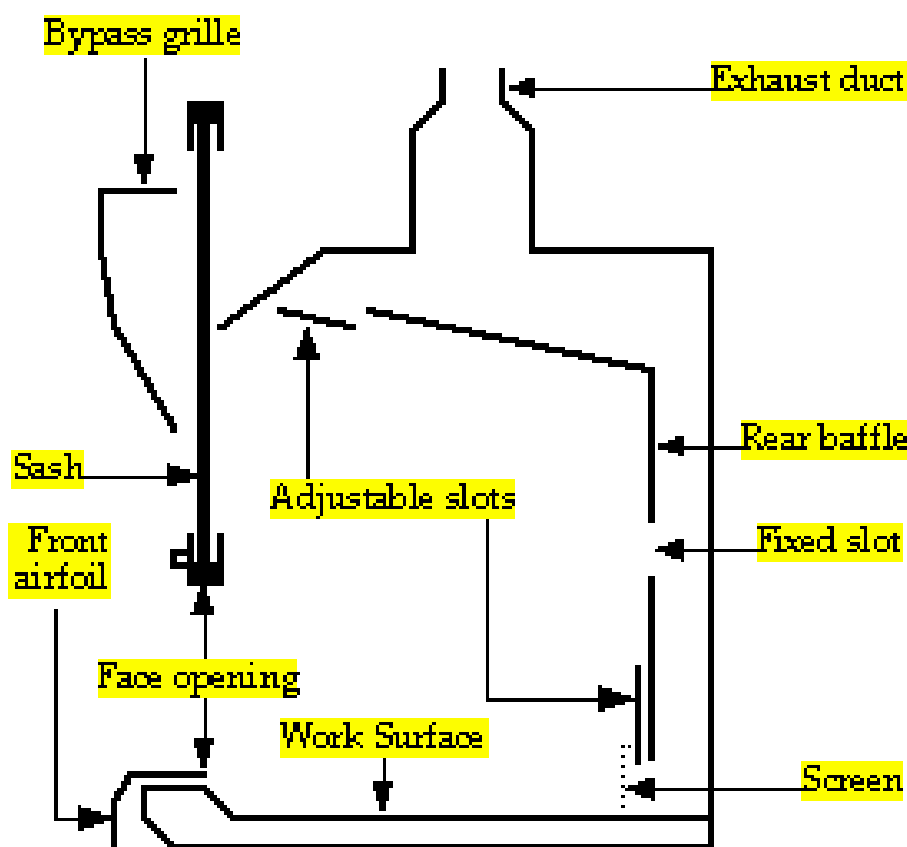

Figure 3: Design of Fume Hood for Air Emission Control
Table 5: Specification of Fume Hood

Dimensions	Construction	Electrical	Controller	Power Supply
1800 x 680 x 1450 mm	<p>Main Body Phenolic resin laminates</p> <p>Support Frame Mild Steel / CRCA extrusions with an oven-baked epoxy polyester powder-coated finish</p> <p>Interior Baffle System Phenolic resin laminates</p> <p>Airfoil Stainless steel grade 304</p>	<p>Cabinet Load (A): 8 Amps</p> <p>Fluorescent Light: 1 no.</p> <p>Power Consent: 04</p>	Rocker Switches	1 Phase, AC 220 V, 50 Hz

3.7.2 Wastewater Management and Disposal

In the proposed project the wastewater will be generated from process as well as municipal activities. The wastewater from the process activities will be treated by a wastewater treatment plant with the capacity of 1000 liters/shift design of treatment plant is attached as an Annexure with the EIA report. The municipal amount of the wastewater generated will be 200 liters (0.2m³) by the sanitation activities if per person wastewater generation is 20 liters and the manpower is 10 (20*10). This wastewater will be discharged in settling tank and ultimately in the drain. Water balance at site will be:

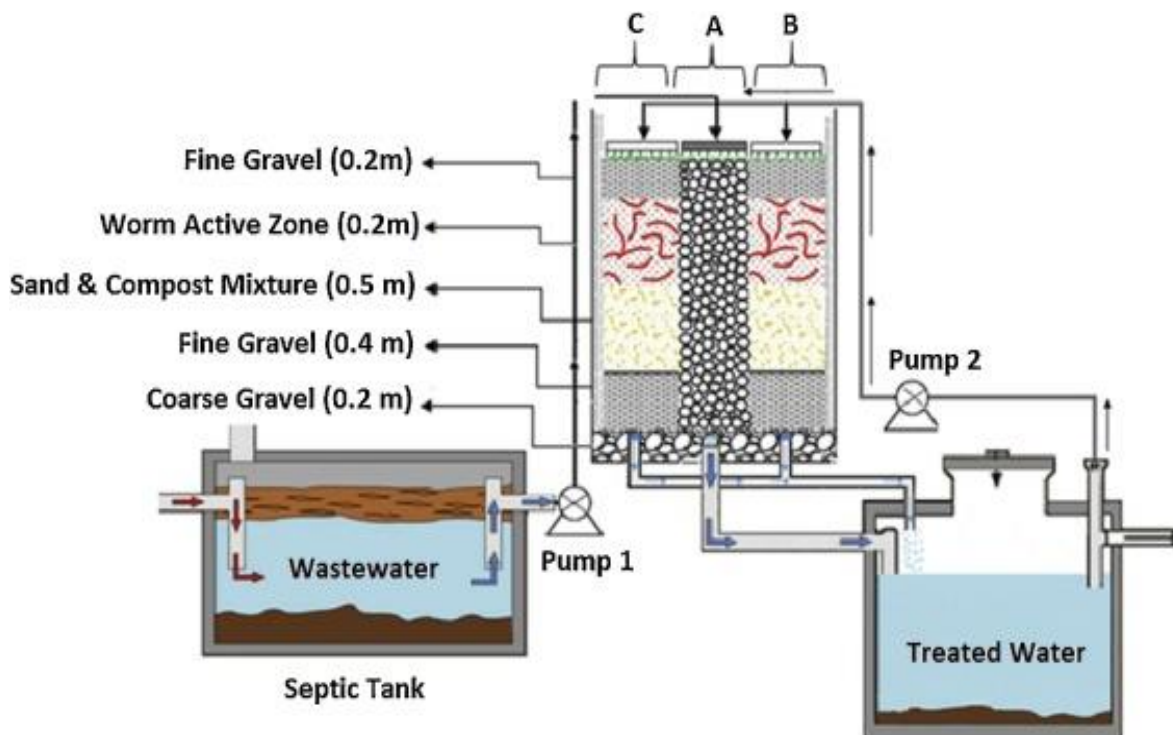

Figure 4: Design for Septic Tank

It is proposed that tree plantation will also be carried out. The generated wastewater will be consumed for on-site horticultural activities after primary treatment.

3.7.3 Waste Management

Most of the solid wastes that will be generated during the daily work can be divided into 3 main categories:

- i. The ordinary household wastes that the workers and the staff generate all-day around; e.g. kitchen and food residues, clothing, personal unneeded articles, etc.
- ii. Municipal residues; e.g. grass clipping, strings, scraps je sort, etc.
- iii. Waste medicines and Product Packing.

Quantity of solid waste will 25 kg/day and is going to be dumped in the containers (number, capacity and type will be identified and sufficient for the needs) which will be emptied by the municipality trash collection cars according to the acting regulations under the supervision of the concerned authorities. Collecting the trash/garbage will be followed on daily basis in disposable environmentally friendly shopping bags.

And the waste generated during the process activities or afterwards like waste medicines etc. will be send to a waste disposal facility.

3.8 Staff/Manpower

During construction phase of the proposed project about 50-55 people will be engaged for development of the project. Around 50+ workers will be required during process related activity. The breakdown of the workers employed is given below:

Table 6: Details of the Officers

Sr#	Designation	No.
1	Production Manager	03
2	Deputy Manager	03
3	Asst. Manager	04
4	HSE Manager	03
5	Electrical Manager	02
6	Mechanical Manager	02
7	Metallurgical Manager	01
8	HSE Inspectors	03
Total Number of Officers		20

3.9 Emergency Preparedness

Emergency response preparedness committee will be formulated consisted of heads of all departments and nominated members. Project Manager will be the head of the team who will chair the Committee. In the case of emergency, he will immediately inform the concerned authorities. HSE Manager will be responsible for on-site HSE management.

First aid facilities will be available at facility which will include; blankets, hot water bottles, sterilized dressing, snake bite kit, cotton and iodine (2% alcohol).

3.9.1 Safety Trainings

Skilled, semi-skilled and un-skilled staff will be provided with proper training about the work and safety practices that need to adopt during the process activities.

3.9.2 Use of Drugs and Narcotics

Drugs and narcotics are strictly prohibited during working hours in working area. Smoking will be only allowed during rest timings at properly isolated places.

3.9.3 Personal Protective Equipment's

Following Personal Protective Equipment (PPEs) will be provided to the workers:

- ✓ Safety Helmet
- ✓ Safety Shoes/Dry Shoes
- ✓ Dust Mask

- ✓ Safety Gloves
- ✓ Safety Jackets
- ✓ Earmuffs
- ✓ Insulating Gloves and Suits

3.10 Cost and Magnitude of Operation

The proposed project includes the production of different pharma products. List of machinery is attached as an annexure with the EIA report.

- The activities will include:
- Installation of the machinery.
- Purchase of lab instruments
- Installation of the filtration and liquid unit.
- Health and Safety Management at site
- Transportation of raw-material and final product
- Plantation of trees

Table 7: Breakup of Project Cost

Sr. No	Description	Amount Rs Millions
	Land Purchasing	25.0
	Civil Works	22.0
	Plant and Machinery	35.13
	Laboratory	2.70
	Licensing	2.00
	Environmental Budget	2.00
Total		88.72

3.11 Land ownership Documents

Site selected for the proposed project installation is owned by the proponent. Land ownership documents have been attached as Annexure of EIA Report, which clearly shows that the selected area for the installation of World Biz Pharmchem (Private) Limited (Pvt.) Ltd. has been owned by the proponent through a proper channel.

3.12 Schedule of implementation

It is projected that the construction phase of entire project will be started after getting environmental approval from EPA Punjab and complete in the period of 5-6 months. Activities involved are:

- Assessment of environmental impacts and its mitigation measures
- IEE approval, other local issues
- Implementation of recommended alteration in system, if required
- Commencement of operation

3.13 Process Description

The project includes the manufacturing of pharmaceutical products.

3.13.1 Basic Raw Materials Required by the Proposed Unit

The basic raw materials such as Liquid Solvent, Solids for Reaction and Gases will be used for manufacturing of finished products. 2200 ton/Month of raw materials would be required for the project. Raw material for each product is given in table-10 in front of each product.

Area Reserved for Raw Material

↳ Area reserved for raw material store is 1075 SFT.

3.14 Finished Products

The final products which will be produced by the proposed project/unit are given in the table below.

Table 8: Product List

Sr. No.	List of Product	List of Raw Materials
1	Ciprofloxacin Hydrochloride	Piperazine anhydrous 7-Chloro-6-Fluoro-1-cyclopropyl-1,4-Oxoquinoline-3-Carb-Oxylic Acid Fluoroquinolonic Acid (Ciprofloxacin Q-Acid)
2	Moxifloxacin Hydrochloride	Moxifloxacin Q Ester 2,8-Diazabicyclo [4,3,0] nonane (Moxifloxacin Side Chain) Propionic Anhydride
3	Levofloxacin	N-Methyl Piperazine 9,10-Difluoro-2,3-Dihydro-3-Methyl-7-Oxo-(3s)-7h-Pyrido(1,2,3-De)-1,4-Benzoxazine-6-Carboxylic Acid (Levofloxacin Q Acid)
4	Norfloxacin	Ethyl Quinolonic Acid
5	Azithromycin	D,D, Aza Erythromycin
6	Clarithromycin	Erythromycin, 6-O-Methyl-2, 4-Bis-0-(Trimethylsilyl),9-[0-(1-Ethoxy-1-Methylethyl) Oxime] Erythromycin Thiocyanate
7	Sulfamethoxazole	Acetyl SMZ intermediate
8	Omeprazole	2-Chloromethyl-3,5-Dimethyl-4-Methoxypyridine Hydrochloride Omeprazole Sulfide
9	Paracetamol	Para Amino Phenol
10	Pyrazinamide	2-Cyanopyrazine
11	Naproxen Sodium	DL Naproxen/ Naproxen
12	Ibuprofen	Isobutylhydrotope Aldehyde
13	Simvastatin	Simvastatin Ammonium Salt
14	Atorvastatin Calcium TH	2-[2-(4-fluoro-phenyl)-2-Oxo-1-phenyl ethyl] 4-methyl-3-Oxo-perntanoic Acid phenyl Amide (Diketone) Tert-butyl [(4R, 6R)-6-(2-aminoethyl)-2,2-dimethyl-1, 3-dioxan-4-yl] Acetate (Amino Compound)
15	Amlodipine Besyalte	Amlodipine Base Crude
16	Montelukast Sodium	Quinolinylnl Propanol
17	Mefenamic Acid	2-Chlorobenzoic Acid

3.14.1 Manufacturing Process for Liquid Base Products

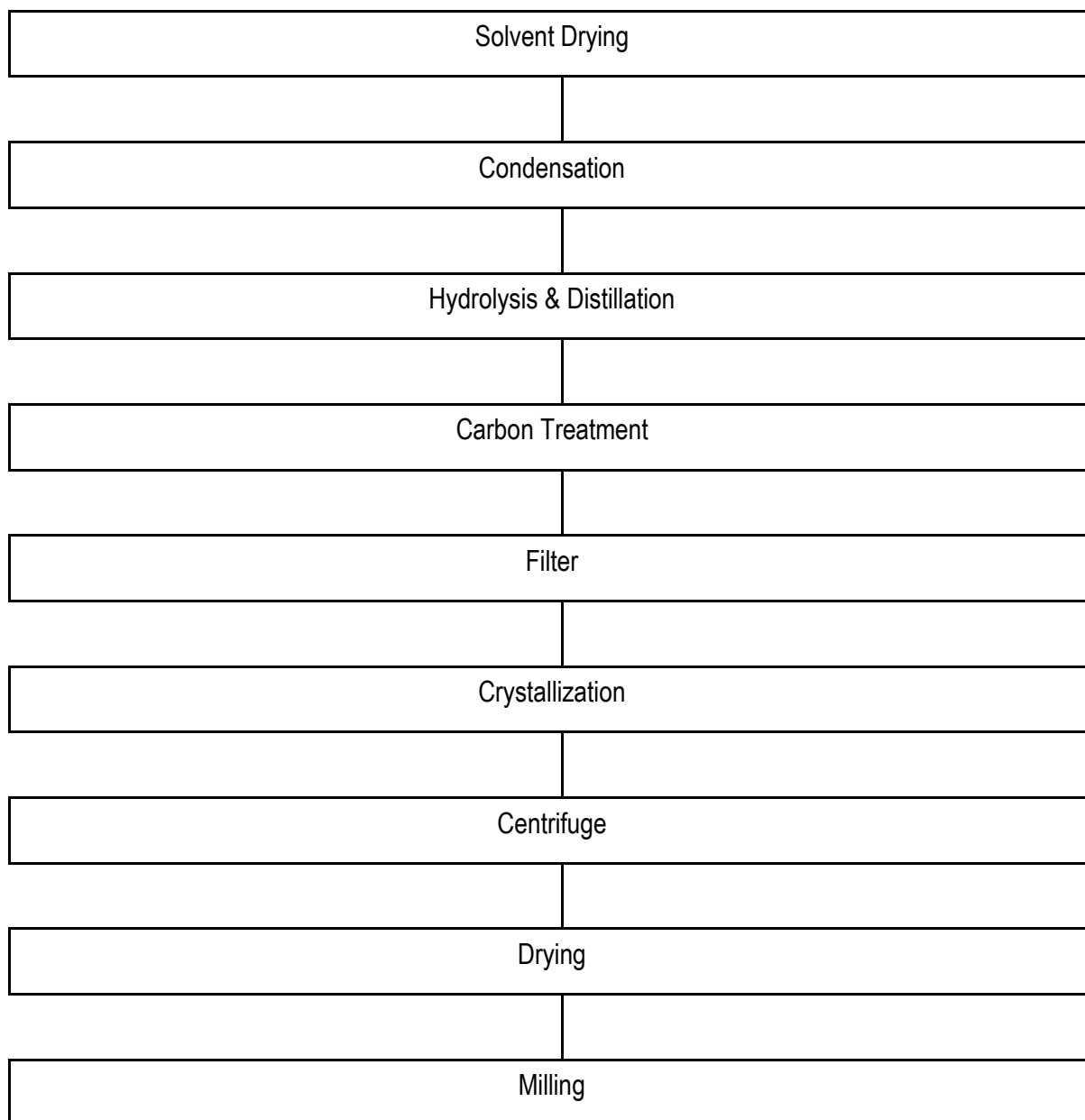
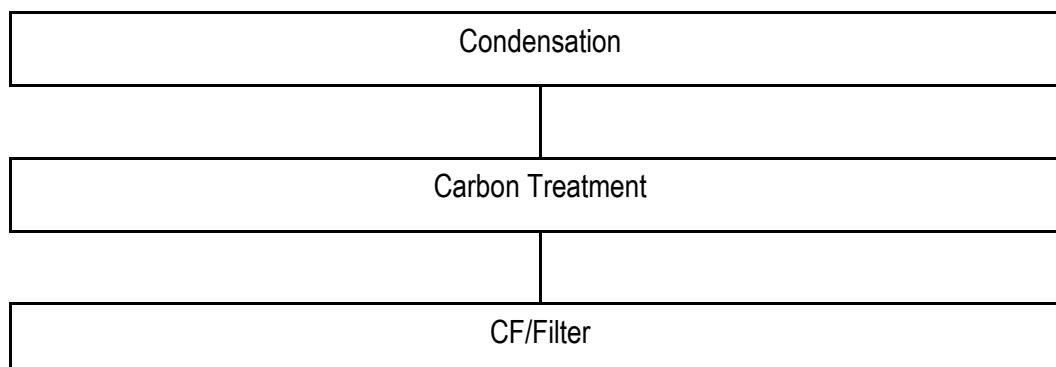

Figure 5: Process Flow for manufacturing of Liquid Base Products

3.14.2 Manufacturing Process for Powder Base



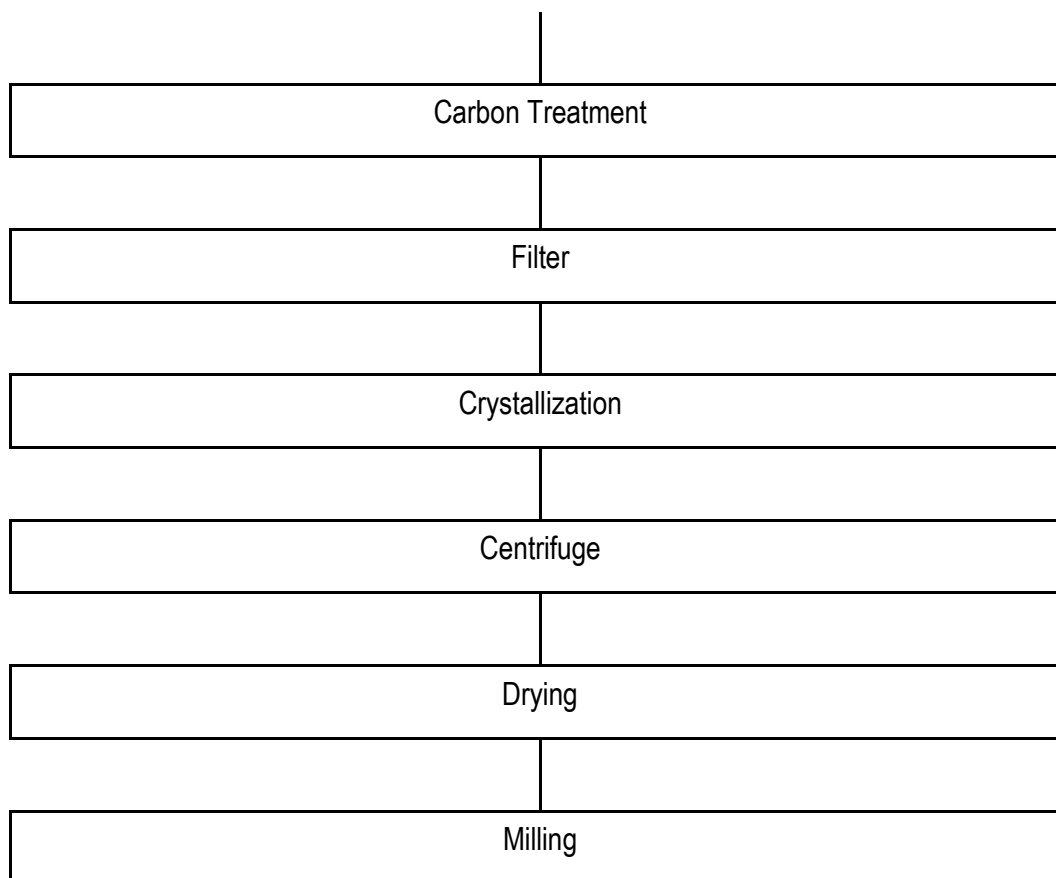

Figure 6: Process Flow for manufacturing of Powder Base Products

3.15 Number of Employees (During Construction & Regular Operation Stages)

During construction and operational phase of the proposed project about 50-55 people will be engaged for development of the project.

3.16 Boilers

A Natural gas fired boiler with capacity of 2 Ton will be used in proposed project.

BOILER

A natural gas fired boiler with capacity of 4 Tons will be used in proposed project.

Sources:

- Natural gas.
- Diesel will be an alternate source

Operation Instructions

1.Remove trapped air before running

- a) Notices for feed water pipe line
- b) Venting of gas pipe line

2.Inspection before running

Open feed water system and gas fuel system valves to check they are normal. Confirm the operation valves are on the correct positions and the pressure of the gas supply is in the allowable working range.

3. Starting the boiler

- a. Turn the electrical power switch ON.
- b. Turn the running switch ON.
- c. Make sure the booster pump is working properly
- d. Check the water level in the water column
- e. Turn ON the burner switch then the air within the furnace will be purged.
- f. . The burner will be fired at combustion state after 20-40 seconds.

4. Attention during running

- a) Check the force draft fan and feed water pump has the unusual sounds.
- b) Check that the gas pressure is same as the previous day.
- c) Check whether the color of the smoke emission through the chimney is white or black.
- d) Check whether the water level in the water column has extreme variation.
- e) Open the main steam valve slowly

5.Shutdown

- a) Turn the firing and the running switches OFF.
- b) Turn the electrical power switch OFF.
- c) Shut off the feed water, the fuel systems and the main steam valves.

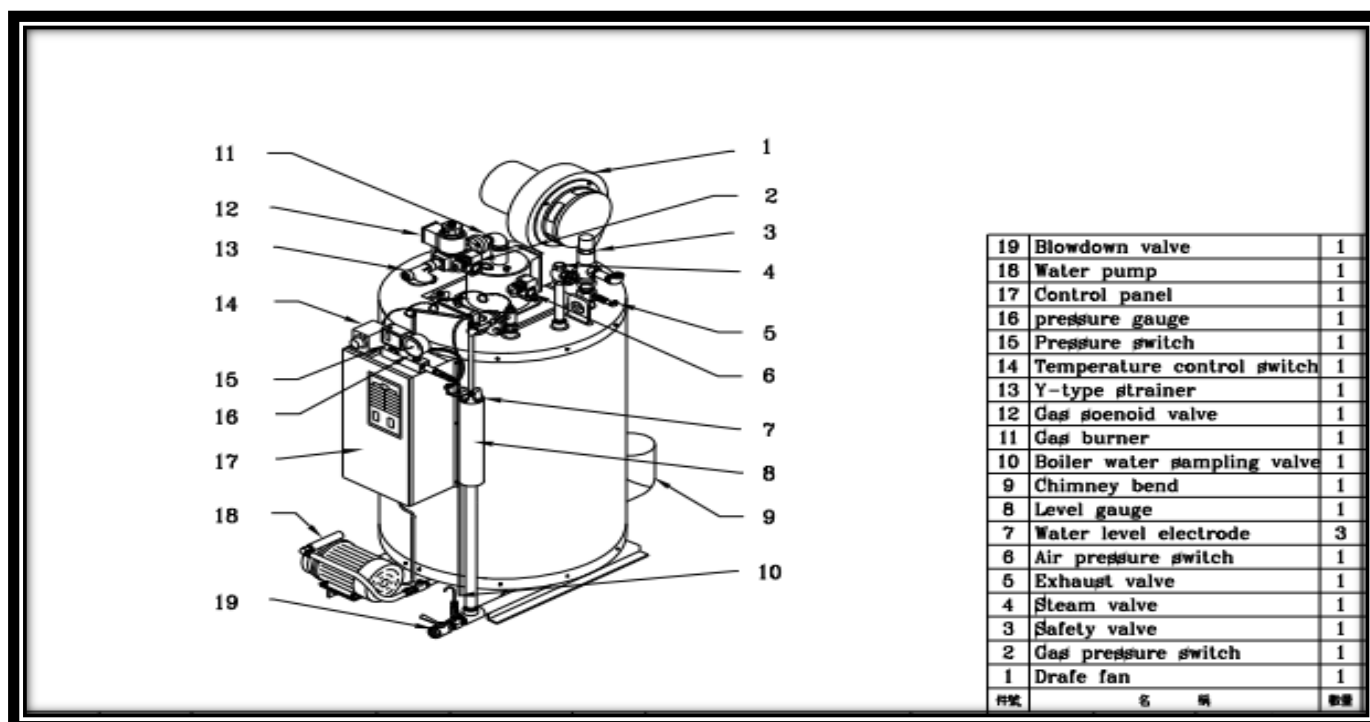

Figure 7: Design of Boiler

3.17 Restoration and Rehabilitation Plans at the end to the Project Life

The estimated life of the first phase of the project is approximately 50 years. Much before the project approaches end of its first life cycle it will be completely renovated, refurbished and even new/latest state of the art machinery will replace the old one. All civil structures and related infrastructures will be extensively renovated. Even during its first life cycle, pre-emptive modifications, replacements and

refurbishing will be carried from time to time under the “order of the day principle”. This will ensure enhancement of the life of the project at very nominal costs. In this way the project life will be further enhanced for another hundred years or so. All activities will be carried out in accordance with prevailing environmental management laws and controls so as to avoid any damage to any segment of environment of human health around the project site.

3.18 Govt. Approvals

So far, the Environmental Approval from the EPA, Punjab, Lahore is the major requirement when the environmental approval is issued construction work will be started.

4. DESCRIPTION OF THE ENVIRONMENT

This chapter provides baseline data (physical, biological and socio-economic parameters) related to the project and study area. The information has been compiled by using primary and secondary data resources. This chapter also refers to the theoretical analysis of the methodology adopted for collection of baseline data. The underlying principles and practices adopted in this regard are also discussed.

4.1 Methodology

The methodology employed to collect the baseline data and information regarding the social structure and various related parameters as discussed in sub-sections below:

4.1.1 Data Collection

The primary data was collected by visiting the project area and its communities in its nearby vicinity. The secondary data regarding physical parameters (topography, geology, seismology, and climate) was obtained by visiting relevant various government departments and their official websites. The biological parameters such as flora and fauna were studied by preparing a floristic list based on visual observation and fauna was studied by using opportunistic approach. The species were recorded with reference to their existence in the project area. Information on wildlife fauna species (mammals, amphibians, reptiles, birds, etc.) in the assessment area was compiled based on opportunistic observation, gathering the existing information and consultation with local experts, community members and government and Non-Government Organizations (NGOs). The socioeconomic aspects were studied and analyzed by studying detailed village profile and by conducting household surveys.

4.1.2 Social Survey

The purpose of social survey was to record the present condition of the people living in the project area and to assess the expected project impacts on their life, subsistence systems and socio-cultural conditions. Prior to conducting the field surveys, the following steps were taken:

- Clear boundaries of the project area were identified
- Decided the sampling procedure in order to draw a representative sample size of the target population and households
- Developed the tools for data collection i.e. questionnaires to assess the socio-economic status of the area

4.1.3 Sampling Design

Social baseline data of the persons residing in the study area has been estimated and collected through random sampling by using pre-developed questionnaires.

4.1.4 Questionnaires

In order to test the validity and reliability of the proposed questionnaires, they were reviewed to assess whether questions needed to be clarified, changed or re-sequenced and then a final editing of

questionnaires was conducted prior to their application in the project area. The sample of socio-economic questionnaires used is attached as Annexure.

4.1.5 Data Editing and Analysis

The filled questionnaires and recorded information were compiled by the same field investigators who were involved in the data collection. This was done immediately after completing the field investigations. Data sets were processed. Analysis of the data and preparation of conclusions in the minimum possible time was done using statistical techniques of data analysis.

4.2 Review of Legal and Administrative Framework

The objective of reviewing legal and administrative framework is to obtain information on all legislation pertaining project development. The Socio-Environment Team of EnvironTech Consultants (PVT) Ltd. reviewed the environmental policies, national, international and provincial laws and guidelines relevant to the development of project which helped in systematic identification of impacts.

4.3 Baseline Conditions

This chapter provides baseline data (physical, biological and socio-economic parameters) related to the project and study area

4.4 Physical Environment

Pakistan Can be divided into five broad physiographical regions. These are the mountainous regions of the north, the western highlands and plateaus, the sub-mountains Indus region, the Potohar Plateau, Salt Range, and the Indus Plain. Brief description of these regions is given below:

Region	Characteristics	Location	Height
Northern Mountainous	Hindu Kush Karakoram and Himalayan Mountain Ranges	Northern Part of KPK, Gilgit Agency, Northern Areas and Kashmir.	Rises above 8,000m
Western Highlands and Plateaus	Toba Kakar, Sulaiman, Central Baruhi, Saihan, Central Makran, Makran Coastal and Kirthar Ranges	Mainly in Baluchistan, also parts of Sindh and KPK	Between 1,200 to 3,000 m
Sub-Mountains Indus	Alluvial filled Basins	Plains of Peshawar Kohat and Bannu	Less than 1,000 m
Potohar Plateau and Salt Range	Flat to gently undulating surface, broken by gullies,	Mainly northern parts of Punjab, some parts of KPK	Less than 1,000 m
Indus Plain	Flood plains of the Indus, Jhelum, Chenab Ravi and Sutlej Rivers	Punjab and Sindh	Less than 1,000 m

4.4.1 Topography

Sheikhupura the city of Punjab province, eastern Pakistan. In the town center stands a fort of the Mughal emperor Jahangir (completed 1619) that also served as the 19th-century residence of one of Ranjit Singh's queens; outside the city, the massive Hiran Minar tower overlooks the countryside. Sheikhupura is connected by road and rail with Lahore (25 miles [40 km] southeast) and various other cities. It is an industrial center that makes food products and textiles. The city is in a section of alluvial plain known as the Bar tract, which is irrigated by the Chenab Canal system.

Sheikhupura is an industrial city in the northwest of Punjab province, Pakistan. The city is also the administrative headquarter of the Sheikhupura district and is approximately 38 km from Punjab's provincial capital, Lahore. The town is famous for its historical monuments and also known as the city of Mughals, where emperors come for hunting. The city is also well-known for its booming industry. District Sheikhupura is bounded on the North by Gujranwala and Hafizabad districts, on the North-East by Narowal district, on the West and South-West by Nankana Sahib District, on the East by Lahore district.

Project Site:

The proposed project site is located in District Sheikhupura.

4.4.2 Hydrology

Groundwater from depth of 100 ft can be used for drinking and other purpose. Groundwater is the major source of water in the study area, which is extracted with the help of pumps and motors. The groundwater extracted is used to fulfill various domestic, irrigation and industrial needs. Ground water quality report of area is annexed. No surface water body is present within 5 km radius of the project site.

4.4.3 Seismicity

According to Seismic Zoning of Pakistan, the project area lies in Zone 2A and represents minor to moderate damage due to earthquakes.

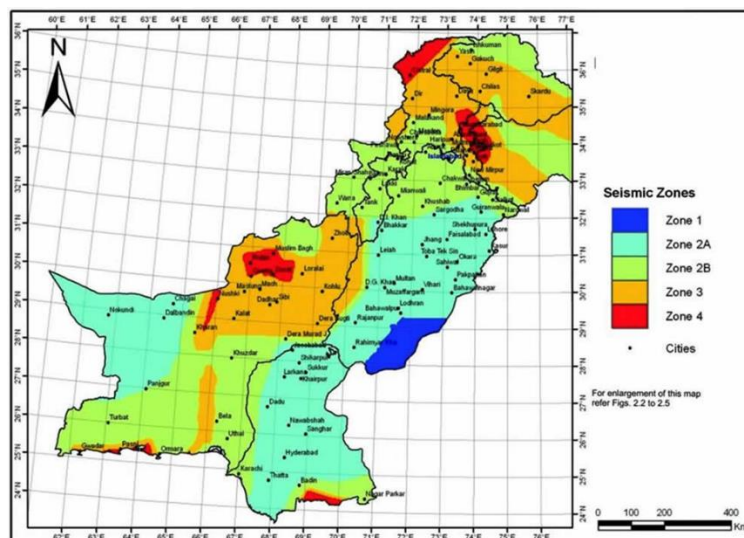

Figure 8: Seismic Zoning Map of Pakistan

4.4.4 Climate

Due to its high evaporation rate, Sheikhpura features hot desert-like climatic conditions according to Koppen-Geiger classification. The climate of the district can see extremes, with a summer maximum temperature 44°C and a winter temperature of 4.0°C. The mean maximum and minimum temperature in summer are 43.5°C and 18.0°C respectively. In winter it peaks at around 19.4°C and 4.1°C respectively. The summer season starts from April and continues till October. May, June and July are the hottest months. The winter season starts from November and continues till March. December, January and February are the coldest months. "The bulk of monsoon precipitation occurs in July and August, with monthly averages of 115.0 mm and 89.8 mm respectively. Minimum rainfall occurs in the month of November which is 3.0 mm" (PMD).

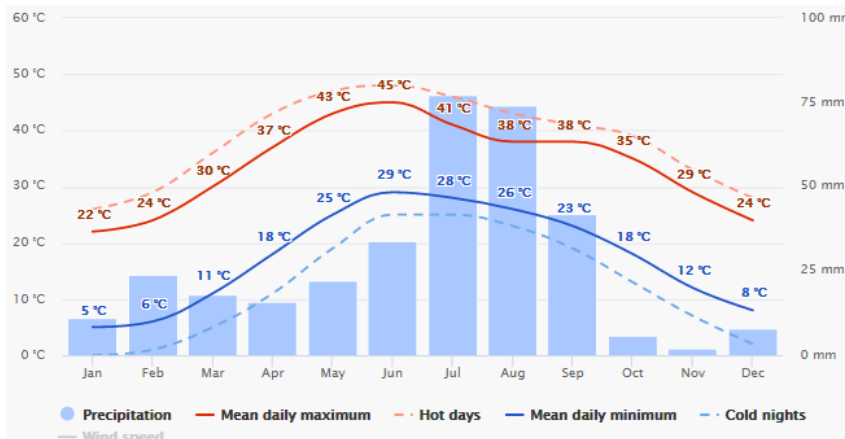

Figure 9: Average Annual Temperatures and precipitation in Sheikhpura

The "mean daily maximum" (solid red line) shows the maximum temperature of an average day for every month for Sheikhpura. Likewise, "mean daily minimum" (solid blue line) shows the average minimum temperature. Weather in Sheikhpura is influenced by Subtropical Dry Semiarid Steppe climate. Low-latitude dry climate. Evaporation exceeds precipitation on average but is less than potential evaporation.

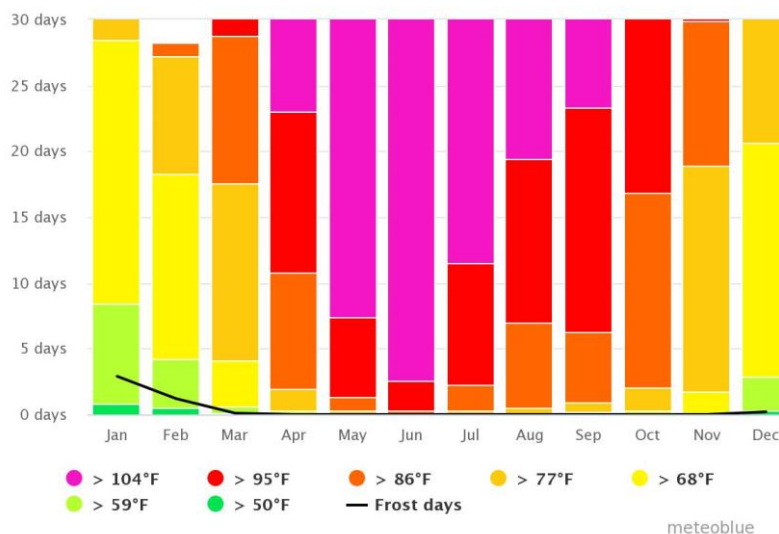

Figure 10: Maximum temperature ranges in Sheikhpura

The graph shows the monthly number of sunny, partly cloudy, overcast and precipitation days. Days with less than 20% cloud cover are considered as sunny, with 20-80% cloud cover as partly cloudy and with more than 80% as overcast.

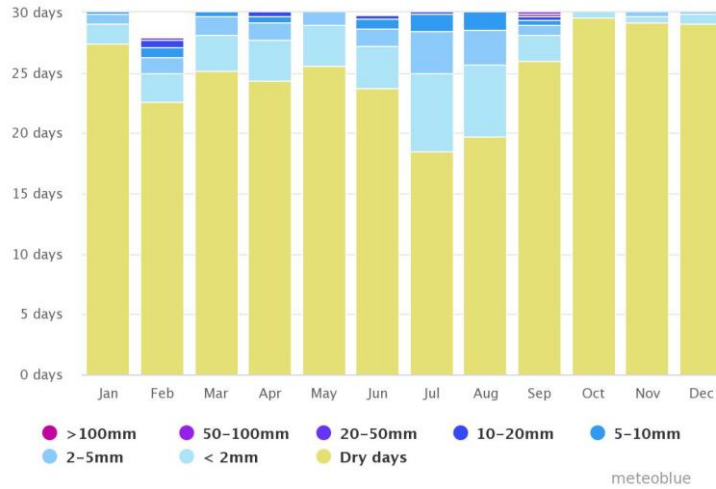

Figure 11: Annual Precipitation amounts in Sheikhupura

4.4.5 Wind

The diagram for Sheikhupura shows the Max and Average Wind speed and Wind Gust.

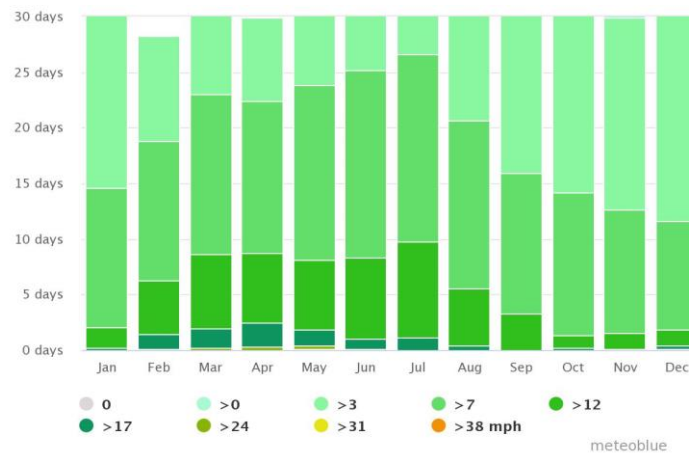

Figure 12: Annual average wind speed in Sheikhupura

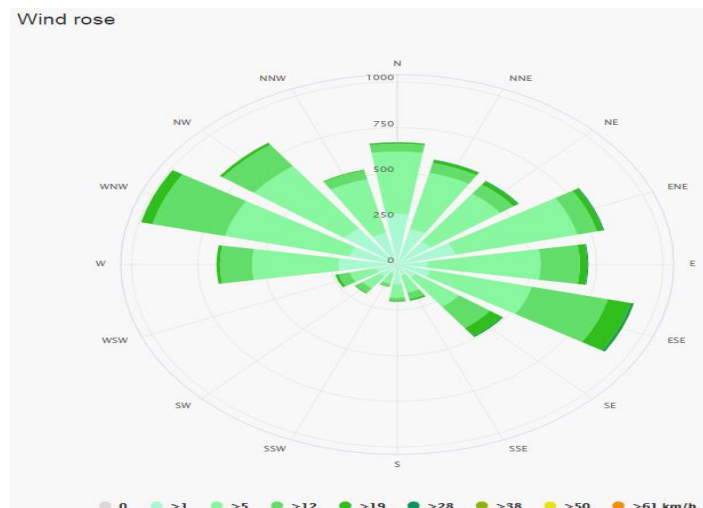

Figure 13: Wind Rose diagram of Sheikhupura

The wind rose for Sheikhpura shows how many hours per year the wind blows from the indicated direction. Example SW: Wind is blowing from South-West (SW) to North-East (NE).

4.5 Ecological Environment

Sheikhpura is enriched with the presence of natural flora and fauna, although with the growing population and development activities, the presence of some has been somewhat affected. They are discussed in detail below.

4.5.1 Aquatic Flora & Fauna

No aquatic ecosystem (i.e. canal, stream, river or pond) observed within or around the study area, which omits the possibility of any kind of aquatic species that may be harmed due to the establishment of proposed project.

4.5.2 Flora

The project is located in industrial area. The project site has no vegetative cover, hence, no trees or vegetation will be removed. The dominant tree species in study area include; Eucalyptus, Neem, and Kikar. The crops present around project site include wheat, sugarcane and common grass. The nomenclature including common, English, local and botanical names of the flora found in the study area are presented in Table

Table 9: Flora of the Study Site

S#	Common Name	Scientific Name
1	Neem	<i>Azadirachta indica</i>
2	Kikar	<i>Vachellia nilotica</i>
3	Safeda	<i>Eucalyptus globulus</i>

4.8.3 Fauna

For study of fauna in the project area, field guides and books were consulted. On the other hand field observations were conducted along with the interviews of local community members about the fauna of the area. The equipment used in field included cameras, binoculars and GPS device (wherever required). It is important to note that there is a number of factors which can change the findings of such survey. It may be pointed out that the pattern of seasonal migration of small birds varies depending upon each specie. During the construction activity in project area, no important biological feature will be damaged or disturbed as the project falls in industrial area.

The fauna commonly found in District Sheikhpura includes; Hares, Falcon, Eagle, Quail, Starling, Jungle Pigeon, Russian Sparrow, Doves, King Fisher, Parrot, Crow and Local Sparrow.

Commonly found mammals in the area include; dogs, cats, horses, house-rats, squirrels, porcupines and bats. However, Small Indian Mongoose and Indian Palm Squirrel are also found in the District Sheikhpura.

Table 10: Mammals in Study Area

S#	Common Name	Scientific Name
1	Rat	<i>Rattus</i>
2	Bat	<i>Chiroptera</i>
3	Small Indian Mongoose	<i>Herpestes javanicus</i>
4	Indian Palm Squirrel	<i>Funambulus palmarum</i>
5	Porcupines	<i>Erethizon dorsatum</i>
6	Squirrels	<i>Sciuridae</i>

The commonly found bird's species include; House Sparrow, Crow and some of them are mentioned below with scientific names.

In District Sheikhpura reptiles such as Snakes (Cobra and Kraits), Spiny Tailed Lizard and Fringed Toed Lizard are common in the tract, but cases of snake bites are very rare, as these reptiles have been either killed by expanding urbanization or they have moved away.

Table 11: Birds in Study Area

S#	Common Name	Scientific Name
1	House Sparrow	<i>Passer domesticus</i>
2	House Crow	<i>Corvus splendens</i>
3	Pigeon	<i>Columbidae</i>
4	Bulbul	<i>Pycno notidae</i>
5	Teetar	<i>Francolinus francolinus</i>
6	Parrot	<i>Psittaci forms</i>
7	Titodi	<i>Vanellus indicus</i>

Table 12: Reptiles in the Study Area

S#	Common Name	Scientific Name
1	Snake	<i>Serpentes</i>
2	Spiny Tailed Lizard	<i>Uromastix hardwickii</i>
3	Fingered Toed Lizard	<i>Acanthodactylus cantoris</i>
4	Earthworm	<i>Lumbricina</i>

The amphibians commonly seen around the project area, especially during the rainy season includes;

Table 13: Amphibians in the Study Area

S#	Common Name	Scientific Name
1	Common Frog	<i>Rana temporaria</i>
2	Indus Valley Toad	<i>Bufo stomaticus</i>

A large number of insects are present due to open fields in the project site. Few of these insects are known to cause diseases in local population. Following is a list of commonly observed insects at the site:

Table 14: Insects in Study Area

S#	Common Name	Scientific Name
1	Black Ants	<i>Paratracheaiognicornis</i>
2	Dragon Fly	<i>Dragon Fly</i>
3	House Flies	<i>Musca domestica</i>
4	Butter Flies	<i>Parnassiusbalucha</i>
5	Honey Bees	<i>Apismellifera</i>
6	Wasps	<i>Anagyrus pseudococci</i>
7	Grasshopper	<i>Melanoplus differentialis</i>
8	Mosquito	<i>Anophlese sp.</i>

No endangered species are found at the site. The area has not been identified as ecologically sensitive area by wildlife department.

4.8.4 Water Resource

The main source of the water consumption is the ground water which is being pumped from 200 ft borehole and its being used in the study area for domestic purposes. To check the quality of the water in the area, ground water was collected and analyzed. The ground water was collected from bore hole adjacent to the project area.

4.9 Socio-Economic Resources

This section provides collective information about the existing socio-economic and environmental condition of the project area within the AOI. The different types of socio-economic aspects were covered such as demographic profile, occupation, education and health facilities. This data helped in identifying major interventions for the development of Environmental Management and Monitoring Plan (EMMP). The study also helped to assess the positive or adverse impacts on local community.

4.10 Socio-Economic Profile of Study Area

This topic provides an overview of the baseline information relating to the socio-economic environment of the project area and the AOI. The socio-economic study gives information about the demographic profile, occupation, education and health facilities in the project area.

4.11 Demographic Profile

The Demographic Studies are the major source of any city's Socio-Economic profile. Demographic Studies relate to population. Population studies are extremely important from Town Planning point of view. Until and unless we know about population in detail, we cannot do successful planning. All aspects

of population, such as sex-age composition, trend of migration, social, cultural, political, economic and administrative works, values and facilities have to be related to planning considerations and decisions. Individuals are the raw material of society; therefore, society is directly affected by size, growth, composition and distribution of its individuals. The term population refers to the number of individuals living within a geographical area at a given time.

Different community individuals in the vicinity of the project area have different family sizes depending upon their living setups. Average family size is however 5-7 individuals per family with 1-2 earning hands per family.

4.11.1 Health Facilities

As the project site is in an Industrial zone. DHQ Hospital Faisalabad is located at the distance of approx. 16 Km radius. Some other private health center is present as Villages area present in the vicinity of the project site.

4.11.2 Educational Facilities

As the project site is not located in any residential area. However, the villages located around project site have few governments primary schools.

4.11.3 Cultural, Religious & Other Structures

No cultural, religious and other structures are present in the close proximity of the project area that needs to be relocated. Villages present around the project site have mosques and imam bargah.

4.12 Lab Reports of Environmental Analysis

Testing of different parameters was done from a certified laboratory named SEAL to check the quality of different environmental parameters. The copy of the lab reports of these parameters (ambient air analysis, water quality analysis and noise) is attached at Annexure of this IEE Report.

4.13 Suitability of Site:

Comprising all assessment of above baseline data there will be no significant ecological/ environmental impact expected in and around the present selected project site, hence it is suitable for the proposed project.

5. PUBLIC CONSULTATION AND INFORMATION DISCLOSURE

Public consultation refers to the process by which the concerns of local affected persons and others who have a plausible stake in the environmental impacts of the project or activity are ascertained with a view to taking into account all the material concerns in the project or activity design as appropriate. According to the IEE and EIA Review Regulations, public consultation is mandatory for any socio-environmental study.

5.1 Proponent's Environment Management Team

Following are the designated roles and responsibilities of the employees involved in the monitoring and management of the adverse impacts and will be appointed after operation of project starts.

Roles and Responsibilities		
Sr#	Concerned Persons	Duties
1	The Project Manager	<p>Following will be the responsibilities of the Project Manager</p> <ul style="list-style-type: none"> • Ensure that the contractor is aware of all specifications, legal constraints, standards and procedures pertaining to the project specifically with regards to environment. • Ensure that all stipulations within the EMMP are communicated and adhered to by contractor(s) • Monitor the implementation of the EMMP throughout the project by means of site inspections and meetings. This will be documented as part of the minutes of the site meeting documents • Ensuring project execution within defined budget and timelines • Conducting regular check of the project status and meetings with project team • Provide support and guidance to project team as and when needed • Project Manager is expected to continually monitor and improve the overall performance of their operation
2	HSE Manager	<p>In addition to the health and safety responsibilities held by staff, managers and supervisors must do whatever is reasonably practical to ensure that both the workplace and the work itself are safe. This includes:</p> <ul style="list-style-type: none"> • Ensuring that staff are appropriately trained and supervised • Identifying, assessing and managing health and safety risks • Consulting with workers (including staff, affiliates and contractors): <ul style="list-style-type: none"> i. Health and safety risk assessments

		<ul style="list-style-type: none"> ii. Decisions are made about the measures to be taken to eliminate or control these risks iii. Health and safety risk assessments <ul style="list-style-type: none"> • Implementing health and safety risk management programs relevant to their operations, teaching, research and consulting functions and work environment • Reporting (to the Human Resources Unit), investigating and responding to all hazards, accidents, incidents and taking action to control the risk • Assisting with the development, implementation and maintenance of a return to work program for injured staff. • Be fully conversant with the EIA and conditions of its approval • Be fully conversant with the EMMP • Be fully conversant with all relevant environmental legislation, policies and procedures, and ensure compliance • Convey the contents of this document to the contractor site staff and discuss the contents in detail with the Project Manager and Contractor • Undertake regular and comprehensive inspection of the site and surrounding areas in order to monitor compliance with the EMMP • Take appropriate action if the specifications contained in the EMMP are not followed • Monitor and verify that environmental impacts are kept to a minimum, as far as possible • Review and approve construction methods, with input from the Site Manager, where necessary • Ensure that activities on site comply with all relevant environmental legislation • Compile progress reports on regular basis, with input from the Site Manager, for submission to the Project Manager, including a final post excavation audit • Liaise with the Site Manager regarding the monitoring of the site • Report any non-compliance or remedial measures that need to be applied • All environmental problems arising on the construction area will be reported to the Site Manager by the Environmental Manager. Reports on such problems will be submitted to the Project Manager by the Site Manager
--	--	---

5.2 The Responsible Authority

Impact assessment survey and public consultation sessions held with different stakeholder groups that may be impacted by the proposed project commencement. The consultation process was carried out in accordance with the guidelines laid by Punjab-EPA. The objectives of this process were to:

- ⊙ **Share information with stakeholders on proposed project installation and operation**
- ⊙ **Assess the impacts on the physical, biological, and socioeconomic environment**
- ⊙ **Understand stakeholder concerns regarding various aspects of the project commencement**
- ⊙ **Find out valuable suggestions by the stakeholders to improve the proposed project design**
- ⊙ **Understand the perceptions, assessment of social impacts and concerns of the affected people/communities of the project area**
- ⊙ **Find out the awareness level and situation of acceptability to identify any issues for the implementation of the proposed project**
- ⊙ **Invite people to express their views about the positive/negative impacts on their lifestyles and environment**
- ⊙ **Disclose information about contact offices/officers for any complaints/queries**

It is envisaged, there will be no social impact being foreseen due to the construction and operation of World Biz Pharmchem (Private) Limited (Pvt.) Ltd. at the proposed location. This EIA Report includes all the comments, which were taken into account during the social survey and preparing the definitive development concept for the installation and operation of World Biz Pharmchem (Private) Limited (Pvt.) Ltd. in G. Public consultation performas is attached as Annexure of this EIA Report.

5.3 Objectives of Consultation

Public consultation plays a vital role in studying the impacts of the proposed project on stakeholders in successful implementation and execution of the project. It provides an opportunity to exchange knowledge with the beneficiaries and affected parties. Referring particularly to a project related to environmental assessment, involvement of the public is all the more essential, as it leads to better and more acceptable decision-making. The overall objective of the consultation with the stakeholders is to help verify the environmental and social issues, besides technical ones, that have been presumed to arise and to identify those which are not known or are specific to the project. In fact, discourse with many who have thoroughly observed the site conditions in the pre-development phase, goes a long way in updating the knowledge and understanding.

5.4 Identification of Stakeholders

All the people who are directly or indirectly affected or concerned with the project are the stakeholder. Besides the living population of the surrounding areas, some other stakeholders were identified and

contacted which enlisted below. They are the key players including; shops, public and government offices, schools, university, hospitals, hotels, international agencies and the NGOs. Not only published material, brief or other literature were obtained on request, but also noted their views and the concerns, in an official capacity as well as on the personal basis. Following stakeholders are identified for this project:

Project Affected Persons (PAPs) include the settled families, either property owners or the tenants, businessmen (big, shopkeepers, vendors, etc.), employees of the commercial entities. PAPs are of two types, for instance:

5.4.1 Direct Stakeholders

No disturbance in the local community is being foreseen due to the installation of the aforesaid project as the community is at a safe distance. No property loss is being envisaged due to the construction of the World Biz Pharmchem (Private) Limited (Pvt.) Ltd.

5.4.2 Indirect Stakeholders

Indirect impact will occur on those who are living or doing business within a Project Area of Influence (AOI). In the case of the proposed project, the citizens of nearby small towns will get opportunities of being employed. So, in the early development stages and during the operational phase the people will be benefited due to the installation of the World Biz Pharmchem (Private) Limited (Pvt.) Ltd.

5.4.3 Other Departments and Agencies

Following departments are related to the project in public consultation:

- ➔ **Government agencies responsible to deal with the project related activities**
- ➔ **Government Agencies directly, indirectly or widely involved in the execution and monitoring of the proposed project**
- ➔ **Government departments such as TMA and Planning & Development Department, Forest Department, Agricultural Department, Industrialist around the estate and working on the other development activities are considered as indirect stakeholders**
- ➔ **Workers of political, cultural, religious or social scientific bodies, directly or indirectly related to the project**

5.5 Public Disclosure

Public disclosure is the outcome of all such activities where the public is involved at least in the information sharing process. This is an integral part of the process. So, before the proponent applies for NOC to the Punjab-EPA, this disclosure will be distributed properly among all stakeholders. It is the responsibility of the proponent and the consultants to display a public disclosure document in prominent places where community has easy access.

5.6 Consultation Process

Information disclosure, public consultation and discussion regarding the various aspects of the project with the people of the area are necessary. This process is intensified during the EIA Studies, and separate rounds of public consultations were held. Surveys were carried out in order to investigate physical, biological and socioeconomic resources falling within the immediate AOI of the project. Primary data collection included:

- ☑ **Data collection regarding the socioeconomic condition of the study area**
- ☑ **Pre-testing of socioeconomic survey tools in the field**
- ☑ **To consult the locals for collection of information on biological environment**

Various meetings with the stakeholders were held the following objectives:

- ➔ **Share information with stakeholders on the proposed project and expected impacts on community in the vicinity of the project**
- ➔ **Understand stakeholders' concerns regarding various aspects of the project, including the existing condition of the upgrading requirements, and the likely impact of construction and operation activities**
- ➔ **Provide an opportunity to the public to influence the project design in a positive manner**
- ➔ **Obtain local and traditional knowledge, before decision making**
- ➔ **Increase public confidence about the proponent, reviewers and decision makers**
- ➔ **Reduce conflict through the early identification of controversial issues, and work through them to find acceptable solutions**
- ➔ **Dissemination of information through discussions, education and liaison**
- ➔ **Documentation of information narrated by the stakeholders and mitigation measures proposed by the stakeholders**
- ➔ **Incorporation of public concerns and their address in the EIA; and eliciting their comments and feedback**
- ➔ **Create a sense of ownership of the proposal in the mind of the stakeholders**

5.7 Environmental Practitioners and Experts

Officers of government departments and industries were consulted by the socio-environmental team of the consultants and concerned details about the project were noted down through personal interviews, group meetings, etc., in their offices, for instance. List is attached as an annexure.

5.8 Affected and Wider Community

In addition, to the use of direct methods to evince the response of the various stakeholders in the population of the study area was ascertained by conducting a sample survey, through specially formatted questionnaires (attached in the Annexure of this EIA Report). Questions posed to the public were related

to creation of possible impacts, adverse impacts and beneficial impacts, including; employment opportunities, income generation activities, change in living standards and provision of the amenity.

- Disclose the proponent plan of the construction of the proposed facility**
- To share information on the design and specifications of proposed project works**
- To analyze the expected impact on the socioeconomic environment**
- To understand their concerns regarding various aspects of construction and operation**

5.8.1 Views, Concerns and Suggestions of Various Stakeholders

Community showed a lot of concerns; a few are being mentioned here:

- ↪ **Removal of shrubs and trees should be avoided to the extent possible**
- ↪ **The project will become the source of income for local to earn their livelihood easily and honorably**
- ↪ **The area will become further industrialized**
- ↪ **For the solid waste management and waste disposal, proper disposal techniques should be adopted**
- ↪ **Employment opportunities will be generated, and locals should be hired on the priority basis**
- ↪ **The air pollution is one of the major impacts of the proposed project, so ambient air quality should be monitored regularly.**
- ↪ **Water spraying/sprinkling should be done on the regular basis during construction phase to avoid dust emissions**
- ↪ **Removal of shrubs and trees should be avoided to the extent possible**
- ↪ **Good relations with the local communities will be promoted by encouraging Contractor to provide opportunities for skilled and unskilled employment to the locals as well as on-job training**
- ↪ **The contractor should prefer hiring local labor from adjacent nearby villages**
- ↪ **Indigenous tress around the facility should be planted to control air pollution and as the compensation**
- ↪ **Noise reducing barriers should be installed to reduce noise pollution**

Concerns

- Workers should be hired from local community**
- Proper disposal of solid waste should be practiced**
- Indigenous tress around the facility should be planted to control air pollution**
- Removal of shrubs and bushes should be avoided to the extent possible**

5.8.2 Addressing Public Concerns

The best mechanism of effective communication between the community and the proponent is the by the nomination of the representative of the community and all the issues/concerns must be recorded for future reference. This representative may be the member of the Grievances Redressed Committee (GRC).

a. Grievances Redressed Committee

Grievances Redressed Committee (GRC) will be formulated by the proponent to address the concerns of the locals during the construction phase. The main role of the GRC will be to resolve the issues of the community associated with the proposed project, if any.

5.9 Acceptance Level of the Project

The opinions of the respondents were noted during the public consultation. The majority of respondents (88%) of were in favor of the proposed project. They expect that installation of the proposed unit will also increase the economic value of local assets. According to them the proposed project will boost the employment opportunities, mobility access to resources and social amenities.

6. POTENTIAL ENVIRONMENTAL IMPACTS AND MITIGATION MEASURES

6.1 General

The potential environmental impacts related to the proposed project have been studied related to design, location, construction and operational stages of the Project. Environmental protection measures are recommended to eliminate adverse environmental impacts or to reduce them to an acceptable level within the prevailing legislative and regulatory framework.

Impacts are evaluated on the basis of magnitude, immediacy and sustainability. Evaluation criteria are as follows:

Magnitude

Type of impact (direct, indirect, cumulative)

✚ Immediacy

Temporal extent (during construction, after construction)

✚ Spatial extent (local, widespread)

Sustainability and Reversibility

✚ Mitigability (fully, partially)

✚ Monitoring (fully, partially)

The basic purpose of mitigation measures is to reduce the impacts of the establishment of pharmaceutical manufacturing unit on the socio-environment up to the maximum possible extent. The mitigation measures are suggested based on the following parameters:

6.1.1 ***What is the problem?***

The proposed project is of manufacturing of pharmaceutical industry which are organic in nature. The nature of the land is open land. The project is vacant plot in industrial estate. In addition, to the noise and fugitive dust emissions during the development phase solid waste management and disposal issues may arise along with wastewater disposal issues. There are few minor impacts associated with the operation of manufacturing unit includes the management of the municipal solid waste generated during the, raw-material storage which will be managed according to local practices of area.

6.1.2 ***When problem will occur and when it should be addressed?***

The impacts from the establishment of pharmaceutical manufacturing unit will occur during the construction and operation due to the civil work. These issues included; noise generation, fugitive dust emissions, solid waste management, wastewater disposal, top-soil removal, Health and Safety issues and change in the geographic features of the area. These all problems should be addressed on-site where they are being generated, to avoid the residual or adverse impacts.

6.1.3 ***Where problem should be addressed?***

The problem will be generated from site development and operation of the unit. So, it should be addressed on source i.e. at site within the same timeframe.

6.1.4 How the problem should be addressed?

Proper mitigations measures will be provided according to the nature of the impacts/problems. For example, against dust emissions sprinkling of water may be done on regular basis, for solid waste proper solid waste management and disposal practices may be adopted, to manage liquid waste proper treatment may be made before discharging into the receiving body. The change landscape is estimated to be quite minor and the removed topsoil may be used to reclaim the disturbed areas.

6.2 Ways of Achieving Mitigation Measures?

Following ways will be adopted to reduce the impacts of the pharmaceutical manufacturing:

6.2.1 Changing in Planning Design

There is no endangered and threatened species present in the project area. Moreover, there is not any human settlement or infra-structure that will be dislocated or dismantled due to the proposed project development. Hence, there is no need to change the design of project.

6.2.2 Improved Management and Monitoring Practices

The anticipated impacts had been reduced significantly by adopting better management activities, as it will be carried out for betterment of the society. While environmental monitoring will be conducted on the regular basis to keep the sources of the air pollution, wastewater generation, noise and public nuisances in-check. Following practices that need to be adopted to reduce the impact significantly:

6.2.3 Replacement/Relocation/Rehabilitation

The proposed project is located in open land where there is no sensitive area, human population or preserved natural resource is present which could be impacted due to the commencement of the proposed project. No replacement, relocation and rehabilitation will be required for the commencement of the aforesaid project.

6.3 Impact Assessment Methodology

The impact assessment methodology for the installation of the pharmaceutical manufacturing unit is given below:

6.3.1 Screening of Potential Impacts

Based on site visit, observation, brain storming, provided information and social interviews, significant impacts were anticipated and evaluated. Then qualitative and quantitative (where possible) assessment of these anticipated impacts is to be carried out.

6.3.2 Identification of Mitigation Measures

After anticipation and screening of significant impacts, certain mitigation measures are to be provided in order to enhance benefits of project and reducing impacts. These measures can be classified as:

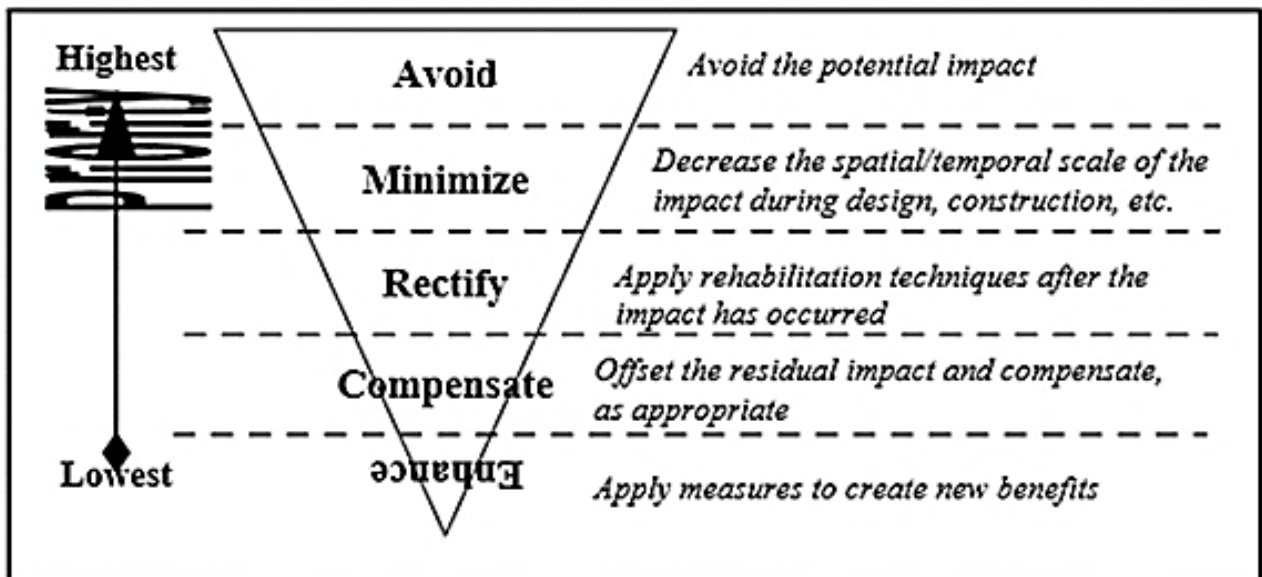

Figure 14: Impact Assessment Hierarchy

6.4 Impact Evaluation

Impact screening checklist and project impact evaluation matrix have been developed to evaluate the potential impacts of the establishment of pharmaceutical plant on the basis of set procedures as given in the environmental guidelines by Punjab EPA.

6.4.1 Methodology for Impact Evaluation

These tools have been used to identify the significance and magnitude of the impact as well as the nature, reversibility and extent:

1. An Impact Screening Checklist
2. Project Impact Evaluation Matrix

Following is given a brief description of assessment tools:

a) Impact Screening Checklist

The impact screening checklist is developed to screen out the potentially insignificant environmental and social impacts from the potentially significant adverse environmental and social impacts during planning & designing, construction and operational phases of the project. The objective of the impact screening process is to assess the significance of the issues related to the air, water, noise, soil, transportation, communication, the hazards and external constraints. The positive and adverse impacts of the project during planning & designing, construction and operational phases are identified based on their duration, location, frequency, extent, significance and reversibility. Each activity impacts on various environmental parameters are given below:

Table 15: Impact Screening Checklist

Sr#	Environmental Component	Impact Characteristics												
		Duration		Location		Frequency		Extent		Significance			Reversibility	
		Long	Short	Direct	Indirect	Cont.	Intermittent	Wide	Local	Large	Moderate	Minor	Rev.	Irrev.
Beneficial Impacts														
	Employment Opportunity	<input checked="" type="checkbox"/>		<input checked="" type="checkbox"/>		<input checked="" type="checkbox"/>			<input checked="" type="checkbox"/>		<input checked="" type="checkbox"/>		<input checked="" type="checkbox"/>	
	Availability of Raw-Material	<input checked="" type="checkbox"/>		<input checked="" type="checkbox"/>		<input checked="" type="checkbox"/>			<input checked="" type="checkbox"/>		<input checked="" type="checkbox"/>		<input checked="" type="checkbox"/>	
	Appreciation in Land Value	<input checked="" type="checkbox"/>			<input checked="" type="checkbox"/>	<input checked="" type="checkbox"/>			<input checked="" type="checkbox"/>			<input checked="" type="checkbox"/>		<input checked="" type="checkbox"/>
	Energy Availability	<input checked="" type="checkbox"/>		<input checked="" type="checkbox"/>		<input checked="" type="checkbox"/>			<input checked="" type="checkbox"/>		<input checked="" type="checkbox"/>		<input checked="" type="checkbox"/>	
Adverse Impacts														
	Air Pollution		<input checked="" type="checkbox"/>	<input checked="" type="checkbox"/>			<input checked="" type="checkbox"/>		<input checked="" type="checkbox"/>			<input checked="" type="checkbox"/>	<input checked="" type="checkbox"/>	
	Wastewater		<input checked="" type="checkbox"/>	<input checked="" type="checkbox"/>		<input checked="" type="checkbox"/>			<input checked="" type="checkbox"/>			<input checked="" type="checkbox"/>		<input checked="" type="checkbox"/>
	Solid Waste and By-Products	<input checked="" type="checkbox"/>		<input checked="" type="checkbox"/>		<input checked="" type="checkbox"/>			<input checked="" type="checkbox"/>		<input checked="" type="checkbox"/>			<input checked="" type="checkbox"/>
	Health and Safety		<input checked="" type="checkbox"/>		<input checked="" type="checkbox"/>		<input checked="" type="checkbox"/>		<input checked="" type="checkbox"/>			<input checked="" type="checkbox"/>	<input checked="" type="checkbox"/>	
	Chemical Hazards		<input checked="" type="checkbox"/>	<input checked="" type="checkbox"/>		<input checked="" type="checkbox"/>			<input checked="" type="checkbox"/>		<input checked="" type="checkbox"/>		<input checked="" type="checkbox"/>	
	Physical Hazards		<input checked="" type="checkbox"/>	<input checked="" type="checkbox"/>			<input checked="" type="checkbox"/>		<input checked="" type="checkbox"/>			<input checked="" type="checkbox"/>		<input checked="" type="checkbox"/>
	Security Risks		<input checked="" type="checkbox"/>		<input checked="" type="checkbox"/>		<input checked="" type="checkbox"/>		<input checked="" type="checkbox"/>		<input checked="" type="checkbox"/>		<input checked="" type="checkbox"/>	

b) Project Impact Evaluation Matrix

The Project Impact Evaluation Matrix was developed by placing different environmental parameters that are likely to be affected by the proposed project actions, grouped into categories i.e., physical, ecological and socio-economic environment. For the impact assessment risk assessment methodology was used. Moreover, the risk assessment was done on the basis of project phases (planning & designing, construction and operation). A Project Impact Evaluation Matrix is attached as Table below:

Table 16: Impact Evaluation Matrix

Environmental Parameters	Impact Assessment during operational Phase
A: Physical	
Land Resources	
Soil Erosion and Contamination	0
Transportation	-1t
Solid Waste and By-Products	-2p
Land Use	NA
Air Resources	
Noise Pollution	-1t
Air Pollution	-2t
Dust Emissions	-1t
Water Resources	
Ground Water	-1p
Surface Water	NA
Wastewater	-2p
B : Ecological	
Flora	
Tree Cutting	+1p
Fauna	
Terrestrial Fauna	+1p
C: Socio-Economic	
Employment Opportunities	+3p
Land Value Appreciation	+2t
Availability of Local Raw-Material	+2p
Economic Uplift	+3p
D: Hazards	

Physical Hazards	-1p
Chemical Hazards	-1p
Health and Safety	-1p
<i>Legends: 1= Low; 2= Medium; 3= High; 4= Extremely High; NA= Not Applicable; t= Temporary; p= Permanent; app= Applicable; 0= Negligible</i>	

6.5 Impacts Associated with Project Location

The proponent has selected the site owing to the following reasons:

- There is no community or human settlement present on-site or in the project as the project site is located in industrial estate.
- There is no fauna or flora belonging to an endangered species present on-site
- The site has accessible through road network i.e., connected to the main road via access roads
- There is no ecologically sensitive or declared protected area like; Reserved Forest, Fish Hatcheries, Wildlife or Game Reserves. Moreover, there is no socio-cultural significant structure (historical or archaeological site or religious structures; Masjid, temples, etc.) It can be concluded in view of these reasons that the selected site is best suited for the project and will not pose any adverse impact or threat on any component of the environment.

6.6 Design Related Impacts

The negative impacts related to design of the proposed project will not be significant as the area is self-developed industrial estate having open lands in its proximity / surroundings. The machinery is according to the latest state of art technology. In view of these considerations no environmental problems are foreseen in the context of design. However, the possible impacts of proposed project have been considered and their mitigation measures proposed as under:

6.6.1 Changes in Land value

After the development of proposed project, the land value of area will enhance. It will be minor positive impact.

Mitigation

Not required.

6.6.2 Seismic Hazard

The project is situated in minor damage zone. In this zone distant earthquakes with fundamental periods greater than 1.0 second may cause damage to structures.

Mitigation

The structure of the proposed project has been designed in such a way that the building may withstand moderate to large earthquakes.

6.6.3 Emergency response

There are always chances of earthquakes and other manmade disasters such as fires due to electrical short-circuiting, over heating etc.

Mitigation

The following mitigation measures will be adopted to minimize or eliminate the emergency situations:

- The design of building will also include emergency exits, which can be used during emergency situation.
- Adequate internal and external water distribution system will be designed, which could also supply adequate quantity of water for firefighting during emergency.
- Fire hydrants and firefighting extinguishers will be provided at locations where necessary.

6.7 Impacts During Construction Stage

The potential environmental impacts of the proposed unit along with the mitigation measures during the construction stage of the project have been described as following:

6.7.1 Change in land use

The proposed project site is a vacant plot in the premises of pharmaceutical industry and the area where the project is situated, vacant plot, however industrial units are also located in the near vicinity of the project area.

Mitigation

Proposed project will not impose any major negative impact on the area in view of changes in land use because the proposed site is situated in the premises of working unit as mentioned above.

6.7.2 Impacts on Topography

The construction of the proposed project will not bring major changes in the existing topography of the project site. The changes due to the construction of the unit will be of localized nature. There will be no significant changes offsite the project area.

Mitigation

Not required.

6.7.3 Impacts on Soils

The overall geology and soil quality of the project site is not expected to be adversely impacted due to the execution of the proposed project during the construction period.

Mitigation

Plantation needs to take place at the project site so that soil becomes stabilized.

6.7.4 Impacts on Surface and Ground water

During the construction stage, the sanitary wastewater will be generated by the worker' camp(s).

Mitigation

At project site, the sanitation system already exists which will provide the safe disposal of wastewater produced from worker's camp.

6.7.5 Impacts on Air Quality

During construction phase, negligible change will occur in air quality due to the construction machinery used for the development of proposed project.

Mitigation.

No such heavy machinery will be used which has the capacity to change the air quality at project site.

6.7.6 Water Consumption

During the construction of project, a small quantity of water will be used because project is small. It will not exert any significant effect on water table.

Mitigation

Not required.

6.7.7 Health and Safety of Workers

The construction activities will impose certain negative impacts on health and safety of the workers. This impact will be minor because the construction volume is small, however mitigation measures will be required to minimize/eliminate health and safety related negative impacts of the project.

Mitigation

Implementation of the following measures will ensure health and safety of the workers during the construction stage:

- The contractor will ensure that the construction workers / laborers are trained in safety procedures for all relevant aspects of construction:
- Proponent of the Project will make regular checks to ensure that the contractor is following safety working procedures/safety measures.
- Formal emergency procedures will be developed for construction site in case of any accident. First aid kits and other necessary equipment will be kept available at site along with the list of emergency phone numbers to be contacted in case of any accident.

6.7.8 Impacts on flora

There are no trees or shrubs present at the proposed project site.

Mitigation

Not required.

6.7.9 Impacts on Fauna

The usual fauna found at the project locality of sparrows, crows, common manias etc. the project will not have any significant impacts on fauna.

Mitigation

Extensive plantation will be done at open places to enhance the beauty of the locality and project site.

6.7.10 Change of Land Appearance/layout

There would be no significant change in the land appearance, as minor execution will be involved in construction activities. The excavated earth material will be used for land filling / uplifting the floor level within the project site.

Mitigation

Not required because the project site is situated in the working unit.

6.7.11 Employment Generation

During construction stage of the proposed project, about 50+ workers/laborers will be engaged. This will be positive change.

Mitigation

Not required.

6.8 IMPACTS DURING OPERATIONAL STAGE

The anticipated environmental impacts related to the proposed Project have been studied for the operational stage as discussed below: -

6.8.1 Impacts on Climate

There will be no negative impacts expected to occur overall on climate of the area during the operational stage of the Project because the production process will be undertaken in the closed chamber machines or vessels. Generators and machinery will be maintained properly and will not impose any negative impacts on climate.

Mitigation

Not required

6.8.2 Employment Generation

When the project will be in full operation, it will generate employment for 250-300 persons. This will be a major positive impact.

6.8.3 Air Quality

During the regular operational stage of the proposed project no emissions will be generated from process however some negligible emissions from stand by generators and machinery will be produced to deal with that cyclones will be installed design and specifications are given in chapter-3.

Mitigation

Schedule of over hauling /maintenance of stand by generator/machinery will be developed.

Cyclone will also be installed at generator/machinery.

5.8.4 Noise

During the operational stage, noise will be generated only from the operation of the stand by generators and in the production hall but to the negligible level. No noisy process will be involved in the proposed project.

Mitigation

The proper foundation of the stand by generator will be constructed to cope with the problem of tremor / vibration which will consequently abate the noise problem.

- ❖ Sound proof canopy and silencer will also be installed.
- ❖ Schedule of over hauling /maintenance of stand by generator will be developed.
- ❖ Proper set back will be provided from the boundary wall, which will also help to minimize / eliminate the noise pollution.
- ❖ Extensive tree plantation along the boundary wall and at open places will also be done to act as sound barrier / sound absorber.

6.8.4 Vapor/Fumes in Production Hall

While production of the anti-biotic products some negligible fumes may be produced in the production hall. However, all the process will be undertaken in the closed chamber plan.

Mitigation

- ❖ Suction Hood will be installed in the production hall to suck the fumes if needed.
- ❖ These vapors or fugitive emissions will be captured into wet cotton filters.

6.8.5 Water Consumption

During the operational stage of the proposed project water will be used for washrooms, kitchen and process.

Mitigation

At open places the grassy lawns will be developed to recharge the water table, which will also help to control the surface runoff during rainy season. Treated wastewater will be sprinkled inside the industry premises on grassy plots.

6.8.6 Wastewater Generation

During the regular operation of the proposed project wastewater will be produced from different sources as process, kitchen or washrooms, floor washing etc.

Mitigation

- ❖ For the treatment of above mentioned, wastewater treatment plant will be installed.
- ❖ The treated wastewater will be sprinkled or used for watering of tree plantation and vegetation within the battery limits of factory.

6.8.7 Solvent Liquid Waste Generation

While operation of unit spent solvent, as liquid waste will also be generating from decontamination of mixing equipment.

Mitigation

Reuse spent solvent liquid waste from equipment decontamination as makeup in subsequent formulations.

6.8.8 Solid Waste Generation

No process solid waste or hazardous waste will be produced. Only plastic drums and packing material will be produced.

Mitigation

Packaging material and plastic drums are saleable items and will be sold to contractors and record will be maintained.

6.8.9 Health and Safety of Workers

The workers especially working in the production hall / area may be at health risk. Because they may be some exposure if they will not be properly trained and provide with Personal Protective Equipments (PPEs). This will be major negative impact if not mitigated properly.

Mitigation

To mitigate the hazards of health and safety of workers the following mitigations measures will be undertaken:

- ❖ No worker aged below 18 years or over 60 years shall be employed for any job involving physical handling of hazardous substances.
- ❖ All workers shall be thoroughly trained in safety precautions for handling hazardous substances and shall be supervised by qualified supervisors.
- ❖ Protective clothing and equipment comprising helmet of cloth cap, safety spectacles or goggles, respirators or masks, rubber or plastic gloves and workboots shall be available for all workers who may be exposed to any hazardous substances, and no worker shall be permitted on job unless and until he is wearing such protective clothing and equipment.
- ❖ To avoid any kind of potential environmental hazards the worker would be trained properly so that they know the potential hazard of chemical.
- ❖ Proper cross ventilation shall be under taken to avoid from any bad smell/odor.
- ❖ There will be proper arrangement to handle accidental / disastrous situation.
- ❖ The instructions for the workers, safety signs and precautionary / preventive measures for the costumers / visitors would be displayed at the suitable / prominent places.
- ❖ Adequate supply of water shall be made available to the workers for their personal washing as well as for washing their protective equipment's.
- ❖ Protective clothing and equipment's of the workers shall be washed and cleaned as often as required to ensure their efficiency.

- ❖ No worker shall be permitted to eat, drink or smoke till he has removed his protective clothing and equipment, washed his hands and face and left the place of work.
- ❖ All firefighting, emergency and safety equipment's shall be frequently checked and properly maintained.
- ❖ First aid medical facilities equipped with required antidotes shall be available in the premises, supervised by trained staff.
- ❖ Medical checkup of all workers shall be carried out at the time of employment and at least once a year thereafter.

6.8.10 Emergency Response

The operation of the proposed unit will handle workers and visitors who may become ill or have work related accidents. In addition, disasters such as earthquakes and fires may occur which have to be considered for minimizing their impacts.

Mitigation

- ❖ An Emergency Response Plan for earthquakes and manmade disasters will be prepared by the project management.
- ❖ Adequate supply of water shall be made available to the worker for personal washing as well as for washing their protective equipment's.
- ❖ All firefighting, emergency and Safety equipment's shall be frequently checked and properly maintained.
- ❖ Proper size and types of portable fire extinguishers will be kept near areas where flammable liquids are handled or stored.
- ❖ Adequate fire suppression system will be installed and properly functioning.
- ❖ The aesthetic conditions / outlook of the unit should be improved by tree plantation / ornamental plants and proper physical infrastructure.
- ❖ Proper disastrous and firefighting arrangements (fire extinguisher, fire hydrants, kits, instruments etc.) shall be ensured at many places of both sites.
- ❖ The internationally recognized health and safety standards will be adopted and the Emergency Response Plan will be developed and implemented in close consultation with the Fire Fighting Department.

6.9 POTENTIAL ENVIRONMENTAL ENHANCEMENT MEASURES

6.9.1 Tree Plantation

Tree plantation within and outside the premises is a potential environmental enhancement measure. A large area will be reserved for tree plantation and among plants native flora like Peepal, Kikar, Dherak, Safeeda and Amaltas will be planted in the specified green zone which will have the maximum capacity to reduce noise pollution and tolerance index of these species are more than 10. Some floral species like

roses and other ornamental evergreen plants will also be introduced in the lawn which will enhance aesthetic beauty. In addition, trees like Safeeda and Amaltas will be planted as boundary wall inside the lawn which will look like green wall. The proponent will also make arrangements for protection and maintenance of trees.

6.9.2 Facility Design

The introduction of an ecologically effective and efficient design of a facility is the environmental enhancement measures planned by the proponent to be incorporated into the design of the intended project.

6.9.3 Social Enhancement Measures

Following measures will be adopted to improve the socio-economic condition of the area:

a. Employment/Poverty Alleviation

The employment opportunities in the project area will be increased due to the establishment of proposed project at the aforesaid location. During establishment of the aforesaid facility un-skilled workers will be required as labors, sanitary workers and sweepers as well as for the skilled workers such as; accounts and managers to run the administration office local community will be considered on the priority basis. In totality, the overall economic conditions of the area will be improved due to the establishment of the aforesaid project.

b. Local Economy

The employment opportunities and/or income sources generated by the project construction and operation will be long term in nature. These will be enhanced once the construction phase is completed. The local economy will experience a slight boom during development and operational period.

7. ENVIRONMENTAL MANAGEMENT AND MONITORING PLANS

This chapter summarizes the various mitigation measures as outlined previously in this EIA Report that will be implemented during the construction, operational and decommissioning stages of project. It does not discuss further the mitigation measures which have been adopted within the design and planning of the project, as these are comprehensively covered in previous section of this EIA Report.

Outline and key features of the EMMP for operations phase is presented. As per the environmental legislation in Pakistan, the EMMP for the operations phase, along with other documents, is to be submitted to the environmental protection agency to obtain confirmation for compliance and Environmental Approval for project operation. Even after implementation of the suggested mitigation measures, the impact may remain significant, and require monitoring.

7.1 Objectives

An Environmental Monitoring Plan was outlined alongside Environmental Management Plan to ensure all the corrective actions to counter adverse impacts which gives a detailed EMMP. The EMMP will serve as a principal execution module of the project that would not only mitigate adverse environmental impacts during the construction and the operational phase of the project but also ensures that environmental standards and good in-housekeeping are being practiced. Continuous environmental monitoring is exercised to ensure that preventive measures are in place and effective to sustain environmental integrity.

The key objectives of EMMP are:

- ⊙ To outline functions and responsibilities of persons
- ⊙ To state and implement standards and guidelines which are required under environmental legislations particular in context to the Project
- ⊙ To facilitate the implementation of the mitigation measures by providing the technical details of each Project's impact and proposing implementation schedule of the proposed mitigation measures
- ⊙ Define a monitoring mechanism and identify monitoring parameters to ensure that all proposed mitigation measures are completely and effectively implemented
- ⊙ Identify the resources required to implement the EMMP and outline corresponding financing arrangements

7.2 Management Approach

The organizational roles and responsibilities of the key players are summarized below:

7.2.1 Proponent

The project proponent will undertake overall responsibility for compliance with the EMMP. The concerned departments will carry out verification checks to ensure that the contractors are effectively implementing their environmental and social requirements.

7.2.2 Contractors

The contractors will implement the majority of environmental and social mitigation measures. The contractors will carry out field activities as part of the project. The contractors are subject to certain liabilities under the environmental laws of the country, and under its contract with proponent.

7.3 Components of EMMP

The EMMP consists of the following:

- ⊙ Institutional arrangements
- ⊙ Mitigation plan to reduce the severity of associated impacts
- ⊙ Monitoring plan to monitor the impacts and their severity
- ⊙ Environmental and social trainings to raise awareness

7.3.1 Remedial and Mitigation Measures

The objective of remedial and mitigation measures in any project is to identify practices, technologies or activities that would prevent, minimize or mitigate all significant negativities that are likely to occur due to the proposed project.

7.4 Environmental Management and Monitoring Framework

The purpose of the environmental management and monitoring framework is to facilitate the implementation of environmental commitments, included in the environmental impact assessment. The proponent is committed for the protection of the environment and to the sustainable management of its related operations and activities.

Table 17: Environmental Management Plan

Sr. No.	Project Component or Impact	Target	Action	Responsibility
A- Pre-Construction / Design Related				
1	Seismic Hazard Analysis	To project the building structure from seismic hazard	<ul style="list-style-type: none"> The building will be designed to withstand moderate to large earthquakes 	Proponent / Design Consultants
2	Emergency Response	To mitigate the emergency condition	<p>The following mitigation measure will be adopted to minimize or eliminate the emergency situations:</p> <ul style="list-style-type: none"> The design of building will also include emergency exits which can be used during emergency situation. Adequate internal and external water distribution system will be designed, which could also supply adequate quantity of water for firefighting during emergency. Fire hydrants and firefighting extinguishers will be provided at locations where necessary. 	Proponent / Design Consultants
B- Construction Stage				
1	Impacts on soil	To ensure the minimum changes in soil	<ul style="list-style-type: none"> Plantation needs to take place at the project site so that soil becomes stabilized 	Contractor / Proponent
2	Impacts on surface and ground water	To mitigate the problem of contamination of surface and groundwater	<ul style="list-style-type: none"> At project site, the, sanitation system will be provided for the safe disposal of wastewater produced from workers camp. 	Contractor / Proponent

3	Health and Safety of workers and public	To ensure health and safety of workers and public	<p>Implementation of the following measures will ensure health and safety of the workers during the construction stage:</p> <ul style="list-style-type: none"> • The Contractor will ensure that the construction workers / laborers are trained in safety procedures for all relevant aspects of construction; • Proponents of the Project will make regular checks to ensure that the contractor is following safety working procedures / safety measures. • Formal emergency procedures will be developed for construction site in case of an accident. First aid kits and other necessary equipment will be kept available at site along with the list of emergency phone numbers to be contracted in case of any accident. • The safety of the public at all stages of the construction will be ensured through appropriate public education and safety measures such as use of sign boards, barriers and flags and proper illumination at night. 	Contractor / Proponent
4	Fauna	To ensure that fauna may be affected at minimum level	<ul style="list-style-type: none"> • Extensive plantation will be done at open places to enhance the beauty of the locality and project site. This will also help to protect fauna, particularly birds. 	Factory Management / Proponent
5	Disposal of Mucking Material	To avoid the degradation of soil	<ul style="list-style-type: none"> • The spoil will be carefully examined and disposed off in an environmental friendly manner by transporting it in closed containers and filling at appropriate sites. 	Contractor / Proponent

			<ul style="list-style-type: none"> It is also desirable to utilize the muck in such a way that it is consumed for the construction of any other structure within the Project Site or in the immediate vicinity. Utilization of much in the vicinity of the Project Site is considered as the best option for its disposal. 	
C- Operational Stage				
1	Air Quality	To avoid the degradation of air quality	<p>In order to minimize air pollution, following mitigation measures are recommended:</p> <ul style="list-style-type: none"> Schedule of over hauling/maintenance of stand by generator will be developed. 	Factory Management / Proponent
2	Vapors/Fumes in Production Hall	To mitigate the vapors/fumes impact in production hall	<ul style="list-style-type: none"> Suction Hood will be installed in the production hall to suck the vapors or fugitive emissions (if needed). These vapors of fugitive emissions will be captured into wet cotton filters and then these filters will be sent to lab for industrial waste incineration. 	Factory Management / Proponent
3	Noise	To mitigate the Noise problem	<ul style="list-style-type: none"> The proper foundation of the stand by generator will be constructed to cope with the problem of tremor / vibration which will consequently abate the noise problem. Sound proof canopy and silencer will also be installed. Schedule of over hauling / maintenance of stand by generator will be developed. Proper set back will be provided from the boundary wall, which will also help 	Factory Management / Proponent

			<p>to minimize / eliminate the noise pollution.</p> <ul style="list-style-type: none"> Extensive tree plantation along the boundary wall and at open places will also be done to act as sound barrier / sound absorber. 	
4	Water Consumption	To mitigate this problem	<ul style="list-style-type: none"> At open places the grassy lawns will be developed to recharge the water table, which will also help to control the surface runoff during rainy season. Treated wastewater will be sprinkled inside the mill premises on grassy plots. However, the area is industrial in nature, so the maximum rainwater will recharge the water table. 	Factory Management / Proponent
5	Solvent Liquid Waste Generation	To proper reuse the liquid solvent waste	<ul style="list-style-type: none"> Reuse spent solvent liquid waste from equipment decontamination as makeup in subsequent formulations. 	Factory Management / Proponent
6	Wastewater Generation	To mitigate the problem	<ul style="list-style-type: none"> For the treatment of above mentioned wastewater treatment plant will be installed. The treated wastewater will be sprinkled or used for watering of tree plantation and vegetation within the battery limits of factory. 	Factory Management / Proponent
7	Solid Waste Generation	To establish a proper management plan for this solid waste	<ul style="list-style-type: none"> No process solid waste or hazardous waste will be produced. The dispensary waste will be incinerated through Shalimar Hospital incinerator. 	Factory Management / Proponent

8	Health & Safety of Workers	To provide necessary health & safety facilities	<p>To mitigate the hazards of health and safety of workers the following mitigations measures will be undertaken:</p> <ul style="list-style-type: none"> • No worker aged below 18 years or over 60 years shall be employed for any job involving physical handling of hazardous substances. • All workers shall be thoroughly trained in safety precautions for handling hazardous substances and shall be supervised by qualified supervisors. • Protective clothing and equipment comprising helmet of cloth cap, safety spectacles or goggles, respirators or masks, rubber or plastic gloves and workboots shall be available for all workers who may be exposed to any hazardous substance, and no worker shall be permitted on job unless and until he is wearing such protective clothing and equipment. • To avoid any potential environmental hazards the workers would be trained properly so that they know the potential hazard of chemical. • Proper cross ventilation shall be undertaken to avoid from any bad smell/odor. 	Factory Management / Proponent
---	----------------------------	---	---	--------------------------------

			<ul style="list-style-type: none"> • There will be proper arrangement to handle accidental / disastrous situation. • The instructions for the workers, safety signs and precautionary / preventive measures for the costumers / visitors would be displayed at suitable / prominent places. • Adequate supply of water shall be made available to the workers for personal washing as well as for washing their protective equipment's. • Protective clothing and equipment of the workers shall be washed and cleaned as often as required to ensure their efficiency. • No worker shall be permitted to eat, drink or smoke till he has removed his protective clothing and equipment, washed his hands and face and left the place of work. • All firefighting, emergency and safety equipment's shall be frequently checked and properly maintained. • First aid medical facility equipped with required antidotes shall be available in the premises, supervised by trained staff. • Medical check-up of all workers shall be carried out at the time of 	
--	--	--	---	--

			employment and at least once a year thereafter.	
9	Emergency Response	To mitigate the problem of emergency situations	<ul style="list-style-type: none"> • An Emergency Response Plan for earthquakes and man-made disasters will be prepared by the project management. • Adequate supply of water shall be made available to the workers for personal washing as well as for washing their protective equipment's. • All firefighting, emergency and safety equipment's shall be frequently checked and properly maintained. • Proper size and types of portable fire extinguishers will be kept near areas where flammable liquids are handled or stored. • Adequate fire suppression system will be installed and properly functioning. • The aesthetic conditions / outlook of the unit should be improved by tree plantation / ornamental plants and proper physical infrastructure. • Proper disastrous and fire fighting arrangements (fire extinguishers, fire hydrants, kits, instruments etc.) shall be ensured at many places of both sites. • The internationally recognized health and safety standards will be adopted and the Emergency 	Factory Management / Proponent

			Response Plan will be developed and implemented in close consultation with the Fire Fighting Department, Paramedics and Civil Defense.	
--	--	--	--	--

7.4.1 Institutional Arrangements and Responsibilities

The proposed institutional arrangement for the implementation of EMMP is based on the discussions held with the Forest Department, Environmental Protection Department, Local Union Council Office and Proponent. The discussion concluded that three types of institutional arrangements are essential for the effective implementation of EMMP, these are follows:

- ⊙ Establishment of Environment/Social Management Group
- ⊙ External Monitoring by EPA certified laboratory
- ⊙ EMC established by Proponent after consultation with consultant

a) Roles and Responsibilities

Following are the designated roles and responsibilities of the employees involved in the monitoring and management of the adverse impacts:

Table 18: Roles and Responsibilities

Roles and Responsibilities		
Sr#	Concerned Persons	Duties
1	The Project Manager	<p>Following will be the responsibilities of the Project Manager</p> <ul style="list-style-type: none"> • Ensure that the contractor is aware of all specifications, legal constraints, standards and procedures pertaining to the project specifically with regards to environment. • Ensure that all stipulations within the EMMP are communicated and adhered to by contractor(s) • Monitor the implementation of the EMMP throughout the project by means of site inspections and meetings. This will be documented as part of the minutes of the site meeting documents • Ensuring project execution within defined budget and timelines • Conducting regular check of the project status and meetings with project team • Provide support and guidance to project team as and when needed • Project Manager is expected to continually monitor and improve the overall performance of their operation
4	HSE Manager	<p>In addition to the health and safety responsibilities held by staff, managers and supervisors must do whatever is reasonably practical to ensure that both the workplace and the work itself are safe. This includes:</p> <ul style="list-style-type: none"> • Ensuring that staff are appropriately trained and supervised

		<ul style="list-style-type: none"> • Identifying, assessing and managing health and safety risks • Consulting with workers (including staff, affiliates and contractors): <ul style="list-style-type: none"> iv. Health and safety risk assessments v. Decisions are made about the measures to be taken to eliminate or control these risks vi. Health and safety risk assessments • Implementing health and safety risk management programs relevant to their operations, teaching, research and consulting functions and work environment • Reporting (to the Human Resources Unit), investigating and responding to all hazards, accidents, incidents and taking action to control the risk • Assisting with the development, implementation and maintenance of a return to work program for injured staff. • Be fully conversant with the EIA and conditions of its approval • Be fully conversant with the EMMP • Be fully conversant with all relevant environmental legislation, policies and procedures, and ensure compliance • Convey the contents of this document to the contractor site staff and discuss the contents in detail with the Project Manager and Contractor • Undertake regular and comprehensive inspection of the site and surrounding areas in order to monitor compliance with the EMMP • Take appropriate action if the specifications contained in the EMMP are not followed • Monitor and verify that environmental impacts are kept to a minimum, as far as possible • Review and approve construction methods, with input from the Site Manager, where necessary • Ensure that activities on site comply with all relevant environmental legislation • Compile progress reports on regular basis, with input from the Site Manager, for submission to the Project Manager, including a final post excavation audit • Liaise with the Site Manager regarding the monitoring of the site • Report any non-compliance or remedial measures that need to be applied • All environmental problems arising on the construction area will be reported to the Site Manager by the Environmental Manager. Reports on such problems will be submitted to the Project Manager by the Site Manager
--	--	--

7.4.2 Proposed Monitoring Program to Assess Performance or Output of EMP

The following environmental issues are considered to warrant specific management actions for the implementation of project. These issues have specific regulatory requirements (contained in the

development consent or Environmental Approval) and/or are considered to have the potential to result in a non-compliance with a legislative requirement or generate community complaints. To manage the adverse environmental impacts on the physical parameters of the environment following management and monitoring plans will be adopted:

Table 19: Environmental Monitoring Plan

Aspect	Potential Impacts/ Risks	Likely Duration	Magnitude if not Mitigated	Proposed Mitigation Measures	Responsibility	Environmental Budget
A – Pre-Construction / Related						
Changes in land use	Economic gains	Permanent	Minor positive	-	-	
Seismic Hazard	Damage due to earthquake	Permanent	Moderate negative	<ul style="list-style-type: none"> The structure of the proposed project has been designed in such a way that building may withstand moderate to large earthquakes. 	Design Consultant / Proponent	
Emergency Response	There are always changes of earthquakes and other manmade disasters such as fires due to electrical short circuiting, over heating etc.	Permanent	Minor negative	<p>The following mitigation measures will be adopted to minimize or eliminate the emergency situations:</p> <ul style="list-style-type: none"> The design of building will include emergency exits, which can be used during emergency situation. Adequate internal and external water distribution system will be designed, which could also supply adequate 	Design Consultant / Proponent	50,000/-

				<p>quantity of water for firefighting during emergency.</p> <ul style="list-style-type: none"> • Fire hydrants and firefighting extinguishers will be provided at locations where necessary 		
B – Construction Stage						
Aspect	Potential Impacts/ Risks	Likely Duration	Magnitude if not Mitigated	Proposed Mitigation Measures	Responsibility	Environmental Budget
Topography	<p>The construction of the proposed project will not bring major changes in the existing topography of the project site. The changes due to the construction of the unit will be of localized nature. There will be no significant changes off-site the project area.</p>	-	-	-	-	

Impact on Soils	The overall geology and soil quality of the project site is not expected to be adversely impacted due to the execution of the proposed project during the construction period.	Temporary	Minor negative	<ul style="list-style-type: none"> Plantation needs to take place at the project site so that soil becomes stabilized. 	Contractors / Proponent	25,000/-
Impact on surface and groundwater	During the construction stage, the sanitary wastewater will be generated by the workers' camp(s).	Temporary	Moderate negative	<ul style="list-style-type: none"> At project site, the sanitation system already exists which will provide the safe disposal of wastewater produced from workers camp. The storage of lubricant materials such as oil and grease will be confined to a specific area so that in case of any leakage or spillage, the lubricant materials do not contaminate the entire project site. 	Contractors / Proponent	50,000/-
Air Quality	During the construction phase, negligible change will occur in air quality due to the construction machinery used for the	Temporary	Minor negative	No such heavy machinery will be used, which has capacity to change the air quality radically at project site	Contractor / Proponent	50,000/-

	development of proposed project.					
Health and safety of workers and public	The construction activities impose certain negative impacts on health and safety of the workers and public	Temporary	Moderate negative	<p>Implementation of the following measures will ensure health and safety of the workers during the construction stage:</p> <ul style="list-style-type: none"> the construction workers / laborers are trained in safety procedures for all relevant aspects of construction; Proponents of the project will make regular checks to ensure that the contractor is following safety working procedures/safety measure. Formal emergency procedures will be developed for construction site in case of an accident. First aid kits and other necessary equipment will be kept available at site along The contractor will ensure that With the list of emergency phone numbers to be contracted in case of any accident. 	Contractor / Proponent	30,000/-

Water Consumption	During the construction of project, the small quantity of water will be used because project is small and building is double story. It will not exert any significant effect on water table.	-	-	-	-	
Flora	There are no trees or shrubs present at the project site.	-	-	-	-	
Fauna	The usual fauna found in the project area is sparrows, crows, common manias etc. the project will be having any significant impact on fauna.	Permanent	Minor negative	<ul style="list-style-type: none"> Extensive plantation will be done at open places to protect birds and to enhance the beauty of the locality and project site. 	Proponent	25,000/-
Disposal of Mucking Material	Inevitable cut and fill earthwork operations will open up scars on the land in and around the project site. The Excavated materials that are unsuitable for use need to be stored, transported and disposed off appropriately at the designated sites.	Temporary	Moderate negative	<ul style="list-style-type: none"> The spoil will be carefully examined and disposed off in an environmental friendly manner by transporting it in closed containers and filling at appropriate sites 	Contractor / Proponent	10,000/-

Employment Generation	During construction stage of the proposed project about 55 workers / laborers will be engaged. This will be minor positive change.	-	-	-	-	
C- Operational Stage						
Aspect	Potential Impacts/ Risks	Likely Duration	Magnitude if not Mitigated	Proposed Mitigation Measures	Responsibility	
Impact on climate	There will be no negative impacts expected to occur overall on climate of the area during the operational stage of the project because the production process will be undertaken in the closed chamber machines. Generators will be kept in closed room and cyclone will be installed to control the emissions hence it will not	-	-	-	-	

	impose any negative impact on climate.					
Employment Generation	When the project will be in full operation, it will generate employment for 285 persons. This will be a major positive impact.	Permanent	Major Positive	-	-	
Air Quality	During the regular operational stage of the proposed project no emissions will be generated from process however some negligible emissions from stand by generators will be produced which will be within the PEQS because green fuel Natural gas will be used.	Permanent	Moderate negative	•	Schedule of over hauling/maintenance of stand by generator will be developed.	70,000/-
Vapor/Fumes in Production Hall	While product of the anti-biotic products some negligible fumes may be produced in the production hall. However, all the	Permanent	Negative	<ul style="list-style-type: none"> • Cyclone will be installed in the production hall if needed. • These vapors or fugitive emissions will be captured into wet cotton filters. 	Factory Management / Proponent	25,000/-

	process will be undertaken in the closed chamber machinery.					
Noise	During the operational stage, noise will be generated only from the operation of the stand by generator. No noisy process will be involved in the proposed project.	Permanent	Moderate negative	<ul style="list-style-type: none"> The proper foundation of the stand by generator will be constructed to cope with the problem of tremor / vibration which will consequently abate the noise problem. Sound proof canopy and silencer will also be installed. Schedule of over hauling/maintenance of stand by generator will be developed. Proper set back will be provided from the boundary wall, which will also help to minimize / eliminate the noise pollution. Extensive tree plantation along the boundary wall and at open places will be done to act as sound barrier / sound absorber. 	Factory Management / Proponent	25,00 0/-
Water Consumption	During the operational stage of the proposed project about water	Permanent	Negative	•	At open places the grassy lawns will be	

	will be used for washrooms, kitchen and process.				developed to recharge the water table, which will also help to control the surface runoff during rainy season.	
Wastewater Generation	During the regular operation of the proposed project about wastewater will be produced from different sources as process, kitchen or washrooms, floor washing etc	Permanent	Major negative	<p>The following mitigation measures will be adopted:</p> <ul style="list-style-type: none"> • For the treatment of the above-mentioned wastewater treatment plant will be installed. • The treated wastewater will be sprinkled or used for watering of tree plantation and vegetation within the battery limits of factory. • The surplus treated wastewater will be drained out into the main Drain. 	Factory management / Proponent	0/- 70,00

Solvent Liquid Waste Generation	<ul style="list-style-type: none"> While operation of the unit spent solvent As liquid waste will also be generating from decontamination of mixing equipment. 	Permanent	Major negative	<ul style="list-style-type: none"> Reuse spent solvent liquid waste from equipment Decontamination as makeup in subsequent formulations. 	Factory Management /Proponent	20,000/-
Solid Waste Generation	<p>No process solid waste or hazardous waste is will be produced.</p> <p>Only plastic drums and packaging material will be produced. The dispensary waste will be incinerated thought Shalimar Hospital incinerator.</p>	Permanent	Moderate negative	No process solid waste or hazardous waste will be produced from proposed unit.	Factory Management / Proponent	30,000/-
Health & Safety of Workers	The workers especially working in the production hall / area may be at health risk. Because they	Permanent	Major Negative	To mitigate the hazards of health and safety of workers the following mitigations measures will be undertaken:		

	<p>may be some exposure if they will not be properly trained and provide with Personal Protective Equipment's (PPEs). This will be major negative impact if not mitigated properly.</p>			<p>No worker aged below 18 years or over 60 years shall be employed for any job involving physical handling of hazardous substances.</p> <ul style="list-style-type: none"> • All workers shall be thoroughly trained in safety precautions for handling hazardous substances and shall be supervised by qualified supervisors. • Projective clothing and equipment comprising helmet of the cloth cap, safety spectacles or goggles, respirators or masks, rubber or plastic gloves and Workboots shall be available for all workers who may be exposed to any hazardous substance, and no worker shall be permitted on job unless and until he is wearing such protective clothing and equipment. 		<p>50,000/-</p>
--	---	--	--	---	--	-----------------

				<ul style="list-style-type: none"> To avoid any potential environmental hazards the workers would be trained properly so that they know potential hazard of chemical. Proper cross ventilation shall be undertaken to avoid from any bad smell / odor. First aid medical facility equipped with required antidotes shall be available in the premises, supervised by trained staff. Medical check-up of all workers shall be carried out at the time of employment and at least once a year thereafter. 		
Emergency Response	The operation of the proposed unit will involve workers and visitors who may become ill or have work related accidents. In addition, disasters	Permanent	Major negative	<ul style="list-style-type: none"> An Emergency Response Plan for earthquakes and manmade disasters will be prepared by the project Management. 	Factory Management / Proponent	

	<p>such as earthquakes and fires may occur which have to be considered for minimizing their impacts.</p>			<ul style="list-style-type: none"> • Adequate supply of water shall be made available to the workers for personal washing as well as for washing their projective equipment's. • All firefighting, emergency and safety equipment's shall be frequently checked and properly maintained. Proper size and types of portable fire extinguishers will be kept near areas where flammable liquids are handled or stored. • Adequate fire suppression system will be installed and properly functioning. • The aesthetic conditions / outlook of the unit should be improved by tree plantation / ornamental plants and proper physical infrastructure. 		<p>30,000/-</p>
--	--	--	--	---	--	-----------------

				<ul style="list-style-type: none">• Proper disastrous and firefighting arrangements (fire extinguishers, fire hydrants, kits, entrustments etc.) shall be ensured at many places of both sites.• The internationally recognized health and safety standards will be adopted and the Emergency Response Plan will be developed and implemented in close consultation with the Fire Fighting Department, Paramedics and Civil Defense.		
--	--	--	--	---	--	--

7.5 Proposed EMP Reporting and Reviewing Procedures

An effective mechanism to store and communicate environmental information during the project is an essential requirement of an EMP.

7.5.1 Meetings

As environment is multidisciplinary subject with environmentalist having a dynamic role therefore Environment Officer would be considered as integral part in both constructional and operational team. Participation of Environment Officer in daily morning meeting and any other special meeting is mandatory. Besides internal meeting HSE Engineer/Environment Officer is also responsible to conduct meeting with local in keeping administration in liaison.

7.5.2 Changes-Record Register

A change-record register will be maintained at the site, in order to document any changes in project design. These changes will be handled through the change management mechanism.

7.6 Impacts and their Mitigation Summary

Environmental and social impacts have been identified for the process of pharmaceutical plant; their impacts had been mitigation by adopting required measures as recommended in EMMP of this EIA Report within the Project Area of Influence. The major impacts on physical, biological and social environment are described as under:

Table 20: Impacts Summary of Pharmaceutical Industry Processing

Environmental Parameters	Impact Assessment during operational Phase	
	Operational	
A: Physical		
Land Resources		
Soil Erosion and Contamination	0	
Transportation	-1t	
Solid Waste and By-Products	-2p	
Land Use	NA	
Air Resources		
Noise Pollution	-1t	
Air Pollution	-1t	
Dust Emissions	-1t	
Water Resources		
Ground Water	-1p	
Surface Water	NA	
Wastewater	-2p	

B : Ecological	
Flora	
Tree Cutting	+1p
Fauna	
Terrestrial Fauna	+1p
C: Socio-Economic	
Employment Opportunities	+3p
Land Value Appreciation	+2t
Availability of Local Raw-Material	+2p
Economic Uplift	+3p
D: Hazards	
Physical Hazards	-1p
Chemical Hazards	-1p
Health and Safety	-1p
<i>Legends: 1= Low; 2= Medium; 3= High; 4= Extremely High; NA= Not Applicable; t= Temporary; p= Permanent; app= Applicable; 0= Negligible</i>	

7.7 Equipment Maintenance Details

The Client and Contractor will be responsible to maintain equipment with higher efficiency and in good working conditions. The equipment will be maintained twice a year as well as monthly inspection will be done on the regular basis to keep the process going without any interruption.

7.8 Environmental Budget

The environmental budget for the project is PKR 5 lacs which will be used for the control of the air pollution by the installation of dust collection system, tree plantation at various designated sites, EMMP for the operational phase and monitoring of environmental parameters (such as ambient air, noise and wastewater). The total cost of the project is PKR 6.7 million. EMMP and the monitoring will be carried out on the regular basis. So, more than 1% of the total project cost will be allocated for the environmental protection.

8. CONCLUSION AND RECOMMENDATIONS

The findings of EIA Report showed that although the establishment of pharmaceutical plant is expected to have significant negative impacts on the environment during the construction and operational phases, but the severity of these adverse impacts can be reduced significantly by adopting the suggested mitigation measures in EMMP with true spirit. Moreover, their severity can be further reduced by adopting relative mitigation measures as proposed in the Chapter 7 of this EIA Report. The impacts were assessed by frequent site visits, studying related projects and by reviewing relevant documents. Generally, the project is planned to follow efficient environmental management systems. Specific environmental and social benefits have been mentioned below which depend on the proper application of mitigation measures suggested in EMMP and best engineering practices.

8.1 Merits and Demerits

The major positive impacts include;

- ⊙ **Increased job opportunities,**
- ⊙ **Business opportunities,**
- ⊙ **Availability to the locals.**
- ⊙ **Environmental enhancement through tree planation.**

The project will raise the income of the persons directly associated with project as well as it will also improve the socio-economic status of the area. The project is expected to stimulate the local economies of the community as the majority of the people living in the nearby areas are associated with the labor related activities.

In general, potential adverse environmental effects resulting from the proposed activities will be temporary in nature, short-term and of low magnitude. Through application of standards, recommended mitigation measures, adherence to applicable permit conditions and regulations, adverse impacts can be effectively minimized. The project is not likely to have significant adverse environmental impacts which cannot be mitigated. Negligible negative impacts that are likely occur during pharmaceutical plant processing includes; air pollution due to movements of vehicles, removal of bushes and shrubs, potential impact to the local water resources and social impacts may affect the locals residing in the nearby community can be foreseen. Mitigation measures will be implemented to minimize environmental impacts though they are still negligible. There are certain mitigations suggested to cater for the aforesaid issues.

8.2 Recommendations

The intensity and severity of impacts occurred due to the pharmaceutical plant processing varies with change in the nature and magnitude of the project as well as depends upon the baseline environmental conditions of the area. The mitigation measures will require constant information flow and consultation with the stakeholders to ensure the least adverse social-economic impact to outweigh the “no project development” scenario.

- ☑ The adverse environmental impacts can be reduced significantly by adopting best management and monitoring practices as well as by implementation EMMP with true spirit
- ☑ Proper PPEs including aprons, rubber gloves and shoes should be provided to workers
- ☑ No compromise on public health and environment should be allowed.
- ☑ Waste minimization practices should be introduced to workers by conducting lectures on spot to aware the workers about the long-term benefits of the same in lieu of surrounding environment.
- ☑ A proper tree plantation plan should also be developed in order to make the process environment friendly.
- ☑ Small domestic waste storage bins should be placed at different locations for proper collection and disposal of the solid waste.
- ☑ It is recommended that the Proponent should obtain an Environmental Approval (NOC) from the Punjab-EPA before proceeding further.

GLOSSARY

Aesthetic	Concerned with beauty or appreciation of beauty.
Agency	A business or organization providing a particular service on behalf of another business, person, or group.
Cephalosporins	The cephalosporins are a class of β -lactam antibiotics originally derived from the fungus Acremonium
Climate	The weather conditions prevailing in an area in general or over a long period.
Consultant	A person who provides professional advice or services to companies for fee.
Construction Waste	Waste generated from the buildings and construction industry and includes material like bricks, concrete, tiles, debris, ceramics and more.
Convention	An agreement between states covering particular matters, especially one less formal than a treaty.
Demographic	A single vital or social statistic of a human population, as the number of births or deaths.
Ecology	The branch of biology that deals with the relations of organisms to one another and to their physical surroundings.
Endangered species	A species of animal or plant that is seriously at risk of extinction.
Environment	Relationship of natural world (human beings, animals and plants) with physical surroundings (air, land, water).
Excavation	Excavation is the act or process of digging, especially when something specific is being removed from the ground. Archaeologists use excavation to find artifacts and fossils.
Framework	A framework is a real or conceptual structure intended to serve as a support or guide for the building of something that expands the structure into something useful.
Hazardous Waste	Hazardous Waste is waste that poses substantial or potential threats to public health or environment.
Livelihood	A set of activities involving Securing the basic necessities –food, water, shelter and clothing of life.
Municipal Waste	Municipal Solid Waste (MSW)—more commonly known as trash or garbage—consists of everyday items we use and then throw away,

	such as product packaging, grass clippings, furniture, clothing, bottles, food scraps, newspapers, appliances, paint, and batteries. This comes from our homes, schools, hospitals, and businesses.
Nature	The phenomena of the physical world collectively, including plants, animals, the landscape, and other features and products of the earth, as opposed to humans or human creations.
Penicillin's	The term "penicillin" is defined as the natural product of Penicillium mould with antimicrobial activity.
Pharmaceutical Industry	The pharmaceutical industry is the part of the healthcare sector that deals with medications
Preservation	Preservation is the strict setting aside of natural resources to prevent the use or contact by humans or by human intervention. In terms of policy making this often means setting aside areas as nature reserves (otherwise known as wildlife reserves), parks, or other conservation areas.
Proponent	A person who advocates a theory, proposal, or course of action.
Rehabilitation	To restore to a condition of good health, ability to work, or the like.
Resettlement	The settlement of people in a different place.
Resource	A stock or supply of money, materials, staff, and other assets that can be drawn on by a person or organization in order to function effectively.
Sanitation	Conditions relating to public health, especially the provision of clean drinking water and adequate sewage disposal.
Stakeholder	A stakeholder is a party that has an interest in a company and can either affect or be affected by the business. The primary stakeholders in a typical corporation are its investors, employees and customers.
Topography	Topography is the study of the shape and features of the surface of the Earth and other observable astronomical objects including planets, moons, and asteroids.
Vegetation	Plants considered collectively, especially those found in a particular area or habitat.

LIST OF ABBREVIATIONS

ABBREVIATION	DESCRIPTION
ASR	Air Sensitive Receivers
BDL	Below Detection Limit
BOD	Bio-chemical Oxygen Demand
CC	Construction Contractor
CDM	Clean Development Mechanism
CO	Carbon Monoxide
COD	Chemical Oxygen Demand
DCO	District Co-ordination Officer
DD	Deputy Director
DG	Directorate General
DRR	Disaster Risk Reduction
DWQS	Drinking Water Quality Standards
EE	Environmental Engineer
EIA	Environmental Impact Assessment
EMMP Plan	Environmental Management and Monitoring
EPA	Environment Protection Agency
EPC	Engineering Procurement Construction
EPD	Environment Protection Department
EPHE	Environmental & Public Health Engineering
FGDs	Focused Group Discussion
GDP	Gross Domestic Product
gm	Gram
GoP	Government of Pakistan
IEE	Initial Environmental Examination
LGO	Local Government Ordinance
LDL	Lowest Detection Limit
mg/l	Milligrams per liter
MSL	Mean Sea Level
NCS	National Conservation Strategy

NEQS	National Environmental Quality Standards
NEP	National Environmental Policy
NO2	Nitrogen Dioxide
NOC	No Objection Certificate
OH & S	Occupational Health and Safety
PAPs	Project Affected Persons
PEPA	Pakistan Environmental Protection Act
PEPC	Pakistan Environmental Protection Council
PEQS	Punjab Environmental Quality Standards
PM	Particulate Matter
SO2	Sulfur Dioxide
SOP	Standard Operating Procedures
SWM	Solid Waste Management
TA	Technical Assistance
TORs	Terms of Reference
TSS	Total Suspended Solids
UNDP	United Nation Development Pro
WASA	Water and Sanitation Agency

LIST OF PEOPLE CONSULTED AND THEIR VIEWS

SR. NO.	NAME	ID CARD NUMBER	OCCUPATION	CONCERN/VIEWS
1.	Ghulam Shabir	36303-7360882-5	farmer	Positive
2.	Ansar Ali	34101-5615463-9	Farmer	Positive
3.	Liaqat Ali	34101-527.5075-1	Farmer	Positive
4.	Abdul Rehman	34102-0434594-7	Shop Owner	Concerned about air pollution
5.	Muhammad Bilal	36303-9299987-3	Shop Owner	Concerned about Noise pollution
6.	Muhammad Yousaf	36302-5965175-3	Daily Wager	Positive
7.	Muhammad Asif	36303-4107290-1	Daily Wager	Positive
8.	Muhammad Iqbal	36303-1561962-1	Vendor	Positive
9.	Abdul Hameed	36302-0474840-7	Vendor	Positive
10.	Muhammad Imran	42201-3691562-7	Daily Wager	Positive
11.	Muhammad Sabir	36303-9221124-3	Vendor	Concerned noise pollution
12.	Muhammad Shahid	36306-4248907-7	School Teacher	Wastewater should be properly treated prior to final disposal in nearby drain
13.	Sohail Ahmad	35304-8398428-1	Field Officer Horticulture department	Plantation should be carried out at extensive scale

Sources of Data

- ✚ <https://www.pmd.gov.pk/en/>
- ✚ <https://www.pbs.gov.pk/>
- ✚ <http://www.weather-and-climate.com/>
- ✚ <https://www.investmentbank.com/pharma-industry-overview/>
- ✚ <https://www.ppma.org.pk/Profile/pakistan-pharmaceutical-industry/>
- ✚ Lakdawalla, D. N. (2018). Economics of the pharmaceutical industry. *Journal of Economic Literature*, 56(2), 397-449.
- ✚ Tauqeer, F., Myhr, K., & Gopinathan, U. (2019). Institutional barriers and enablers to implementing and complying with internationally accepted quality standards in the local pharmaceutical industry of Pakistan: a qualitative study. *Health policy and planning*, 34(6), 440-449.
- ✚ Bhatti, S. H., Vorobyev, D., Zakariya, R., & Christofi, M. (2020). Social capital, knowledge sharing, work meaningfulness and creativity: evidence from the Pakistani pharmaceutical industry. *Journal of Intellectual Capital*.
- ✚ Field Surveys
- ✚ Public Consultations

TERMS OF REFERENCE (TORS)

The consultant is required to carry out an initial environmental examination study of the project under Section-12 of Pakistan Environmental Protection Act 1997/ Punjab Environmental Protection (Amendment) Act 2012.

The Study should be comprehensive and should cover all aspects which are envisaged under the relevant national and provincial laws & regulations including but not limited to:

- Identification and recommendation for suitable solution/treatment/mitigation measures for emissions and effluents such as wastewater and sludge etc. in accordance with Punjab Environmental Quality Standards (PEQS).
- Identification and recommendation for suitable solution/treatment/mitigation measures of solvents, oils (tar), hazardous waste, organic compounds, steam, flue gases, particulate matter and chemical compounds harmful for the environment and other substances leading to air, noise, water and soil pollution in accordance with PEQS.

The Study should be acceptable to the relevant national and/or provincial authorities (relevant authorities) in Punjab.

PROJECT TEAM AND RESPONSIBILITIES

Name of expert	Position held	Highest Qualification	TERM OF REFERENCES
Kamal Ahmed Cheema	Chief Environmentalist	M. Phil. Environmental Economics, PIDE, Islamabad	Mr. Kamal would be responsible for: <ul style="list-style-type: none"> ❖ Environmental Assessment & Management. ❖ Supervision of monitoring team for air water noise and soil analysis. ❖ Preparation of technical EMP
Mr. Shahzaib Ahmed	Social Scientist	M. Phil Development Studies, PIDE, Islamabad.	Mr. Shahzaib would be responsible for: <ul style="list-style-type: none"> ❖ Detailed social survey of project sites ❖ Social impact assessment
Arslan Iqbal	Environmentalist-2	MPhil Environmental Sciences, UOL	Mr. Arslan would be responsible for: <ul style="list-style-type: none"> ❖ Biodiversity assessment ❖ Detailed flora fauna survey of project sites ❖ Identification of threaten and endangered species ❖ Project impacts on flora and fauna ❖ Detailed social survey of project sites ❖ Social impact assessment ❖ Consultation with stakeholders
Amna Hafeez	Environmentalist-3	M.Sc Mountain Conservation and Watershed Management, University of the Punjab	Ms. Amna would be responsible for: <ul style="list-style-type: none"> ❖ Report writing ❖ Field surveys and consultation with stakeholders ❖ Preparation of Environment monitoring plan ❖ Preparation of technical EMP ❖ Identification of sensitive receptors ❖ Capacity building & training ❖ Conducting and monitoring of health assessment surveys ❖ Environment health risk assessment and management ❖ Detailed survey of project sites ❖ Environmental Assessment ❖ Social Assessment
Rahma Butt	Environmentalist-4	BS (Hons) Environmental Science, Lahore College for Women University.	Ms. Rahma would be responsible for: <ul style="list-style-type: none"> ❖ Detailed flora and fauna survey of project sites ❖ Site Monitoring

			<ul style="list-style-type: none"> ❖ Socio-Economic survey & analysis ❖ Report Writing
Zeshan Ahmad	Environmental Executive Officer	BS Environmental Sciences	Mr. Zeshan would be responsible for: <ul style="list-style-type: none"> ❖ Biodiversity assessment ❖ Detailed flora fauna survey of project sites ❖ Identification of threaten and endangered species ❖ Detailed social survey of project sites ❖ Social impact assessment ❖ Consultation with stakeholders ❖ Site Monitoring
Muhammad Atif	Environmental Executive Officer	M.phil Environmental Sciences	Mr. Atif would be responsible for: <ul style="list-style-type: none"> ❖ Site Monitoring ❖ Socio-Economic survey & analysis ❖ Risk Assessment (OHS & EMP)