

EXECUTIVE SUMMARY

1. Introduction

This executive summary presents an overview of the main findings of the Environmental Impact Assessment Report for Construction of Marhaba LPG Traders (PVT) Limited (LPG Storage & Filling Plant) At Mouza Dhenga, Tehsil Ferozewala and District Sheikhupura. The main goal of the Proposed Project is to provide a safe, economic and environment friendly LPG. For this instance, Environmental Impact Assessment of the Project has been conducted in accordance with the Punjab Environmental Protection (Amendment) Act, 2012 and IEE/EIA Regulations 2022. The process for conducting environmental assessment and the results of EIA is described in this document.

Table 1: Salient Features of Project

1.	Project Title	Marhaba LPG Traders (PVT) Limited
2.	Project Location	Mouza Dhenga, Tehsil Ferozewala and District Sheikhupura.
3.	Proponent	Muhammad Asif Javed S/O Muhammad Yousaf. P.O. Batapur, Umar Khan Road, Manawan Tehsil Shalimar District Lahore.
4.	Consultant	EnvironTech Consultants (PVT) Ltd.
5.	Total Area	24 kanal
6.	Capacity of Project	Storage Capacity of 100 MT with two tanks of capacity 50 MT each. Filling capacity Will be 25 MT/Day
7.	Location of project	31°36'34.4"N 74°08'17.4"E
8.	Nature of Area	Self-developed commercial
9.	Present status of Land Use	Open Plot
10.	Land use in the surroundings of project site.	The project site is surroundings by:
	North	Road
	East	Open land
	West	Open Land
	South	Open land
11.	Cost of Project	PKR 70 million PKR
12.	Product	LPG Storage & filling
13.	By-Products	N/A
14.	Description of proposed project	The proposed project is the establishment of LPG Storage & Filling Plant.

15.	Nearby emergency services i.e., Hospital, police station, rescue, fire brigade etc.	Hospital (0.4 Km), Rescue 1122 office (3.6 Km), Police Station (2.8 Km).
16.	Water Source	Ground Water
17.	Status of Project	Open Land
18.	Source of Power	WAPDA (GEPCO)

2. Project Objectives

The main objectives of this EIA are to establish baseline environmental conditions, identify potential impacts and suggest suitable mitigation measures for the execution of the proposed project. This study has been accomplished in line with the prescribed legal provisions of guidelines and directives of the Punjab Environmental Protection Agency.

The overall aim of the Proposed Project is to provide a safe, economic and environment friendly storage of LPG for LPG suppliers and direct consumers.

This executive summary presents an overview of the main findings of the EIA Report for the aforesaid project.

3. BENEFITS OF PROPOSED PROJECT

The proposed project shall yield following benefits:

- ✚ Maintain continuity in supply of LPG to the consumers through distributors and quality of services to the consumers.
- ✚ Ease in availability of filled LPG during crisis period.
- ✚ Help to overcome the scarcity of bulk LPG due to huge gap between demand and supply.
- ✚ Discourage deforestation with reduction in use of firewood and fossil fuels.

4. SITE ALTERNATIVES

An Open land acquired by the proponent is selected for the Construction of LPG plant. Selected site is an unproductive land and is going to be brought into commercial use which will be beneficial for the locals as they will get jobs. The site is well located in regard to the following:

- ✚ Easy road access to the market
- ✚ No settlements at a safe distance
- ✚ No watercourse within a safe distance
- ✚ No ecologically sensitive or declared protected area within 10 km of the selected site

5. SCREENING

As per PEPA 2012, the Initial Environmental Examination (IEE)/ Environmental Impact Assessment (EIA) Regulations, 2022 the Proposed Project falls in A (5) category of projects mentioned in Schedule II.

6. Major Impacts and Recommended Mitigation Measures

a. Beneficial/Positive Impacts:

- ✚ Maintain continuity in supply of LPG to the consumers through distributors and quality of services to the consumers.
- ✚ Ease in availability of filled LPG during crisis period.
- ✚ Discourage deforestation with reduction in use of firewood and fossil fuels.
- ✚ Provision of employment and stimulation of local economy.
- ✚ Enhancement of community development through implementation of corporate social responsibilities.
- ✚ Help to overcome the scarcity of bulk LPG due to huge gap between demand and supply.
- ✚ Positive changes in lifestyles will occur due to reduce in expenses of transportation for refilling.

b. Negative Impacts:

Environmental Parameters	Recommended Mitigation
A: Physical	
Effect on Geomorphology and Soil	<ul style="list-style-type: none"> • Spill Prevention and Response Plan for storage, use and transfer of fuel and hazardous materials should be prepared. • Workers should be trained on spill prevention and response plan. • Thick Plantation is recommended after completion of project to minimize land slippage and soil erosion impacts. • Fuels, lubricants, and chemicals should be stored in covered areas, underlain with impervious lining. • Maintenance and washing of vehicles and equipment should be carried out at designated areas. • Any hard surface or tarpaulin should be spread on area to prevent soil contamination. • Regular inspections should be carried out to detect leakages in construction vehicles and equipment. • Appropriate arrangements, including shovels, plastic bags and absorbent materials, should be available near fuel storage areas.
Water Quality	<ul style="list-style-type: none"> • Lined Septic tanks will be provided • Fuels and lubricants will be stored in areas with impervious floors • Proper drainage will be provided to construction camp and construction site.
Dust Emissions	<ul style="list-style-type: none"> • The most effective means of reducing the dust emission is wet suppression. Watering exposed surfaces and soil with adequate frequency to keep soil moist at all times can reduce the total dust emission from the project by as much as 75% • Dust emission from soil piles and aggregate storage stockpiles will be reduced by covering the piles, for example with tarpaulin or thick plastic sheet. • Good quality (low sulfur) fuel will be used for vehicle and machinery • Construction materials that are susceptible to dust formation will be transported only in securely covered trucks to prevent dust emission during transportation. • Provision of dust respirators to equipment operators who are exposed to dust while operating their equipment. • Tree planting on open and disturbed areas which will not be used by the operations.

Noise	<ul style="list-style-type: none"> • Reduce equipment noise at source by proper design, maintenance and repair of construction machinery and equipment. • Minimize noise from vehicles by use of proper silencers and mufflers. • Use noise-abating devices wherever needed and practicable. • The movement of vehicle should be restricted during nighttime. • Providing workers with noise related PPE's • Planting of trees that could serve as sound buffers. • Hauling trucks shall be operated at low speed to minimize vibration, promote road safety, etc.
Water Quality	<ul style="list-style-type: none"> • Minimize the land disturbance as much as possible. • Proper storage techniques will be adopted to avoid leakage and to prevent the erosion of soils. • Existing drainage systems will not be altered. • Maintenance and fueling of the vehicles will be done at designated places (not at site) • Earthy materials and runoff will be handled in a manner that prevents adding suspended solids to flowing water which will prevents water pollution
B: Ecological	
Terrestrial Flora	<ul style="list-style-type: none"> • As such there is not any thick natural vegetation on the project site. So, there is no possibility of vegetation loss. But Proponent has planned a Tree Plantation. • Buffer zones will be provided to the agricultural fields.
Terrestrial Fauna	<ul style="list-style-type: none"> • Wildlife protection and biodiversity management plan should be enforced in the case of disturbance to the wildlife present in the project area. • Labourers will not be allowed to discard food, plastic etc. which can attract animals/birds near the core site
C: Socio-Economics	
Health Deterioration	<ul style="list-style-type: none"> • Occupational Health and Safety SOPs will be enforced • Personal Protective Equipment (PPEs) should be given to the workers • Wearing of the PPEs should be regulated strictly by the concerned authority • Exist route should be demarcated clearly • First aid kits should be present on-site to treat minor injuries • Routine medical check-ups of the labor should be done on the regular basis • Ambulance and related equipment should be made available immediately in the case of emergency and in the case of the disaster
Safety	<ul style="list-style-type: none"> • A stop sign will be put up on the access road. • A speed breaker will be constructed on the access road. • The speed limit for the access road will be kept low. • A public safety plan should be developed and displayed. • Community complaints register, and other mean should be adopted for the community to complain. • All entry points into the construction area should be staffed 24 hour a day. People who are not related to the project should not be allowed inside. • No machinery should be left unattended, particularly in the running condition. • Nighttime driving of project vehicles should be limited. • Drivers will be trained to drive slowly following traffic rules.

5. Environmental and Social Monitoring Plan

Environmental Management and Monitoring Plan (EMMP) were developed for effective implementation of the recommended mitigation measures. The EMMP includes check and balance to control and

minimize the identified impacts and monitoring programs to oversee residual impacts, if any, during the operational phase. The EMMP describes procedures to be followed throughout the operation of the project. It also identifies the roles and responsibilities of all concerned personnel, including the persons reporting during the different project phases. Mitigations for physical, biological and socio-economic parameters will be measured to determine compliance with standards established in EMMP. The Monitoring Plan will record the inputs provided by various participants in the environmental and social management process. It will also check whether the prescribed national and provincial guidelines and plans are being followed and that the required mitigation measures and activities are being accomplished in time.

6. Monitoring Plans

During operational phase, monitoring is required to be carried out at least once in a month during rainy season to check the soil contamination and surface water level/condition. Moreover, periodic monitoring should also be carried out regarding ambient air quality, noise and dust level and worker safety. A detailed site monitoring plan has been developed and given in Chapter-6 of this EIA Report.

7. Conclusion

The Environmental Impact Assessment contains description of the project, description of the environmental baselines, potential environmental impacts and suggested mitigation measures. An implementation mechanism for mitigation measures in the form of an Environmental Management Plan is included in the study. While the objectives of this study have been to describe the project and its environmental impact, it also identifies adverse environmental factors associated with the project. Appropriate mitigation measures as explained in the environmental study should reduce, if not eliminate, these impacts so that these are within acceptable limits. It is further concluded that all potential environmental concerns associated with the project have been adequately addressed, and no further study is required in this context. The objective of preparation of an environmental study is to identify how the environment is impacted and to suggest mitigating measures to reduce if not totally eliminate adverse effects of a project. It is accordingly recommended that Environmental Approval for the project should be issued by the Punjab Environmental Protection Agency, subject to payment of the requisite scrutiny fee by the proponents of the project. The adverse environmental impacts can be reduced significantly by adopting best management and monitoring practices as well as by implementation EMMP with true spirit.

Table of Contents

1	CHAPTER 1. INTRODUCTION	13
1.1	General	13
1.1.1	Screening	13
1.2	Purpose of study	13
1.3	The Proponent	14
1.4	Details of Consultant	14
1.4.1	Team Members	15
1.5	Brief Description of Nature, Size, And Location of Project	15
1.5.1	Nature of Project	15
1.5.2	Size of Project	15
1.5.3	Location of Project	15
2	Chapter 2. Screening and Scoping	16
2.1	Screening/Type and Category of Project	16
2.2	Scoping:	16
2.3	Alternatives	17
2.3.1	Technology Alternative	17
2.3.2	Site Alternatives	18
2.3.3	<i>Environmental Alternatives:</i>	18
2.3.4	<i>Economic Alternatives:</i>	18
3	CHAPTER 3. PROJECT DESCRIPTION	19
3.1	Screening/Type and Category of Project	19
3.2	Objectives of Project	19
3.3	Location and Layout of Project	19
3.4	Land Use on Site	20
3.5	Road Access	20
3.6	Vegetative Features	21
3.7	Cost and Magnitude of Operation	21
3.8	Schedule of implementation	21
3.9	Project Description	21
3.9.1	Raw Materials	21
3.9.2	Final Product	21
3.9.3	Capacity	22
3.9.4	Plant Utilities and Machinery	22
3.10	Fire Copping System	22
3.10	PROCESS DESCRIPTION	23
3.11.1	Filling of Storage Tanks	23
3.11.2	Transfer of LPG to Filling Station	23
3.11.3	Visual Inspection / Segregation of Cylinders	24
3.11.4	Final Inspection	24
3.11	SUPPLIES	24

3.12.1	Water Supply	24
3.12.2	Fire-Fighting System& Emergency Response Plan.....	24
3.12.3	Electricity	24
3.12.4	Manpower.....	24
3.12.5	Health, Safety & Hygiene	24
3.12.6	First Aid facility	24
3.12.7	Safety Trainings.....	25
3.12.8	Use of Drugs and Narcotics.....	25
3.12	Leakage Detection System:	25
3.13	Personal Protective Equipment	25
3.14	Wastewater Source and Treatment.....	26
3.15	Air Emissions Source and Treatment.....	26
3.16	Noise Source and Treatment	27
3.17	Solid Waste Source and Treatment	27
3.18	Relocation and Rehabilitation Plans.....	27
3.19	Land ownership Documents.....	27
3.20	Government Approvals.....	27
4	CHAPTER 4. DESCRIPTION OF THE ENVIRONMENT	28
4.1	Methodology	28
4.1.1	<i>Data Collection</i>	28
4.1.2	<i>Social Survey</i>	28
4.1.3	<i>Sampling Design</i>	28
4.1.4	<i>Questionnaires</i>	28
4.1.5	<i>Data Editing and Analysis</i>	29
4.2	Review of Legal and Administrative Framework	29
4.3	Baseline Conditions	29
4.4	Physical Environment.....	29
4.4.1	<i>Topography</i>	29
4.4.2	<i>Hydrology</i>	30
4.4.3	<i>Seismicity</i>	30
4.4.4	<i>Climate</i>	30
4.4.5	<i>Wind</i>	32
4.5	Ecological Environment	33
4.5.1	<i>Aquatic Flora & Fauna</i>	33
4.5.2	<i>Flora</i>	33
4.8.3	<i>Fauna</i>	34
4.8.6	<i>Water Resource</i>	35
4.9	Socio-Economic Resources	36
4.10	Socio-Economic Profile of Study Area.....	36
4.11	Demographic Profile	36
4.11.1	<i>Health Facilities</i>	36

4.11.2	<i>Educational Facilities</i>	36
4.11.4	<i>Demographic Characteristics of the Population</i>	36
4.11.5	<i>Family Size</i>	37
4.11.6	<i>Age Groups</i>	37
4.11.7	<i>Occupation of Respondents</i>	37
4.11.8	<i>Literacy Rate</i>	38
4.11.9	<i>Common Diseases</i>	38
4.11.10	<i>Cultural, Religious & Other Structures</i>	38
4.12	Lab Reports of Environmental Analysis	38
4.13	Suitability of Site:	38
5	Chapter 5. IMPACT ASSESSMENT METHODOLOGY	39
5.1	Objectives	39
5.2	Methodology	39
5.2.1	Magnitude	39
5.2.2	Immediacy	39
5.2.3	Sustainability and Reversibility	39
5.3	Purpose of Mitigation Measure	40
5.3.1	What is the problem?	40
5.3.2	When problem will occur and when it should be addressed?	40
5.3.3	Where problem should be addressed?	40
5.3.4	How the problem should be addressed?	40
5.3.5	Ways of Achieving Mitigation Measures?	40
5.3.6	Changing in Planning Design	40
5.4	Improved Management and Monitoring Practices	40
5.5	Impact Assessment Methodology	41
5.6.1	Screening of Potential Impacts	41
5.6.2	Identification of Mitigation Measures	41
5.6.3	Evaluation of the Residual Impacts	41
5.6.4	Identification of Monitoring Requirements	42
5.6	Impact Evaluation	42
5.6.1	Methodology for Impact Evaluation	42
6	CHAPTER 6. SCREENING OF IMPACTS AND THEIR MITIGATION MEASURE	45
6.1	Impact and Mitigation Management	45
6.1.1	Approaches for Mitigation Measures	45
6.2	Expected Positive Impacts	45
6.2.1	Increase in Employment Opportunities during Construction Phase	45
6.2.2	Efficient and Economic Residential Availability	46
6.3	Adverse Impacts and Mitigation Measures	46
6.4	Impacts Due to Project Location	46
6.4.1	Relocation of People	46
6.4.2	Loss of Vegetation	46
6.4.3	Shifting of Utilities	46
6.4.4	Impact on Archaeological/Cultural Property	46

6.5	Impacts Due to Project Design	47
6.5.1	Location	47
6.5.2	Designing.....	47
6.6	Impacts Due to Project Construction.....	47
6.6.1	IMPACTS ON PHYSICAL ENVIRONMENT	48
6.6.2	IMPACTS ON BIOLOGICAL ENVIRONMENT	52
6.6.3	SOCIO-CULTURAL IMPACTS	52
6.6.2	52	
6.7	Impacts Due to Project Operation	54
6.7.1	Water Consumption	54
6.7.2	Water Quality	55
6.7.3	Soil Contamination.....	55
6.7.4	Air Quality	55
6.7.5	Noise and Vibration.....	55
6.7.6	Solid Waste Management.....	56
6.7.7	Emergency Response.....	56
6.7.8	FIRE HAZARD	56
6.8	Potential Environmental Enhancement Measures.....	57
6.8.1	Tree Plantation	57
6.8.1	Facility Design	57
6.9	Social Enhancement Measures.....	57
6.9.1	Employment/Poverty Alleviation	57
6.9.2	Local Economy	57
7	CHAPTER 7.ENVIRONMENTAL MANAGEMENT AND MONITORING PLANS	58
7.1	Objectives	58
7.2	Management Approach.....	58
7.2.1	Proponent.....	58
7.2.2	Contractors	59
7.3	Components of EMMP	59
7.3.1	Remedial and Mitigation Measures	59
7.4	Environmental Management and Monitoring Framework.....	59
7.4.1	Environmental Management Team.....	66
7.4.2	Impacts Management and Monitoring Plans	67
7.5	Proposed Monitoring to Assess the Performance of EMP	67
7.6	SOCIAL MANAGEMENT PLAN	69
7.7	Proposed EMP Reporting and Reviewing Procedures.....	70
7.6.1	Primary Responsibilities.....	70
7.6.2	Operation Management & Control	70
7.6.3	Supervision & Monitoring	70
7.6.4	Communications & Documentation.....	70
7.6.5	Meetings	70
7.6.6	Changes-Record Register	70

7.8	Training and Capacity Building.....	70
7.9	Equipment Maintenance Details.....	71
7.10	Environmental Budget.....	71
8	7. PUBLIC CONSULTATION AND INFORMATION DISCLOSURE	72
8.1	Proponent's Environmental Management Team	72
8.2	The Responsible Authority	73
8.3	Objectives of Consultation.....	74
8.4	Identification of Stakeholders	74
8.5	Direct Stakeholders.....	74
8.5.1	Indirect Stakeholders	74
8.5.2	Other Departments and Agencies.....	74
8.6	Public Disclosure.....	75
8.7	Consultation Process	75
8.8	Environmental Practitioners and Experts	76
8.9	Affected and Wider Community.....	76
7.9.1	Views, Concerns and Suggestions of Various Stakeholders.....	76
8.10	Addressing Public Concerns	77
8.11	Acceptance Level of the Project.....	77
9	CHAPTER 8. CONCLUSION AND RECOMMENDATIONS	78
9.1	Merits and Demerits	78
9.2	Recommendations	78

LIST OF TABLES

Table 1: Salient Features of Project	1
Table 2: Vegetative Features of the Project Area.....	21
Table 3: Cost Breakup.....	21
<i>Table 4: Flora of the Study Site</i>	<i>33</i>
Table 5: Mammals in Study Area.....	34
Table 6: Birds in Study Area.....	34
Table 7: Reptiles in the Study Area.....	35
Table 8: Amphibians in the Study Area	35
Table 9: Insects in Study Area.....	35
Table 10: Impact Screening Checklist	43
Table 11: Impact Evaluation Matrix	44
Table 12: Approaches for Mitigation Measures	45
Table 13: Environmental Management Plan.....	60
Table 14: Roles and Responsibilities.....	66
Table 15: Environmental Monitoring Plan	69
Table 16: Training and Capacity Building Plan	70

LIST OF FIGURES

Figure 1: Project Area	20
Figure 2: Road Access Plan	20
Figure 3: Design of Gas Detectors	25
Figure 4: Seismic Zoning Map of Pakistan	30
Figure 5: Average Annual Temperatures and precipitation in Sheikhpura	31
Figure 6: Maximum temperature ranges in Sheikhpura	31
Figure 7: Annual Precipitation amounts in Sheikhpura	32
Figure 8: Annual average wind speed in Sheikhpura.....	32
Figure 9: Wind Rose diagram of Sheikhpura	33
Figure 10: Consulted age groups in the area near project site	37
Figure 11: Occupation of Respondents.....	37
Figure 12: Literacy Rate.....	38
Figure 14: Hierarchy of Mitigations.....	41

CHAPTER 1. INTRODUCTION

1.1 General

Currently out of 45 million households in Pakistan, 4.3 million are connected to natural gas network and the rest are relying on LPG and conventional fuels like coal, firewood, kerosene, dung cake etc, which indicate the strong demand for Liquefied Petroleum Gas (LPG) sector.

Liquefied Petroleum Gas (LPG) is used as fuel for cooking and heating in the northern Pakistan particularly in Punjab. It is also used as fuel in vehicles particularly taxi and rickshaws. More than 30,000 rickshaws and taxis in Karachi and other parts of the country are run on LPG. The demand of LPG in Karachi is consistent throughout the year and increases during winters in Punjab and Northern Pakistan. Although demand of LPG is persistent throughout the year, supply of LPG from producers (or extractors) to distributors and marketing companies has been limited due to maintenance and overhauling shutdowns, which often creates shortages. Besides that, LPG producers are also limited in numbers and LPG marketing companies need to have a quota of gas to be allocated by the producer. This factor makes LPG business vulnerable in the hands of LPG producers.

LPG (Liquefied Petroleum Gas) is the generic name for commercial propane and commercial butane. These are hydrocarbon products produced by the oil and gas industries. Commercial Propane predominantly consists of hydrocarbons containing three carbon atoms, mainly propane (C_3H_8). Commercial Butane predominantly consists of hydrocarbons containing four carbon atoms, mainly n- and iso – butanes (C_4H_{10}). They have the special property of becoming liquid at atmospheric temperature if moderately compressed and reverting to gases when the pressure is sufficiently reduced. Advantage is taken of this property to transport and store these products.

1.1.1 Screening

For the prediction and mitigation of the impacts of development at an early stage, it is prerequisite under the environmental laws of the country to undertake Initial Environmental Examination (IEE) and Environmental Impact Assessment (EIA). As per the statutory notification of Review of Initial Environmental Examination (IEE) and Environmental Impact Assessment (EIA) Regulations, 2022 made under Section 12 of Punjab Environmental Protection Act, 2012, the project for the Establishment of an Auto fuels storage and refilling station occurs under **Schedule II category A (5)**.

1.2 Purpose of study

The establishment of any Project leads to positive and adverse changes in environmental and change in social settings of the Project Area. The intensity and level of change, however, depends upon the nature of the Project and the baseline environmental conditions of the area. The commencement of a project will cause minor to moderate adverse environmental and social impacts on the surrounding area. Thus, an environmental and social study is mandatory to establish the baseline conditions, evaluate the possible adverse impacts if any, and devise the mitigation measures.

The predominant objectives of this EIA report were:

- To assess and report the prevailing environmental conditions of the project area.
- To develop a baseline in order to evaluate the suitability of the project in particular area.
- To recognize activities during pre-development, development and operation of project and its associated impacts.
- To assist the proponent for planning, designing and implementation of the project, keeping in view the elimination or minimization of negative impacts.
- To develop proper mitigation as well as monitoring plans for the uniform implementation.
- To provide opportunity to the public for a better understanding of the project as well as its impacts on community and environment in context of sustainable development.
- To prepare an EIA report for the submission to Environmental Protection Agency, Punjab for Environmental Approval.

As per PEPA 2012 and the IEE/EIA Regulations, 2002 it is mandatory for the proponent of any development project to accord Environmental Approval from EPA Punjab by filing an IEE or EIA as the case may be, before the Agency. The said project is proposed to meet the petroleum requirements of customers. This Report presents the Environmental Impact Assessment (EIA) for this proposed project. For this purpose, the proponent has decided to engage environmental consultants, **M/S EnvironTech Consultants**. The purpose of this study is to identify the environmental baseline i.e. physical, biological and socio-economic/cultural conditions and assess all possible impacts arising during the construction and operation phase of the project with the aim to find out appropriate measures for their mitigation, to either eliminate those impacts or to bring them to acceptable level and formulate Environmental Management Plan (EMP) for implementation of the project in environment-friendly manner.

The report provides relevant information, as required under the officially approved format, to help the decision makers i.e. EPA Punjab before issuing for the Environmental Approval.

1.3 The Proponent

Name: Muhammad Asif Javed S/O Muhammad Yousaf.

Address: P.O. Batapur, Umar Khan Road, Manawan Tehsil Shalimar District Lahore.

1.4 Details of Consultant

The services of environmental consultant M/s **EnvironTech Consultants** have been taken by the proponent for the formulation of Environmental Impact Assessment (EIA) Report. EnvironTech Consultants (PVT) Ltd is an environmental consultancy firm that has an unrivalled reputation for providing high quality tailored services. EnvironTech Consultants (PVT) Ltd is a dynamic, responsive and innovative in providing these cost-effective solutions. EnvironTech Consultants (PVT) limited comprising of Environmental Engineers & Consultants and rendering their services to clients in both industrial and the government sectors.

With the visionary leadership of its veteran management and enthusiasm of its team, it is committed to come up with innovative ways of maintaining and enriching the Environmental Profiles / Portfolios of its prestigious clients with activities having a strong and lasting impact to their corporate image. It has attracted and retained staff with an unrivalled depth and breadth of expertise and experience that they have from working, not just in consultancy but also in commercial, industrial and regulatory environments. With its pool of Environmental Consultants, Environmental Scientists and Environmental Engineers, company offers one stop solutions tailored to its client's needs.

Contact Details:

Focal Person	Kamal Ahmed Cheema
Address	Office #11, 2 nd Floor, Center Point Plaza, Lahore
Contact No.	0303-4342302

1.4.1 Team Members

Qualified professionals with relevant experiences of conducting environmental assessment have contributed to the preparation of Environmental Impact Assessment (EIA) Report. The List of team members has been attached as an Annexure-VI along with their roles and responsibilities:

1.5 Brief Description of Nature, Size, And Location of Project

The Proposed Project is titled as of Marhaba LPG Traders (PVT) Limited. For establishing LPG storage & Filling Plant. Its salient features have been described later in this Chapter, Chapter 2 and briefly in Executive Summary of this EIA Report.

1.5.1 Nature of Project

This project is the Construction of LPG Storage & Filling Plant.

1.5.2 Size of Project

Proposed Project will have an LPG capacity to store 100 MT. Two tanks will be installed of 50 MT capacity each and filling capacity of 25 MT/Day.

1.5.3 Location of Project

The Proposed project is located at Mouza Dhenga, Tehsil Ferozewala and District Sheikhpura.

1.5.4 Area of Project

Total area of the Project is 24 Kanal.

Chapter 2. Screening and Scoping

2.1 Screening/Type and Category of Project

Section 12 of Punjab Environmental Protection Act, 1997 (amended 2012) states “No proponent of a project shall commence construction or operation unless he has filed with the Government Agency designated by Federal Environmental Protection Agency or Provincial Environmental Protection Agencies, as the case may be, or, where the project is likely to cause an adverse environmental effects an Environmental Impact Assessment (EIA), and has obtained from the Government Agency approval in respect thereof.” Punjab Environmental Protection Act provided the guidelines for categorizing the projects. According to **Schedule-II** of IEE and EIA Regulations, 2022; the proposed project falls under **Category A (Oil and gas extraction projects including exploration, production, gathering systems, separation and storage)** i.e., the project requires an EIA Study. Thus, an EIA Report is being prepared and submitted accordingly for approval.

2.2 Scoping:

1. Spatial and Temporal Boundaries of Environmental Assessment:

Temporal and spatial boundaries for the effects assessment are defined by the characteristics of the project and the VECC being assessed. These boundaries encompass time periods and areas during and within which the VECCs are likely to interact with or be influenced by the project.

- Temporal Extent (during construction and operation)
- Spatial Extent (local or widespread)

2. Views, Concerns and Suggestions of Various Stakeholders

Community showed a lot of concerns; a few are being mentioned here:

- ✚ Removal of shrubs and trees should be avoided to the extent possible
- ✚ The project will become the source of income for local to earn their livelihood easily and honorably
- ✚ The area will become further commercialized
- ✚ For the solid waste management and waste disposal, proper disposal techniques should be adopted
- ✚ Employment opportunities will be generated, and locals should be hired on the priority basis
- ✚ The air pollution is one of the major impacts of the proposed project, so ambient air quality should be monitored regularly
- ✚ Water spraying/sprinkling should be done on the regular basis during construction phase to avoid dust emissions
- ✚ Removal of shrubs and trees should be avoided to the extent possible
- ✚ Good relations with the local communities will be promoted by encouraging Contractor to provide opportunities for skilled and unskilled employment to the locals as well as on-job training

- ✚ The contractor should prefer hiring local labor from adjacent nearby villages
- ✚ Indigenous trees around the facility should be planted to control air pollution and as the compensation
- ✚ Noise reducing barriers should be installed to reduce noise pollution as the nearest community lies within the radius of 0.8 km

Concerns

- ❖ Workers should be hired from local community
- ❖ Proper disposal of solid waste should be practiced
- ❖ Indigenous trees around the facility should be planted to control air pollution
- ❖ Removal of shrubs and bushes should be avoided to the extent possible

3. Significant impacts and factors to be determined

Main impacts and factors to be determined are:

- Occupational Health and safety
- Site Security
- Traffic Management
- Hygiene management
- Job opportunities for locals
- Resource conservation
- Avoid excessive water consumption
- Energy efficient techniques must be adopted
- Proper site restoration after construction
- Tree plantation at designated green areas
- Emergency preparedness

2.3 Alternatives

The details of the site alternatives and technology alternatives are discussed below:

2.3.1 Technology Alternative

LPG is well positioned to assist developing countries in the transition to modern fuels for the following reasons:

1. Availability: There is nothing exotic to invent or improve. The transportation system that moves it is in place, the tank to store it is available, and the appliances and equipment that provide heat and power are "on the shelf".
2. Infinite shelf Life: LPG does not deteriorate over time unlike some other liquid fuels that gel, stratify or evaporate and must be protected from weather to prevent deterioration.
3. High energy density: Compared to traditional fuels in terms of weight equivalency, LPG has ten times energy.

4. Environment friendly: It burns cleanly without smoke or residual ash, thus avoiding the health hazards associated with indoor use of traditional fuels in the event of a leak, LPG doesn't contaminate the soil or aquifers.
5. LPG can be transported, stored, and used virtually anywhere in the world. It does not require a fixed network and does not deteriorate over time.
6. LPG is very clean burning and has lower greenhouse gas emissions than any other fossil fuel when measured on a total fuel cycle.
7. LPG is cost-effective, since a high proportion of its energy content is converted into heat. LPG can be up to five times more efficient than traditional fuels, resulting in less energy wastage and better use of energy resources.

LPG has many technology advantages over other fuels, it is a cheaper and green fuel hence any other fuel project couldn't be considered.

2.3.2 Site Alternatives

No site alternative was considered for the aforesaid project as the site selected for the establishment of the aforesaid project (Marhaba LPG Traders (PVT) Limited). The selected site is undisputed, and it is under the ownership of proponent. The site is most feasible in context of social and environment position as well as in achieving the intended objectives. The selected site also houses no ecologically sensitive area within a safe radius. It is best suited for the project.

Moreover, the **site is considered suitable** because of the following features:

- The proposed site falls under the jurisdiction of the proponent and has been acquired for construction of a unit. It has been observed to be almost level in topography, with sparse vegetation located inside the site area.
- No endangered fauna/flora has been observed near the project site.
- The proposed site does not fall in any category of protected or environmentally sensitive area.

The location of project is best suited for proposed activities. So, no alternative for site is analyzed.

2.3.3 Environmental Alternatives:

No important religious, archaeological, recreational site or ecologically/declared protected area and human settlement exists within proximity of the selected site i.e., within 4 Km which is a safe distance. In view of these facts, it can be concluded that the selected site is best suited for the project and will not pose any adverse impact or threat on any component of the environment.

2.3.4 Economic Alternatives:

The technology selected for establishment of above stated project will be economical viable than alternatives present as compared to majority of the other available production technologies but it will be most efficient and convenient to use.

CHAPTER 3. PROJECT DESCRIPTION

This section of the study concentrates on details of the project and its salient features; such as location, site layout, objectives, selection of alternatives, cost and magnitude of operation and various phases. Inputs and discharges relevant to different phases of the project, such as electricity & materials, etc. have also been examined as a response to possible environmental concerns.

3.1 Screening/Type and Category of Project

Section 12 of Punjab Environmental Protection Act says that no proponent of a project shall commence/undertake construction or operation of any sort unless they had filed with the Provincial Agency an Initial Environmental Examination (IEE) and an Environmental Impact Assessment (EIA), where the project is likely to cause an adverse environmental effect. The Proponent has to secure approval from the Provincial Agency in respect thereof. Punjab Environmental Protection Act provided the guidelines for categorizing the projects. As per Review of Initial Environmental Examination (IEE) and Environmental Impact Assessment (EIA) Regulations, 2022 the Proposed project falls in the **Schedule-II** of the projects mentioned in **Category A-5 (Oil and gas extraction projects including exploration, production, gathering systems, separation and storage)**".

The proposed project is the establishment of Storage and filling plant. Total cost of the project 70 million.

3.2 Objectives of Project

Present Project has following objectives.

- i. It is expected to benefit local population.
- ii. To provide job opportunities to local public and to improve their living standards
- iii. To improve the economic activities
- iv. Maintain continuity in supply of LPG gas to the consumers through distributors and quality of services to the consumers.
- v. Private investment will be beneficial for the national economy and GDP as well.
- vi. Ease in availability of filled LPG during crisis period.
- vii. Help to overcome the scarcity of bulk LPG due to huge gap between demand and supply.
- viii. Help to overcome the scarcity of bulk LPG due to huge gap between demand and supply.

3.3 Location and Layout of Project

The proposed location for the establishment of proposed project of Marhaba LPG Traders (PVT) Limited at Mouza Dhenga, Tehsil Ferozewala and District Sheikhpura. The geographical location of the proposed area 31°36'34.4"N 74°08'17.4"E.

The elevation of the project area is 758ft from the sea level. The total demarcated project area is given below:

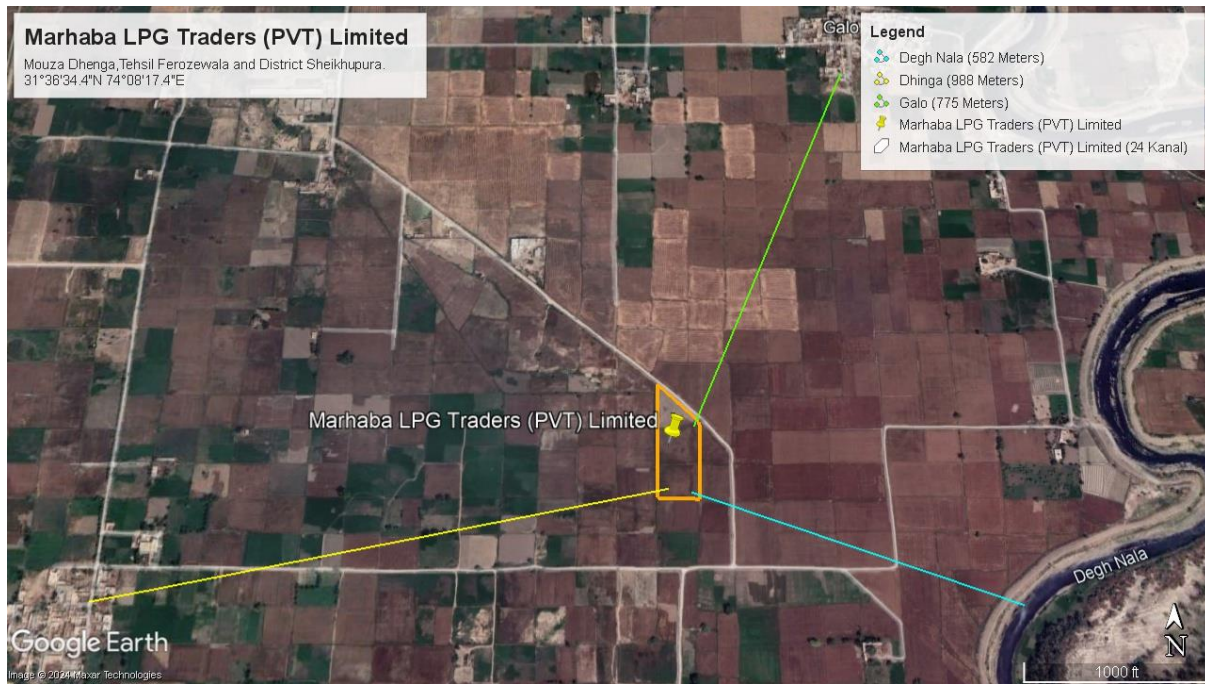

Figure 1: Project Area

The surface land in and around the project area is leveled and Self-developed commercial. No ecology sensitive receptor such as; forest or reserved area is present within **4 km** vicinity that could be impacted due to the establishment of this project.

3.4 Land Use on Site

Open commercial land.

3.5 Road Access

The project site is well connected to road network i.e., **Galo Road**. The road network is shown below in Figure.

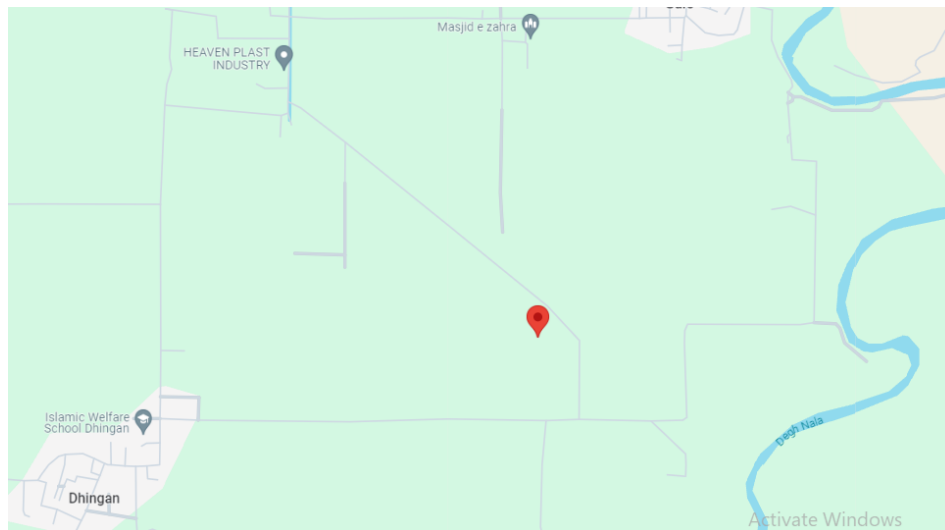

Figure 2: Road Access Plan

3.6 Vegetative Features

The area around the project area is Self-developed commercial. There are no such vegetative features in or around the area include except some self-growing trees of kikar and wild grass.

Table 2: Vegetative Features of the Project Area

Sr.#	Local Name	Type	Biological Name
1	Kikar	<i>Throne Tree</i>	<i>Prosopis juliflora</i>
2	Wild Grasses	<i>Grass</i>	--

3.7 Cost and Magnitude of Operation

The major raw material for the plant is LPG which will be transported in tankers to the plant, maintaining safety standards. Total cost of proposed project is 70 million PKR with total storage capacity of 100 MT and 25 MT/day filling capacity. Furthermore, Project involves NOCs obtaining cost, construction cost, cost of storage tanks, PPEs, safety equipment's and purchase of LPG. Total cost of the project is 70 million PKR. Despite all these costs, project is found to be feasible.

Table 3: Cost Breakup

S#	Kinds of Cost	Amount in Million
	Land Cost	20.2
	Obtaining NOCs from OGRA and other departments	11
	Installation of Equipment/Machinery	19.6
	Land Development, Infrastructure & Construction Cost	17.2
	Environmental Budget	2 million
	Total Cost	70 million

3.8 Schedule of implementation

It is projected that the construction phase of entire project will be started after getting environmental approval from EPA Punjab and complete in the period of 5-6 months. Activities involved are:

- Assessment of environmental impacts and its mitigation measures
- IEE approval, other local issues
- Implementation of recommended alteration in system, if required
- Commencement of operation

3.9 Project Description

3.9.1 Raw Materials

The major raw material for the plant is LPG which will be transported in tankers to the plant, maintaining safety standards. The LPG is imported / local through Karachi port and is brought through bowsers.

3.9.2 Final Product

Storage and bottling of LPG.

3.9.3 Capacity

The project envisages at construction of storage and filling station which has a filling capacity of 100 tons/day.

Specifications of cylinder

- Volume: 5000 L
- Design Pressure: 1.77 (MPa)
- Tank Size (Diameter x length x Thickness mm)
- 1200x4000x10
- Outer Size [Dia x H/L (mm)]
- 1220x1650x4794
- Material
- Stainless Steel

3.9.4 Plant Utilities and Machinery

- ✚ LPG Storage Tank
- ✚ Decanting Pumps & Transfer pumps
- ✚ Pipes with structural steel support
- ✚ Ball Valve
- ✚ Cylinders
- ✚ Firefighting system
- ✚ Water sprinkler systems
- ✚ Evacuation system
- ✚ Pressure differential valve
- ✚ Pop action relief
- ✚ Non-return valve

3.10. Fire Copping System

Description	Quantity
DCP Trolley Mounted 50 kg	2
DCP fire extinguishers 6kg	4
Co2 fire extinguisher 5 kg	2
Halotron fire extinguisher	2
Fire blankets	2
Portable extension aluminum/fiber ladder	1
Fireproof suit	1
First aid box with necessary equipment's	1
Fire point (8 buckets, 1 shovel, 1 fireman axe)	1
Gas protective goggles	4
Face shield	4
Gum boots	4 pairs

Safety helmets	As per requirement
Suitable gloves	As per requirement
Portable torch (high beam)	As per requirement
Breathing apparatus	As per requirement
CCTV cameras	02
Emergency Shutdown Valve	02
Fire Hydrant	04
Fire Monitor	04
Fire water pump 500 GPM	1
Showering Pump 500 GPM	1
Jockey pump	1
Manual Sprinkler	75
Auto Sprinkler	25
Fire extinguisher DCP 09 KG	12
Trolley Mounted	03
Fire Ettinger CO ₂ (05 kg)	05
Filling Machine	4
Earth Pits	11
Sand Bucket Stand	03
Fire Alarm	01

3.10 PROCESS DESCRIPTION

LPG is transported through bowzers to the storage and filling plant where LPG is stored in tanks and filled into vehicle for storage and filling into the vehicles. Transfer operation of LPG is very critical, as LPG is a highly inflammable product and the systems are required to be intrinsically safe. The systems also require very comprehensive fire safety arrangements.

3.11.1 Filling of Storage Tanks

LPG tankers will arrive on site and enter through main gate of plant. Tanker will be attached to the bowser point and LPG will be transferred from Mobile tanker to storage tank.

3.11.2 Transfer of LPG to Filling Station

Single pump is used to transfer LPG from storage tank to transfer station via transfer pipes. Transfer pipes are provided with fire water lines in case of emergency fires.

3.11.3 Visual Inspection / Segregation of Cylinders

Cylinders found unfit for filling on visual inspection e.g., heavily rusted or heavily dented will be separated during visual inspection. Cylinders having twisted valve spindle, broken/bent foot protection ring would also be segregated.

3.11.4 Final Inspection

Cylinders are visually inspected to examine their sound condition and presence of valve protection.

3.11 SUPPLIES

3.12.1 Water Supply

Water will be extracted from underground water sources. The management will install Motor pump for extraction of ground water for both water storage tank and other purposes. The ground water will be pumped from 100-120ft. The total water requirement will be 200 gallons per day.

Wastewater Generation Rate = $0.74\text{m}^3/\text{day}$

Detention Time (T_d) = 2.5 hours

Volume (V) = 0.07 m^3

Depth (D) = 3m

Area (A) = 0.02 m^2

Diameter (d) = 0.15m

3.12.2 Fire-Fighting System& Emergency Response Plan

Emergency Response & Evacuation Plan is designed to respond an emergency arises (medical, fire, disasters etc.) and provide a process for continuous medical support and evacuating people from danger, protect assets, property and to restore operations to normal as quickly as possible. Their objective is to provide a safe and healthy environment for employees, contractors, visitors, and guests.

In the event of an emergency, the Emergency Response Team (ERT) will respond immediately to take appropriate actions. Frequent drills/training will be conducted to ensure that they react in an organized manner.

3.12.3 Electricity

Source of power will be WAPDA (GEPCO) only.

3.12.4 Manpower

A total of 5-10 employees including mechanically, electrical, machine operators, sweepers and other managerial and office staff shall be working here.

3.12.5 Health, Safety & Hygiene

Health, Safety & Hygiene includes the following:

3.12.6 First Aid facility

At workplace workers and employers should have enough information, knowledge and training regarding first aid treatment in case of any emergency. The subject project will provide proper medical facilities to

workers and staff to cope with any incidental accidents and proper training about first aid will be provided to workers and staff.

3.12.7 Safety Trainings

Workers and all the staff will be provided with proper training about the work and safety practices.

3.12.8 Use of Drugs and Narcotics

Drugs and narcotics are strictly prohibited during working hours in working area. Smoking will be only allowed in rest timings at properly isolated places.

3.12 Leakage Detection System:

Gas detectors equipped with alarms will be used to detect any leakages in the unit. This will help in early response in case of emergencies. The design of gas detectors is given below:

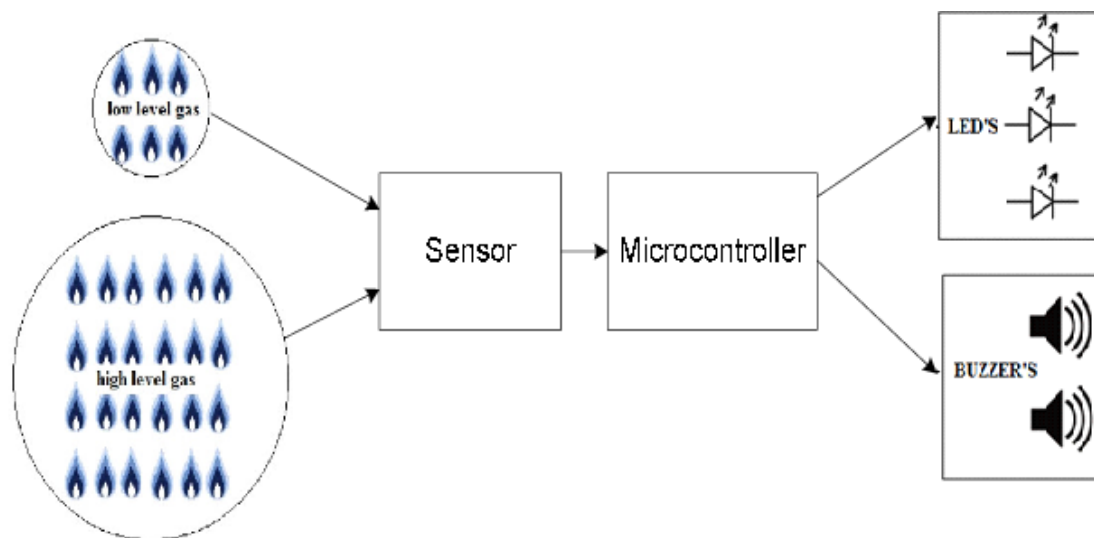

Figure 3: Design of Gas Detectors

Mitigation Measures for accidental leakage

- If a gas leak is detected, the valve of the main gas pipe can be closed immediately to stop the flow of gas.
- Identifying the specific portion of the tank or tank system that has caused a subsurface release is a critical first step
- The site's emergency shutdown, shall be exhibited which triggered the sirens, cut electricity supply (except for lighting), closed the spherical container valves as well as inlet valves
- Fire hydrants will be made available. Removing flammable or explosive materials from the release area.
- contact to qualified professionals who will be able to provide quick assistance to help reduce costs and liability

3.13 Personal Protective Equipment

To control any health and safety risk and to reduce the magnitude of any adverse impact, we have to devise control strategies and adopt them in the following category order:

- ✚ Control at source
- ✚ Propagation Control
- ✚ Control at receiver end

Of these three, the first two are of prime importance but the last one should always for every risk at every workplace; standardized according to the working conditions and the people employed in the job. The first two effectively mitigate the risks and impacts but the third one compensates the left over and unavoidable losses by protecting the receiver and keeping it to a tolerable exposure level for that impact/risk. For this purpose, the equipment provided are termed as ‘Personal Protective Equipment’.

Following PPEs will be provided in project

- ✚ Safety Helmet
- ✚ Safety Shoes
- ✚ Safety Masks
- ✚ Safety Jackets

3.14 Wastewater Source and Treatment

Effluent arising from domestic activities will be treated in septic tanks and then will be released into soakage pit, to address the water depletion issue. LPG storage and filling activities give rise to no waste effluent hence wastewater treatment system is not required. The detailed design of septic tank is given below:

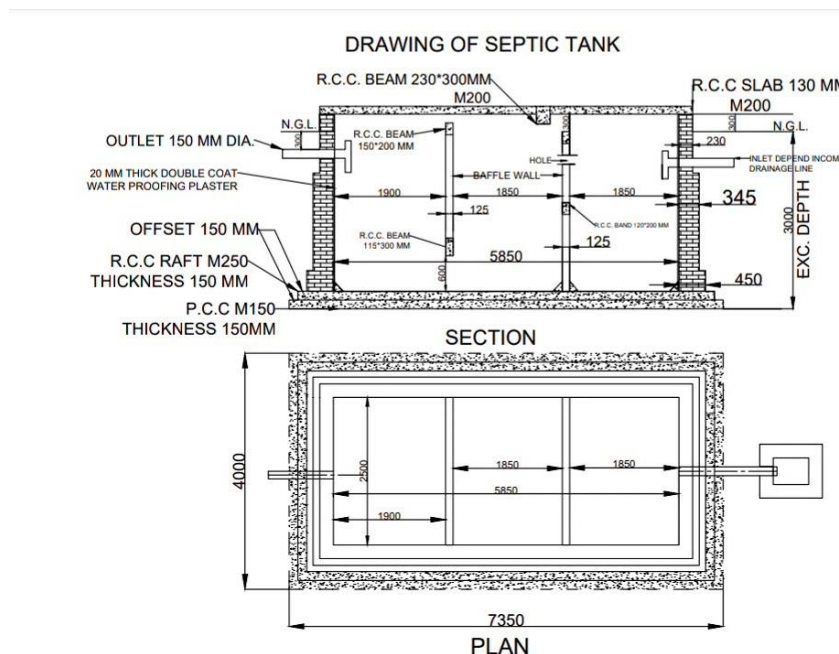

3.15 Air Emissions Source and Treatment

No Air emissions are expected during process. In case of leakage, broken down pipes, LPG could escape which will have certain impacts on workers. For this, Gas detectors will be provided. Further PPEs will also be provided to workers. PM from floor cleaning is also insignificant as wet suppression will suppress the dust emissions.

3.16 Noise Source and Treatment

During operation, loading and unloading will be the cause of noise. Proper tuning of vehicles will mitigate this problem. Moreover, Tree Plantation along the boundary of Proposed Project and Plantation within the unit will further reduce noise since plants and trees serve as noise absorbers. Construction activities noise will be temporary and will be mitigated by measures as stated in Chapter-5&6.

3.17 Solid Waste Source and Treatment

Solid waste will be municipal in nature and will be handled by solid waste management contractor as per TMA practices.

3.18 Relocation and Rehabilitation Plans

No human population resides within project area as the land is owned by the proponent. The nearest populated area is approximately 775 Meters (Galo) away from the aforesaid project location. No structure of any significance (cultural, religious, archaeological, recreational or any other) stands on the land selected for the project requiring dismantling or relocation. No flora or fauna; especially belonging to endangered species is found within a safe distance from the site which will be removed or moved to some other part. Hence, no relocation and resettlement is required.

The land ownership documents showed that land is owned by Proponent and the land ownership documents are attached as Annexure of this EIA Report. Moreover, there is no dispute and rehabilitation associated with the establishment of LPG Storage & Auto Filling Plant of “**Marhaba LPG Traders (PVT) Limited**”. The site will be restored, and construction debris will be removed from site at the end of construction phase.

Till the date proponent have no other plans to switch his business or site and in coming years upon decommissioning of the proposed project, rehabilitation of the project site will be carried out to restore the site to its original status or to a better state than it was originally.

This will include replacement of topsoil, refilling of bowser’s excavated area and re-vegetation which will lead to improved visual quality of the area.

3.19 Land ownership Documents

Land Ownership documents have been attached as Annexure of this EIA Report, which clearly shows that the selected area for the establishment of Marhaba LPG Traders (PVT) Limited is under the ownership of proponent.

3.20 Government Approvals

They have applied for environmental approval from EPA Punjab.

CHAPTER 4. DESCRIPTION OF THE ENVIRONMENT

This chapter provides baseline data (physical, biological and socio-economic parameters) related to the project and study area. The information has been compiled by using primary and secondary data resources. This chapter also refers to the theoretical analysis of the methodology adopted for collection of baseline data. The underlying principles and practices adopted in this regard are also discussed.

4.1 Methodology

The methodology employed to collect the baseline data and information regarding the social structure and various related parameters as discussed in sub-sections below:

4.1.1 Data Collection

The primary data was collected by visiting the project area and its communities in its nearby vicinity. The secondary data regarding physical parameters (topography, geology, seismology, and climate) was obtained by visiting relevant various government departments and their official websites. The biological parameters such as flora and fauna were studied by preparing a floristic list based on visual observation and fauna was studied by using opportunities approach. The species were recorded with reference to their existence in the project area. Information on wildlife fauna species (mammals, amphibians, reptiles, birds, etc.) in the assessment area was compiled based on opportunistic observation, gathering the existing information and consultation with local experts, community members and government and Non-Government Organizations (NGOs). The socioeconomic aspects were studied and analyzed by studying detailed village profile and by conducting household surveys.

4.1.2 Social Survey

The purpose of social survey was to record the present condition of the people living in the project area and to assess the expected project impacts on their life, subsistence systems and socio-cultural conditions. Prior to conducting the field surveys, the following steps were taken:

- Clear boundaries of the project area were identified
- Decided the sampling procedure in order to draw a representative sample size of the target population and households
- Developed the tools for data collection i.e. questionnaires to access the socio-economic status of the area

4.1.3 Sampling Design

Social baseline data of the persons residing in the study area has been estimated and collected through random sampling by using pre-developed questionnaires.

4.1.4 Questionnaires

In order to test the validity and reliability of the proposed questionnaires, they were reviewed to assess whether questions needed to be clarified, changed or re-sequenced and then a final editing of

questionnaires was conducted prior to their application in the project area. The sample of socio-economic questionnaires used is attached as Annexure.

4.1.5 Data Editing and Analysis

The filled questionnaires and recorded information were compiled by the same field investigators who were involved in the data collection. This was done immediately after completing the field investigations. Data sets were processed. Analysis of the data and preparation of conclusions in the minimum possible time was done using statistical techniques of data analysis.

4.2 Review of Legal and Administrative Framework

The objective of reviewing legal and administrative framework is to obtain information on all legislation pertaining project development. The Socio-Environment Team of EnvironTech Consultants (PVT) Ltd. reviewed the environmental policies, national, international and provincial laws and guidelines relevant to the development of project which helped in systematic identification of impacts.

4.3 Baseline Conditions

This chapter provides baseline data (physical, biological and socio-economic parameters) related to the project and study area

4.4 Physical Environment

Pakistan Can be divided into five broad physiographical regions. These are the mountainous regions of the north, the western highlands and plateaus, the sub-mountains Indus region, the Potohar Plateau, Salt Range, and the Indus Plain. Brief description of these regions is given below:

Region	Characteristics	Location	Height
Northern Mountainous	Hindu Kush Karakoram and Himalayan Mountain Ranges	Northern Part of KPK, Gilgit Agency, Northern Areas and Kashmir.	Rises above 8,000m
Western Highlands and Plateaus	Toba Kakar, Sulaiman, Central Baruhi, Saihan, Central Makran, Makran Coastal and Kirthar Ranges	Mainly in Baluchistan, also parts of Sindh and KPK	Between 1,200 to 3,000 m
Sub-Mountains Indus	Alluvial filled Basins	Plains of Peshawar Kohat and Bannu	Less than 1,000 m
Potohar Plateau and Salt Range	Flat to gently undulating surface, broken by gullies,	Mainly northern parts of Punjab, some parts of KPK	Less than 1,000 m
Indus Plain	Flood plains of the Indus, Jhelum, Chenab Ravi and Sutlej Rivers	Punjab and Sindh	Less than 1,000 m

4.4.1 Topography

Sheikhupura the city of Punjab province, eastern Pakistan. In the town center stands a fort of the Mughal emperor Jahangir (completed 1619) that also served as the 19th-century residence of one of Ranjit Singh's queens; outside the city, the massive Hiran Minar tower overlooks the countryside. Shekhupūra

is connected by road and rail with Lahore (25 miles [40 km] southeast) and various other cities. It is an industrial center that makes food products and textiles. The city is in a section of alluvial plain known as the Bar tract, which is irrigated by the Chenab Canal system.

Sheikhupura is an industrial city in the northwest of Punjab province, Pakistan. The city is also the administrative headquarter of the Sheikhupura district and is approximately 38 km from Punjab’s provincial capital, Lahore. The town is famous for its historical monuments and also known as the city of Mughals, where emperors come for hunting. The city is also well-known for its booming industry. District Sheikhupura is bounded on the North by Gujranwala and Hafizabad districts, on the North-East by Narowal district, on the West and South-West by Nankana Sahib District, on the East by Lahore district.

Project Site:

The proposed project site is located in District Sheikhupura.

4.4.2 Hydrology

Groundwater from depth of 100 ft can be used for drinking and other purpose. Groundwater is the major source of water in the study area, which is extracted with the help of pumps and motors. The groundwater extracted is used to fulfill various domestic, irrigation and industrial needs. Ground water quality report of area is annexed. No surface water body is present within 5 km radius of the project site.

4.4.3 Seismicity

According to Seismic Zoning of Pakistan, the project area lies in Zone 2A and represents minor to moderate damage due to earthquakes.

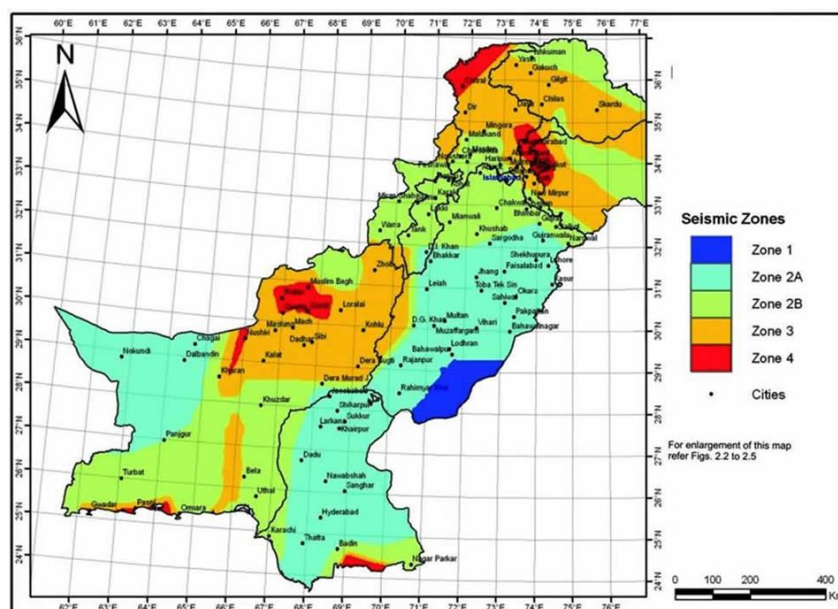

Figure 4: Seismic Zoning Map of Pakistan

4.4.4 Climate

Due to its high evaporation rate, Sheikhupura features hot desert-like climatic conditions according to Koppen-Geiger classification. The climate of the district can see extremes, with a summer maximum temperature 44°C and a winter temperature of 4.0°C The mean maximum and minimum temperature in

summer are 43.5°C and 18.0°C respectively. In winter it peaks at around 19.4°C and 4.1°C respectively. The summer season starts from April and continues till October. May, June and July are the hottest months. The winter season starts from November and continues till March. December, January and February are the coldest months. “The bulk of monsoon precipitation occurs in July and August, with monthly averages of 115.0 mm and 89.8 mm respectively. Minimum rainfall occurs in the month of November which is 3.0 mm” (PMD).

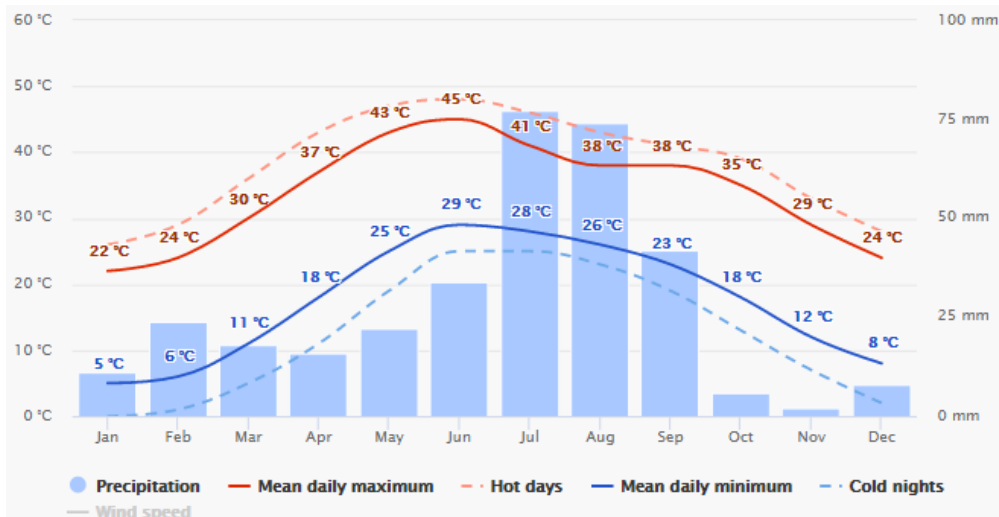

Figure 5: Average Annual Temperatures and precipitation in Sheikhpura

The "mean daily maximum" (solid red line) shows the maximum temperature of an average day for every month for sheikhpura. Likewise, "mean daily minimum" (solid blue line) shows the average minimum temperature. Weather in sheikhpura is influenced by Subtropical Dry Semiarid Steppe climate. Low-latitude dry climate. Evaporation exceeds precipitation on average but is less than potential evaporation.

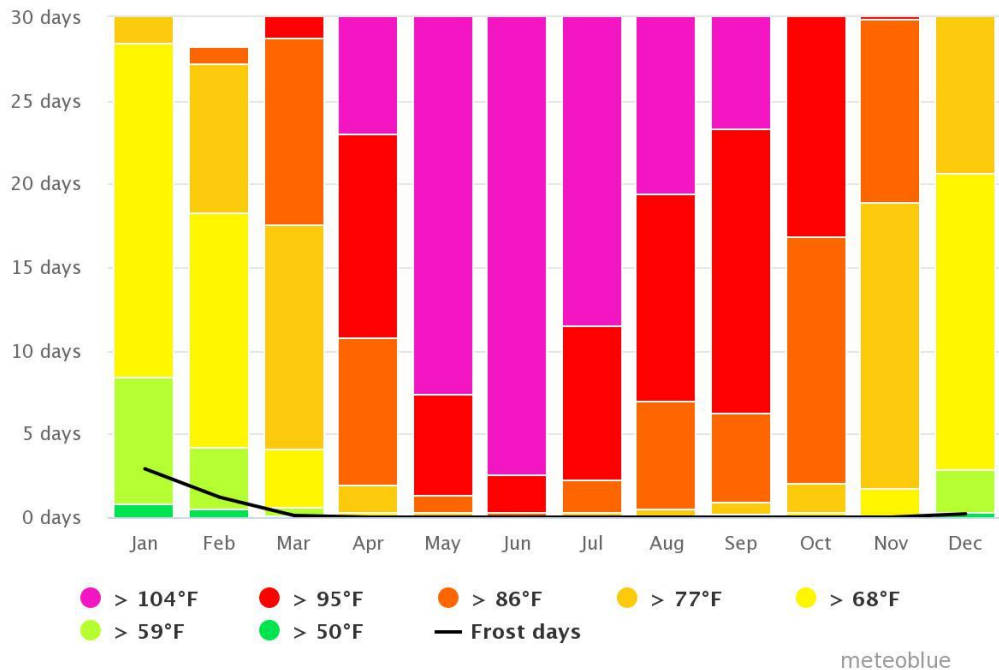

Figure 6: Maximum temperature ranges in Sheikhpura

The graph shows the monthly number of sunny, partly cloudy, overcast and precipitation days. Days with less than 20% cloud cover are considered as sunny, with 20-80% cloud cover as partly cloudy and with more than 80% as overcast.

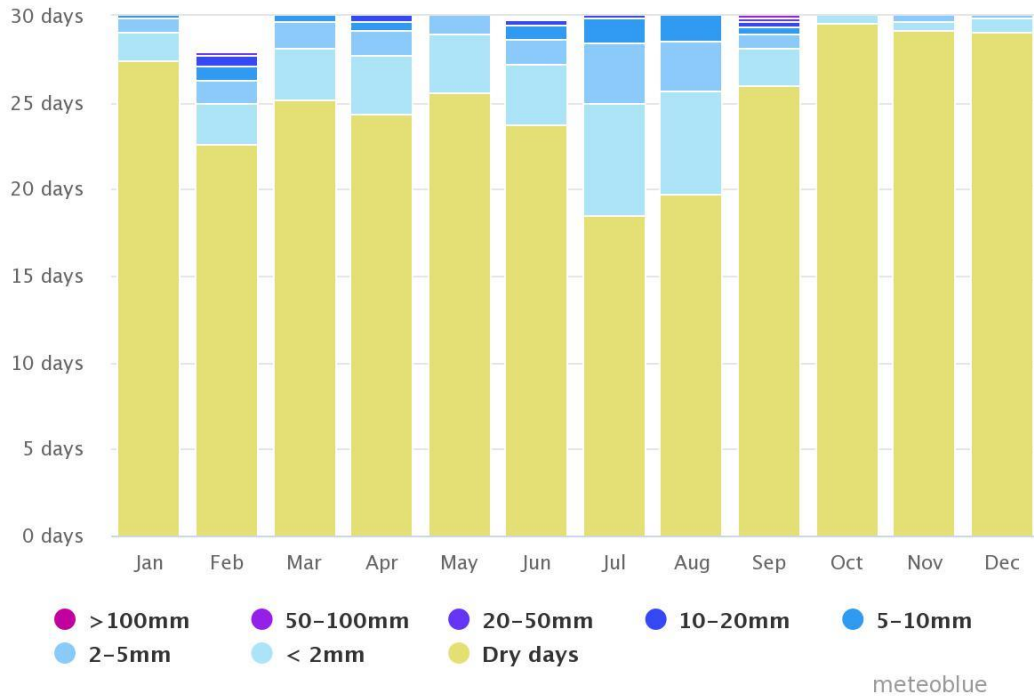

Figure 7: Annual Precipitation amounts in Sheikhupura

4.4.5 Wind

The diagram for Sheikhupura shows the Max and Average Wind speed and Wind Gust.

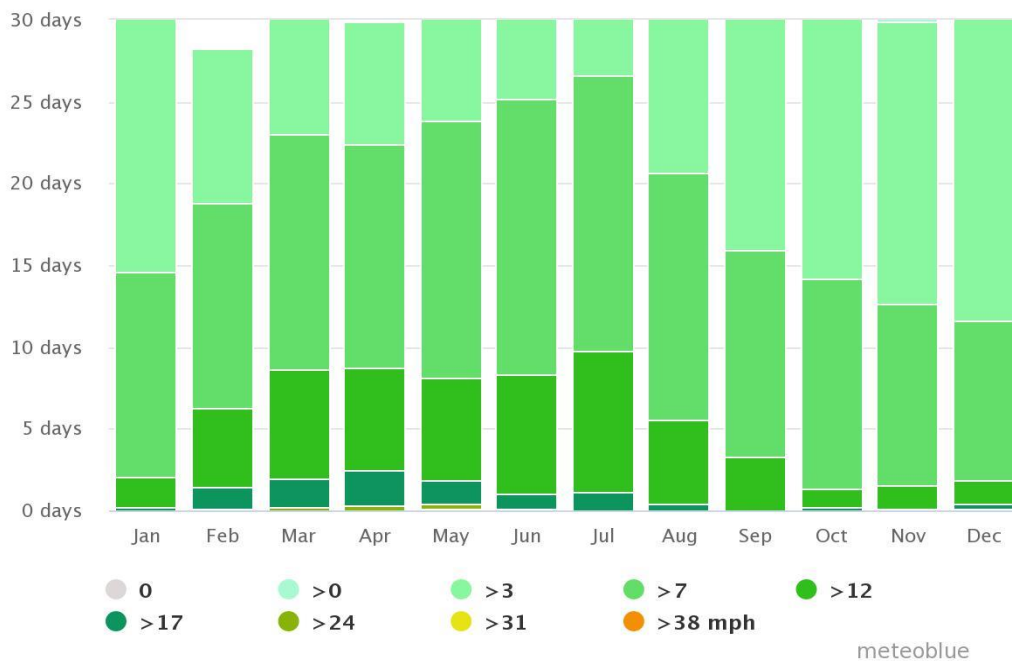

Figure 8: Annual average wind speed in Sheikhupura
(<https://www.worldweatheronline.com>)

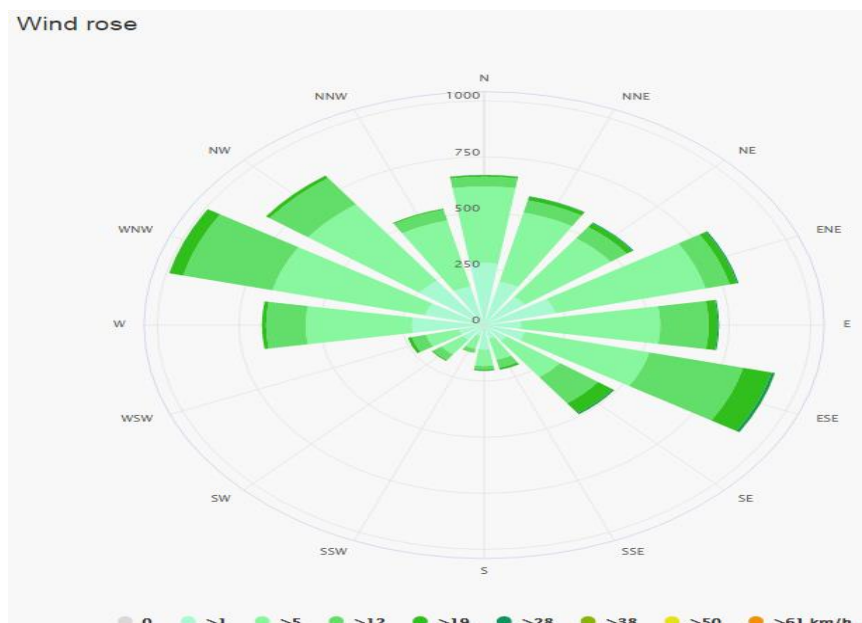

Figure 9: Wind Rose diagram of Sheikhpura

The wind rose for Sheikhpura shows how many hours per year the wind blows from the indicated direction. Example SW: Wind is blowing from South-West (SW) to North-East (NE).

4.5 Ecological Environment

Sheikhpura is enriched with the presence of natural flora and fauna, although with the growing population and development activities, the presence of some has been somewhat affected. They are discussed in detail below.

4.5.1 Aquatic Flora & Fauna

No aquatic ecosystem (i.e. canal, stream, river or pond) observed within or around the study area, which omits the possibility of any kind of aquatic species that may be harmed due to the establishment of proposed project.

4.5.2 Flora

The project is located in industrial area. The project site has no vegetative cover, hence, no trees or vegetation will be removed. The dominant tree species in study area include; Eucalyptus, Neem, and Kikar. The crops present around project site include wheat, sugarcane and common grass. The nomenclature including common, English, local and botanical names of the flora found in the study area are presented in Table

Table 4: Flora of the Study Site

S#	Common Name	Scientific Name
1	Neem	<i>Azadirachta indica</i>
2	Kikar	<i>Vachellia nilotica</i>
3	Safeda	<i>Eucalyptus globulus</i>

4.8.3 Fauna

For study of fauna in the project area, field guides and books were consulted. On the other hand field observations were conducted along with the interviews of local community members about the fauna of the area. The equipment used in field included cameras, binoculars and GPS device (wherever required). It is important to note that there is a number of factors which can change the findings of such survey. It may be pointed out that the pattern of seasonal migration of small birds varies depending upon each specie. During the construction activity in project area, no important biological feature will be damaged or disturbed as the project falls in industrial area.

The fauna commonly found in District Sheikhpura includes; Hares, Falcon, Eagle, Quail, Starling, Jungle Pigeon, Russian Sparrow, Doves, King Fisher, Parrot, Crow and Local Sparrow.

Commonly found mammals in the area include; dogs, cats, horses, house-rats, squirrels, porcupines and bats. However, Small Indian Mongoose and Indian Palm Squirrel are also found in the District Sheikhpura.

Table 5: Mammals in Study Area

S#	Common Name	Scientific Name
1	Rat	<i>Rattus</i>
2	Bat	<i>Chiroptera</i>
3	Small Indian Mongoose	<i>Herpestes javanicus</i>
4	Indian Palm Squirrel	<i>Funambulus palmarum</i>
5	Porcupines	<i>Erethizon dorsatum</i>
6	Squirrels	<i>Sciuridae</i>

The commonly found bird's species include; House Sparrow, Crow and some of them are mentioned below with scientific names.

In District Sheikhpura reptiles such as Snakes (Cobra and Kraits), Spiny Tailed Lizard and Fringed Toed Lizard are common in the tract, but cases of snake bites are very rare, as these reptiles have been either killed by expanding urbanization or they have moved away.

Table 6: Birds in Study Area

S#	Common Name	Scientific Name
1	House Sparrow	<i>Passer domesticus</i>
2	House Crow	<i>Corvus splendens</i>
3	Pigeon	<i>Columbidae</i>
4	Bulbul	<i>Pycno notidae</i>
5	Teetar	<i>Francolinus francolinus</i>

6	Parrot	<i>Psittaci forms</i>
7	Titodi	<i>Vanellus indicus</i>

Table 7: Reptiles in the Study Area

S#	Common Name	Scientific Name
1	Snake	<i>Serpentes</i>
2	Spiny Tailed Lizard	<i>Uromastix hardwickii</i>
3	Fingered Toed Lizard	<i>Acanthodactylus cantoris</i>
4	Earthworm	<i>Lumbricina</i>

The amphibians commonly seen around the project area, especially during the rainy season includes;

Table 8: Amphibians in the Study Area

S#	Common Name	Scientific Name
1	Common Frog	<i>Rana temporaria</i>
2	Indus Valley Toad	<i>Bufo stomaticus</i>

A large number of insects are present due to open fields in the project site. Few of these insects are known to cause diseases in local population. Following is a list of commonly observed insects at the site:

Table 9: Insects in Study Area

S#	Common Name	Scientific Name
1	Black Ants	<i>Paratracheaiognicornis</i>
2	Dragon Fly	<i>Dragon Fly</i>
3	House Flies	<i>Musca domestica</i>
4	Butter Flies	<i>Parnassiusbalucha</i>
5	Honey Bees	<i>Apismellifera</i>
6	Wasps	<i>Anagyrus pseudococci</i>
7	Grasshopper	<i>Melanoplus differentialis</i>
8	Mosquito	<i>Anophlese sp.</i>

No endangered species are found at the site. The area has not been identified as ecologically sensitive area by wildlife department.

4.8.6 Water Resource

The main source of the water consumption is the ground water which is being pumped from 200 ft borehole and its being used in the study area for domestic purposes. To check the quality of the water in

the area, ground water was collected and analyzed. The ground water was collected from bore hole adjacent to the project area.

4.9 Socio-Economic Resources

This section provides collective information about the existing socio-economic and environmental condition of the project area within the AOI. The different types of socio-economic aspects were covered such as demographic profile, occupation, education and health facilities. This data helped in identifying major interventions for the development of Environmental Management and Monitoring Plan (EMMP). The study also helped to assess the positive or adverse impacts on local community.

4.10 Socio-Economic Profile of Study Area

This topic provides an overview of the baseline information relating to the socio-economic environment of the project area and the AOI. The socio-economic study gives information about the demographic profile, occupation, education and health facilities in the project area.

4.11 Demographic Profile

The Demographic Studies are the major source of any city's Socio-Economic profile. Demographic Studies relate to population. Population studies are extremely important from Town Planning point of view. Until and unless we know about population in detail, we cannot do successful planning. All aspects of population, such as sex-age composition, trend of migration, social, cultural, political, economic and administrative works, values and facilities have to be related to planning considerations and decisions. Individuals are the raw material of society; therefore, society is directly affected by size, growth, composition and distribution of its individuals. The term population refers to the number of individuals living within a geographical area at a given time.

Different community individuals in the vicinity of the project area have different family sizes depending upon their living setups. Average family size is however 5-7 individuals per family with 1-2 earning hands per family.

4.11.1 Health Facilities

As the project site is in an Industrial zone. DHQ Hospital Faisalabad is located at the distance of approx. 16 Km radius. Some other private health center is present as Villages area present in the vicinity of the project site.

4.11.2 Educational Facilities

As the project site is not located in any residential area. However, the villages located around project site have few governments primary schools.

4.11.4 Demographic Characteristics of the Population

The field survey (including interviews, focus group discussions, census, and area profile) was carried out to collect the socioeconomic data from the project affected people as well as other general population to

accomplish the baseline information, which will provide the basis for subsequent monitoring and evaluation studies.

The demographic features include the information on household’s profile, gender composition, occupations, and literacy status of the population residing in the project area. The information relating to the demographic profile of the people in the project area are described below.

4.11.5 Family Size

Based on the field survey of local population, the average family size computed to be 5-6.

4.11.6 Age Groups

Ages of the consulted population were also recorded. The people interviewed for the socio-economic assessment belongs to different age groups i.e. 20-35 years, 36-45 years, 46-55 years, and 56 years and above.

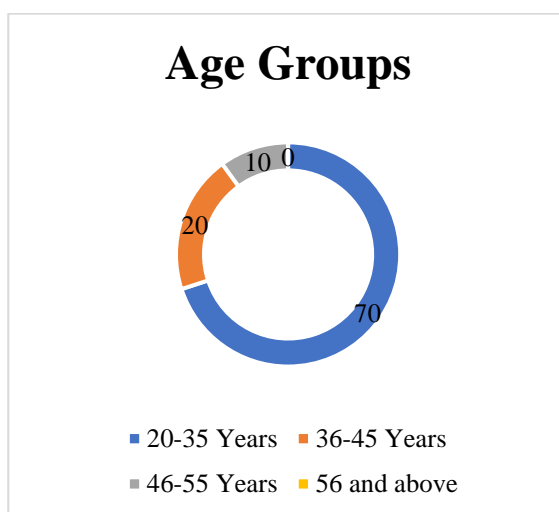

Figure 10: Consulted age groups in the area near project site

4.11.7 Occupation of Respondents

Majority of the respondents (55%) are attached with agriculture, 20% shopkeepers and remaining 15% are labors. During survey, efforts were made to interact with people representing all walks of life. The detailed graphic representation of occupational status is given below:

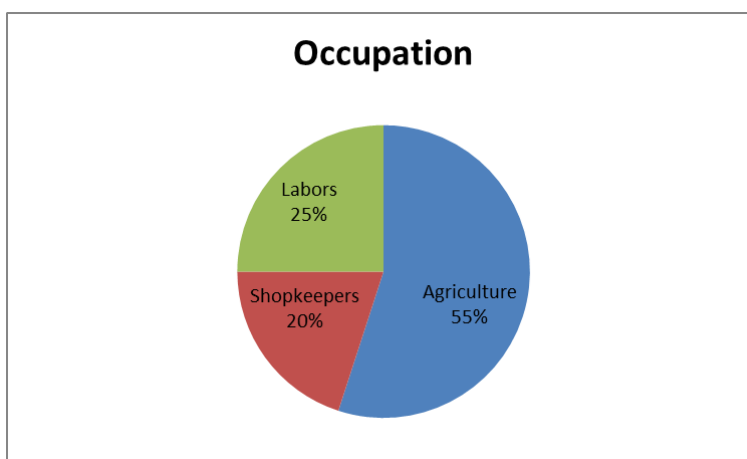

Figure 11: Occupation of Respondents

4.11.8 Literacy Rate

From survey results, it was found that 75 % of the studied population was illiterate, 15% was up to primary level, 10% studied up to middle level.

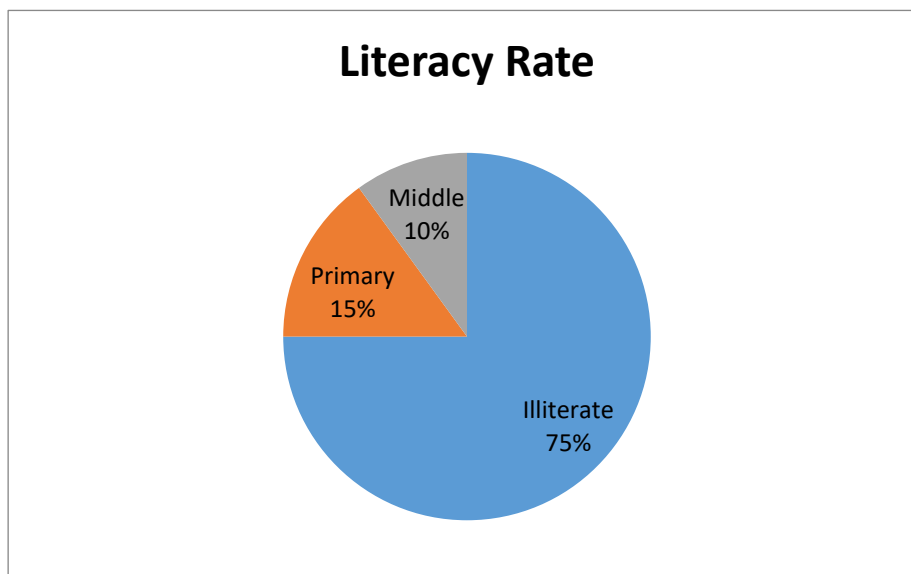

Figure 12: Literacy Rate

4.11.9 Common Diseases

According to the survey the common disease recorded in the project area is Hepatitis.

4.11.10 Cultural, Religious & Other Structures

No cultural, religious and other structures are present in the close proximity of the project area that needs to be relocated. Villages present around the project site have mosques and imam bargah.

4.12 Lab Reports of Environmental Analysis

Testing of different parameters was done from a certified laboratory named SEAL to check the quality of different environmental parameters. The copy of the lab reports of these parameters (ambient air analysis, water quality analysis and noise) is attached at Annexure of this EIA Report.

4.13 Suitability of Site:

Comprising all assessment of above baseline data there will be no significant ecological/ environmental impact expected in and around the present selected project site, hence it is suitable for the proposed project.

Chapter 5. IMPACT ASSESSMENT METHODOLOGY

This section discusses the project's potential environmental impact on the area's geomorphology, soil, water resources, air, biological resources and socioeconomic condition and, where applicable, identifies mitigation measures that will reduce, if not eliminate, its adverse impact. The assessment carried out in this section is based on potential impacts on overall environmental receptors within the project area.

5.1 Objectives

The objective of screening is identification of the adverse as well as beneficial impacts and then mitigating the effect of adverse impacts up to acceptable limits or within PEQS. Following are the objectives of screening out all significant environmental and social impacts:

- To find different alternatives and ways of carrying out the project activities which may cause adverse impacts.
- To enhance the Environmental and Social benefits of project
- To avoid, minimize and remediate adverse impacts.
- To ensure that residual adverse impacts are kept within acceptable limits.

In the sub-sections below the impact's assessment methodology for the establishment of Marhaba LPG Traders (PVT) Limited (LPG Storage and Filling Station) located in Sheikhpura has been defined. It includes the magnitude, the extent of the impact and the nature of the anticipated impact.

5.2 Methodology

This Section discusses the project's potential environmental impact of establishment of LPG Storage & Filling Plant on the area's geomorphology, soil, water resources, air resource, biological resources, and socioeconomic condition and, where applicable, identifies mitigation measures that will reduce, if not eliminate, its adverse impact. The assessment carried out in the sub-sections below is based on potential impacts on overall environmental receptors within the project area. Impacts are evaluated based on magnitude, immediacy and sustainability. Evaluation criteria are as follows:

5.2.1 Magnitude

The magnitude of the impacts associated with the establishment of the Marhaba LPG Traders (PVT) Limited, include the type of impact project commencement will cause to its immediate environment and social structure. It could be direct, indirect, and cumulative.

5.2.2 Immediacy

Immediacy of the impact focus on the following parameters:

- Temporal Extent (during operation)
- Spatial Extent (local or widespread)

5.2.3 Sustainability and Reversibility

Sustainability and reversibility of the impact focused on the following parameters:

- Mitigability (Fully/Partially)
- Monitoring (Fully/Partially)

5.3 Purpose of Mitigation Measure

The basic purpose of mitigation measures is to reduce the impacts of the establishment of Marhaba LPG Traders (PVT) Limited on the socio-environment up to the maximum possible extent. The mitigation measures are suggested based on the following parameters:

5.3.1 What is the problem?

The proposed project is the establishment of an LPG Storage & Filling Plant. The study area is leveled and Self-developed commercial. In addition, to the noise and fugitive dust emissions during the development phase solid waste also requires proper management. The major impact associated with the operation of building includes wastewater and the management of the solid waste.

5.3.2 When problem will occur and when it should be addressed?

The impacts from the establishment of LPG Storage & Filling Plant will occur during the construction and operation due to the civil work involved and the processes involved in activity. These issues include noise generation, fugitive dust emissions, solid waste management, wastewater disposal, top-soil removal, Health and Safety issues and change in the geographic features of the area. These all problems should be addressed on-site where they are being generated, to avoid the residual or adverse impacts.

5.3.3 Where problem should be addressed?

The problem will be generated from site development and operation of the unit. So, it should be addressed on source i.e., at site within the same timeframe.

5.3.4 How the problem should be addressed?

Proper mitigations measures will be provided according to the nature of the impacts/problems.

5.3.5 Ways of Achieving Mitigation Measures?

Following ways will be adopted to reduce the impacts of the manufacturing unit:

5.3.6 Changing in Planning Design

There is no endangered and threatened species present in the project area. Moreover, there is not any human settlement or infra-structure that will be dislocated or dismantled due to the proposed project development. Hence, there is no need to change the design of project.

5.4 Improved Management and Monitoring Practices

The anticipated impacts had been reduced significantly by adopting better management activities, as it will be carried out for betterment of the society. While environmental monitoring will be conducted on the regular basis to keep the sources of the air pollution, wastewater generation, noise, and public nuisances in-check. Following practices that need to be adopted to reduce the impact significantly:

a. Compensation in Money Terms

Due to the installation of proposed project, the vegetation present on-site will be removed and the geography/landscape of the area will be changed on the permanent basis, however, there is no protected or environmentally sensitive area present within 10.0 km vicinity of the project that could be impacted. Hence, no compensation in the monetary terms will be required. However, for the removal of the one tree from the project area 3-5 trees will be planted as the compensation.

b. Replacement/Relocation/Rehabilitation

The proposed project site is located in Self-developed commercial land. No replacement, relocation and rehabilitation will be required for the commencement of the aforesaid project.

5.5 Impact Assessment Methodology

The impact assessment methodology for the establishment of Marhaba LPG Traders (PVT) Limited is given below:

5.6.1 Screening of Potential Impacts

Based on site visit, observation, brain storming, provided information and social interviews, significant impacts were anticipated and evaluated. Then qualitative and quantitative (where possible) assessment of these anticipated impacts is to be carried out.

5.6.2 Identification of Mitigation Measures

After anticipation and screening of significant impacts, certain mitigation measures are to be provided in order to enhance benefits of project and reducing impacts. These measures can be classified as:

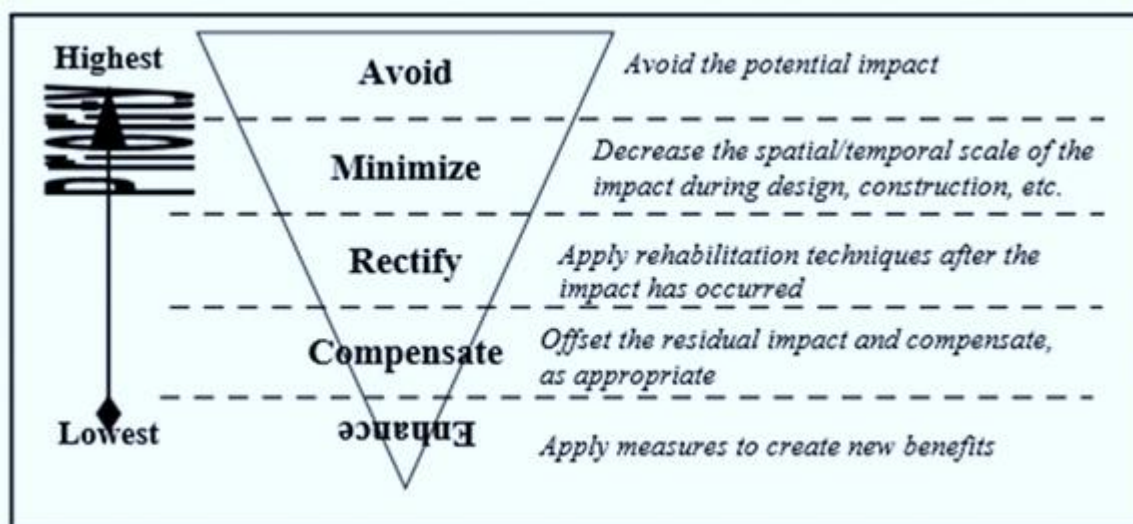

Figure 13: Hierarchy of Mitigations

5.6.3 Evaluation of the Residual Impacts

Incorporation of suggested mitigation measures may reduce the magnitude of the environmental impacts of the project but sometimes, it may fail in bringing them within the acceptable limits. This step refers to the identification of the anticipated remaining impacts after mitigation measures have been applied.

5.6.4 Identification of Monitoring Requirements

The last step in the assessment process is the identification of minimum monitoring requirements. The scope and frequency of monitoring depends on the residual impacts. The purpose of the monitoring is to confirm that the impact is within the prescribed limits and to provide timely information if acceptable limits are being breached.

5.6 Impact Evaluation

Impact screening checklist and project impact evaluation matrix have been developed to evaluate the potential impacts of the establishment of Marhaba LPG Traders (PVT) Limited on the basis of set procedures as given in the environmental guidelines by Punjab EPA.

5.6.1 Methodology for Impact Evaluation

These tools have been used to identify the significance and magnitude of the impact as well as the nature, reversibility, and extent:

1. An Impact Screening Checklist
2. Project Impact Evaluation Matrix

Following is given a brief description of assessment tools:

a) Impact Screening Checklist

The impact screening checklist is developed to screen out the potentially insignificant environmental and social impacts from the potentially significant adverse environmental and social impacts during planning & designing, and operational phases of the project. The objective of the impact screening process is to assess the significance of the issues related to the air, water, noise, soil, transportation, communication, the hazards, and external constraints. The positive and adverse impacts of the project during planning & designing, and operational phases are identified based on their duration, location, frequency, extent, significance and reversibility. Each activity impacts on various environmental parameters are given below:

Table 10: Impact Screening Checklist

Sr#	Environmental Component	Impact Characteristics												
		Duration		Location		Frequency		Extent		Significance			Reversibility	
		Long	Short	Direct	Indirect	Cont.	Intermittent	Wide	Local	Large	Moderate	Minor	Rev.	Irrev.
Beneficial Impacts														
1	Employment Opportunity	<input checked="" type="checkbox"/>		<input checked="" type="checkbox"/>		<input checked="" type="checkbox"/>			<input checked="" type="checkbox"/>		<input checked="" type="checkbox"/>		<input checked="" type="checkbox"/>	
2	Availability of Raw-Material	<input checked="" type="checkbox"/>		<input checked="" type="checkbox"/>		<input checked="" type="checkbox"/>			<input checked="" type="checkbox"/>		<input checked="" type="checkbox"/>		<input checked="" type="checkbox"/>	
3	Appreciation in Land Value	<input checked="" type="checkbox"/>			<input checked="" type="checkbox"/>	<input checked="" type="checkbox"/>			<input checked="" type="checkbox"/>			<input checked="" type="checkbox"/>		<input checked="" type="checkbox"/>
4	Energy Availability	<input checked="" type="checkbox"/>		<input checked="" type="checkbox"/>		<input checked="" type="checkbox"/>			<input checked="" type="checkbox"/>		<input checked="" type="checkbox"/>		<input checked="" type="checkbox"/>	
Adverse Impacts														
1	Air Pollution		<input checked="" type="checkbox"/>	<input checked="" type="checkbox"/>			<input checked="" type="checkbox"/>		<input checked="" type="checkbox"/>			<input checked="" type="checkbox"/>	<input checked="" type="checkbox"/>	
2	Wastewater		<input checked="" type="checkbox"/>	<input checked="" type="checkbox"/>		<input checked="" type="checkbox"/>			<input checked="" type="checkbox"/>			<input checked="" type="checkbox"/>		<input checked="" type="checkbox"/>
3	Solid Waste and By-Products	<input checked="" type="checkbox"/>		<input checked="" type="checkbox"/>		<input checked="" type="checkbox"/>			<input checked="" type="checkbox"/>		<input checked="" type="checkbox"/>			<input checked="" type="checkbox"/>
4	Health and Safety		<input checked="" type="checkbox"/>		<input checked="" type="checkbox"/>		<input checked="" type="checkbox"/>		<input checked="" type="checkbox"/>			<input checked="" type="checkbox"/>	<input checked="" type="checkbox"/>	
5	Chemical Hazards		<input checked="" type="checkbox"/>	<input checked="" type="checkbox"/>		<input checked="" type="checkbox"/>			<input checked="" type="checkbox"/>		<input checked="" type="checkbox"/>		<input checked="" type="checkbox"/>	
6	Physical Hazards		<input checked="" type="checkbox"/>	<input checked="" type="checkbox"/>			<input checked="" type="checkbox"/>		<input checked="" type="checkbox"/>			<input checked="" type="checkbox"/>		<input checked="" type="checkbox"/>
7	Security Risks		<input checked="" type="checkbox"/>		<input checked="" type="checkbox"/>		<input checked="" type="checkbox"/>		<input checked="" type="checkbox"/>		<input checked="" type="checkbox"/>		<input checked="" type="checkbox"/>	

b) Project Impact Evaluation Matrix

The Project Impact Evaluation Matrix was developed by placing different environmental parameters that are likely to be affected by the proposed project actions, grouped into categories i.e., physical, ecological and socio-economic environment. For the impact assessment risk assessment methodology was used. Moreover, the risk assessment was done on the basis of project phases (planning & designing, and operation). A Project Impact Evaluation Matrix is attached as Table below:

Table 11: Impact Evaluation Matrix

Environmental Parameters	Impact Assessment during operational Phase
A: Physical	
Land Resources	
Soil Erosion and Contamination	0
Transportation	-1t
Solid Waste and By-Products	-1p
Land Use	NA
Air Resources	
Noise Pollution	-1t
Air Pollution	-1p
Dust Emissions	-1t
Water Resources	
Ground Water	-1p
Surface Water	NA
Wastewater	-2p
B : Ecological	
Flora	
Tree Cutting	+1p
Fauna	
Terrestrial Fauna	+1p
C: Socio-Economic	
Employment Opportunities	+3p
Land Value Appreciation	+2t
Availability of Local Raw-Material	+2p
Economic Uplift	+3p
D: Hazards	
Physical Hazards	-1p
Chemical Hazards	-1p
Health and Safety	-1p
<i>Legends: 1= Low; 2= Medium; 3= High; 4= Extremely High; NA= Not Applicable; t= Temporary; p= Permanent; app= Applicable; 0= Negligible</i>	

CHAPTER 6. SCREENING OF IMPACTS AND THEIR MITIGATION MEASURE

This Chapter identifies the potential impacts (positive and adverse) on the physical, biological and socio-economic environment of project area due to the establishment of Marhaba LPG Traders (PVT) Limited. It also identifies measures that will help to mitigate the adverse environmental impacts and will enhance positive impacts of the project. Impacts are assessed by analyzing their magnitude and sensitivity, which is a legal requirement.

6.1 Impact and Mitigation Management

Purpose of mitigation is to evade, reduce or balance the expected antagonistic effects in suitable way and to integrate these for devising environmental management strategy or plan. At every stage of the project, mitigation plan for all the adverse impacts should be predicted to find out the best alternative.

The objectives of mitigation are to:

- ⇒ Invention of best substitution, better alternatives, and ways to reduce the adverse environmental and social impacts on the surroundings.
- ⇒ To improve the environmental and societal payback of the project
- ⇒ To prevaricate, remedy or reduce, pro-vocative impacts.
- ⇒ To certify that remaining negative influences are kept within permissible limits.

In this part of the EIA Report, several complications including cleanliness, environmental health and safety, societal and environmental managing and inspection, industrial vulnerability, tools, and apparatuses and during operational activities, influx of workers and procurement of land have been deeply elaborated.

6.1.1 Approaches for Mitigation Measures

Following approaches may be used to mitigate the impacts of the project:

Table 12: Approaches for Mitigation Measures

Avoid: Change of route or site details, to avoid damage
Replace: Regenerate similar habitat of equivalent ecological value in different location
Reduce: Filters, precipitators, noise barriers, dust, enclosures, visual screening, wildlife corridors and changed time of activities to reduce the impact
Restore: Site restoration at the end of the operational activities
Compensate: Relocation of displaced communities, facilities for the affected communities, financial compensation for the affected individuals, etc.

6.2 Expected Positive Impacts

Following are the expected outcomes of the establishment of the Marhaba LPG Traders (PVT) Limited:

6.2.1 Increase in Employment Opportunities during Construction Phase

Due to the establishment of LPG Storage & Auto Filling Plant in Lahore the employment opportunity will be enhanced. It will include technical and non-technical staff. Locals will also have the opportunity to

diversify their income by being employed. Hence, there will be an increased employment opportunity for the local people which will have a positive impact on the socio-economic status of the area.

6.2.2 Efficient and Economic Residential Availability

In addition to all these benefits, the project will result in the general economic and social uplift in the areas of the Lahore.

6.3 Adverse Impacts and Mitigation Measures

This section identifies the potentially significant and insignificant adverse environmental and social impacts anticipated during the operation phase for the establishment of Marhaba LPGTraders (PVT) Limited. Appropriate mitigation and management measures, where applicable, have also been suggested to reduce the severity of the anticipated impact up to the extent possible.

6.4 Impacts Due to Project Location

The proponent has selected the site owing to the following reasons:

- ✚ The site is undisputed and allotted to the proponent
- ✚ The site has the potential to store the required amount of the raw-material
- ✚ There is no community or human settlement present on-site
- ✚ There is no fauna or flora belonging to an endangered species present on-site
- ✚ The site has accessible through road network i.e., connected to the main road via access roads
- ✚ There is no ecologically sensitive or declared protected area (PA) like; Reserved Forest, Fish Hatcheries, Territorial Waters, Wildlife or Game Reserves. Moreover, there is no socio-cultural significant structure (historical or archaeological site or religious structures; Masjid, temples, etc.) located within safe radius of the selected site that could be impacted.

It can be concluded in view of these reasons that the selected site is best suited for the project, and will not pose any adverse impact or threat on any component of the environment

6.4.1 Relocation of People

Currently, there are no infringements on the project site that may be affected therefore relocation exercises are not required.

6.4.2 Loss of Vegetation

Considering the scale of the project and commonly found flora and fauna within the project influence area, no significant adverse effects are envisaged on the ecology of the area.

6.4.3 Shifting of Utilities.

There will not be any shifting of existing utilities such as water supply pipelines, sewers, electrical lines, etc. due to the proposed project.

6.4.4 Impact on Archaeological/Cultural Property

Within the project influence area there are no significant archaeological properties, hence no impact in this area is anticipated.

6.5 Impacts Due to Project Design

During design phase most of the impacts will disturb the physical environment as well as the parameters associated with the social structure of the society.

6.5.1 Location

While citing a project, care should be taken to minimize the adverse impact of the facility on immediate neighborhood as well as distant places. The application of good and sound citing criteria is often the best and first strategy to minimize the environmental and social impacts that can be caused by a project. The Proposed site is undisputed open rural land and under the ownership of the Proponent.

Easy road access, no settlements in close vicinity, no archeological or cultural resources to be dismantled or relocated, and no ecologically sensitive or declared protected area existing on proposed site that favors the point of no impact due to project location.

Mitigation

No mitigation measure is required as the proposed project will not have any adverse impacts on its surroundings due to significant distances from sensitive receptors.

6.5.2 Designing

At the design phase, no considerable impact will occur on land, soil, topography, ground water, and on people of the area. However, in pre-construction phase a management system should be provided at design level so impacts can be reduced. Design of the proposed plant will adhere to all standard technical requirements in order to avoid adverse impacts on environment and human health.

Mitigation

The Proponent intends to construct the unit on modern lines, meeting International Standards, with incorporation of modern technology. The design, if maintained and operated in an environment-friendly manner, is expected to cast positive impact on the Environment and will not pose any adverse impact or threat on any component of the Environment.

6.6 Impacts Due to Project Construction

Project constructions typically change the natural environment, creating negative impacts in some cases. These are short-term impacts of low magnitude, which are easily managed.

The Environmental and Socio-Economic Impacts associated with the construction activities of the plant are the following:

- Construction Noise
- Dust Emission During Construction
- Change of Land Use
- Water Sourcing
- Vehicle and Equipment Exhaust
- Soil Contamination
- Camp Effluent

- Hazardous and Non-Hazardous Waste Management
- Disturbance to Wildlife
- Socioeconomic Impact
- Community and worker's Safety
- Traffic Disturbance
- Local Employment Conflicts
- Archeological Resources
- Project and Community Interface

6.6.1 IMPACTS ON PHYSICAL ENVIRONMENT

6.6.1.1 Effect on Geomorphology and soil

Potential Impacts

Spills of chemicals and fuel during handling, transportation and storage may result in contamination of soil at the construction site. During a typical construction project spill of fuel, lubricants, and chemicals can take place. As a result, contamination of soil will occur, significance will depend on the nature of material, location of spill and quantity of spill.

The likely impacts of these activities may include:

- Physical scarring of the landscape
- Increased risk of land slippage
- Erosion from road sides, well pads and sloped surface as well as soil and slit from the cleared area, results in increased sediment load in surface run off.
- Soil contamination

Impact Assessment

Soil contamination may occur due to spillage and leakage of fuels, and other chemicals. This possibility of impact is more at fuel and chemical storage areas at campsites, vehicles and machinery used in the field and areas of vehicle fueling and maintenance.

There are no visible signs of any adverse impacts on the soils and to avoid such conditions following mitigation measures are provided and will be followed

Mitigation Measures

- Spill Prevention and Response Plan for storage, use and transfer of fuel and hazardous materials should be prepared.
- Workers should be trained on spill prevention and response plan.
- Thick Plantation is recommended after completion of project to minimize land slippage and soil erosion impacts.
- Fuels, lubricants, and chemicals should be stored in covered areas, underlain with impervious lining
- Maintenance and washing of vehicles and equipment should be carried out at designated areas
- Any hard surface or tarpaulin should be spread on area to prevent soil contamination.
- Regular inspections should be carried out to detect leakages in construction vehicles and equipment

- Appropriate arrangements, including shovels, plastic bags and absorbent materials, should be available near fuel storage areas.

Residual impacts

No residual impact to soil will be caused provided the above-mentioned measures are implemented properly.

Monitoring requirement

- Regular inspection of soil of the project area should be undertaken
- Document all related accidents of spillage to take corrective actions and to avoid reoccurrence.

6.6.1.2 Water Quality

Potential impacts

The quality of surface and groundwater supplies may deteriorate if pollutants mix with surface runoff during rain are carried to water resources in the vicinity, or if pollutants leach into the ground.

The storage and handling of fuels and lubricants may also contaminate surface and groundwater resources, if there are spillages that wash into surrounding areas or seep into the ground.

Improper disposal of domestic effluent from the camp may result in contamination of soil and water and become a health hazard. A significant impact on the environment will be interpreted if the wastewater discharged is not in compliance with the Punjab Environmental Quality Standards for municipal effluent.

Impact Assessment

A significant amount of sediment may get washed into fields and watercourses if it rains during the construction period; however, the impact is not expected to be significant. Potential sources of pollution in such cases may include:

- Domestic waste (sanitary and kitchen discharge)
- Oil and grease from vehicles
- Sediments from altered land surfaces (campsites)
- Stored Fuel, and other chemicals

Mitigation Measures

- Lined Septic tanks will be provided
- Fuels and lubricants will be stored in areas with impervious floors
- Proper drainage will be provided to construction camp and construction site.

Residual Impacts

Implementation of the proposed mitigation measures is not likely to leave any significant impact on the soil or surrounding land.

Monitoring requirement

Periodic monitoring will include:

- Discharge rate of wastewater
- Chemical analysis of the wastewater

6.6.1.3 Water Use

The water during the construction activity will be required for the domestic water consumption and for the construction activities including sprinkling of water for dust suppression.

Potential impacts

The extraction of water for the construction may affect the water availability for other water users. An adverse impact on the water resources will be interpreted if it is established that the water extraction during construction has directly affected the ability of the community to meet their water needs

Mitigation measures

Following mitigation measures should be incorporated to minimize any impacts;

- Water conservation program will be initiated to Prevent Wastage of water.

6.6.1.4 Dust Emissions

Dust generated during construction activities can be substantial. Dust emission from construction sites is a concern particularly if the site is near residential areas. Dust or the equivalent technical term 'particulate matter,' is generally defined as any airborne finely divided solid or liquid material up to the size of about 100 microns (micrometers or one millionth of a meter).

Potential Impacts

Particulate matter emitted during construction activities can result in deterioration of ambient air quality in the vicinity of the source and be a nuisance to the communities and plant workers. The main health hazards are the particles smaller than 10 microns (designated as 'PM₁₀') as they are Respirable. Larger particles also tend to settle rapidly and often do not reach receptors. In cases where they reach the receptors, the dust is considered a nuisance as it may spoil property and affect visibility. A significant effect on the environment will be interpreted if there is an increase in visible dust beyond the boundaries of the power plant due to activities undertaken at the plant site, or the dust affects local property or results in complaints from the community.

Impact Assessment

Potential sources of particulate matter emission during construction activities include earthworks (dirt or debris pushing and grading), exposed surfaces, exposed storage piles, truck dumping, hauling, vehicle movement on unpaved roads, and concrete mixing and matching. The quantity of dust that will be generated on a particular day will depend on the magnitude and nature of activity and the atmospheric conditions prevailing on the day.

Mitigation measures

The most effective means of reducing the dust emission is wet suppression. Watering exposed surfaces and soil with adequate frequency to keep soil moist at all times can reduce the total dust emission from the project by as much as 75%

Dust emission from soil piles and aggregate storage stockpiles will be reduced by covering the piles, for example with tarpaulin or thick plastic sheet.

Good quality (low-sulfur) fuel will be used for vehicle and machinery

Construction materials that are susceptible to dust formation will be transported only in securely covered trucks to prevent dust emission during transportation.

Provision of dust respirators to equipment operators who are exposed to dust while operating their equipment.

Tree planting on open and disturbed areas which will not be used by the operations.

Residual Impacts

The effects of the dust nuisance are temporary with no long-lasting impact expected after the completion of the construction.

Monitoring requirements

- Dust emission will be visually monitored
- Ambient air quality will be checked near or at project site.

6.6.1.5 Noise

Potential issues

Depending on the Construction Equipment used and its distance from the receptors, the community and the unit workers may typically be exposed to intermittent and variable noise levels. During the day such noise results in general annoyance and can interfere with sleep during the night. The potential noise related issues during construction is the disturbance to workers and the surrounding communities due to construction machinery operation on the site.

Impact Assessment

The potential sources of significant noise during the construction period include the construction machinery, construction related traffic. The noise will be maximum during the day time when construction activities are ongoing.

Mitigation Measures

- Reduce equipment noise at source by proper design, maintenance and repair of construction machinery and equipment
- Minimize noise from vehicles by use of proper silencers and mufflers
- Use noise-abating devices wherever needed and practicable.
- The movement of vehicle should be restricted during night time.
- Providing workers with noise related PPE's
- Planting of trees that could serve as sound buffers.
- Noise barriers must be put in on and around the project boundary
- Hauling trucks shall be operated at low speed to minimize vibration, promote road safety, etc

Monitoring requirement

Monitoring will be done on regular basis to avoid increase in noise beyond PEQ's

6.6.2 IMPACTS ON BIOLOGICAL ENVIRONMENT

6.6.1.1 Flora

The project area is an Open area owned by Proponent. As such there's not any natural vegetation on the project site. So, there is no possibility of vegetation loss. But Proponent has planned a Tree Plantation plan within the Project area.

6.6.1.2 Fauna

During the construction phase, there will be considerable human interventions in the project area which can potentially affect the wildlife resources of the project area. Following mitigation measures will be followed for prevention of accidents of wildlife and birds.

Mitigation

- A 'no-hunting, no trapping, no harassment' policy will be strictly enforced.
- Trading of wild animals or birds by project personnel will also be prohibited.
- Wildlife protection rules will be included in the Camp Rules
- Proper signs for birds protection will be placed

6.6.3 SOCIO-CULTURAL IMPACTS

6.6.2.1 Possible Displacement

As the site is open plot and resettlements and community are at a safe distance from site, so no displacement or relocation of people is expected.

6.6.2.2 Land Use

Proposed land is open land and it is going to be improved to commercial land, so its value will be increased, and positive land use will occur.

6.6.2.3 Induction of Labor

During the proposed project, unskilled, semi-skilled, and skilled labor will be employed for various jobs. All of this means that the proposed program will create job opportunities for the local community. Families close to the project activities expect an improvement in their quality of life and employment not equitably and judiciously distributed between the tribes of the project area will result in intertribal conflict.

Mitigation Measures

- All unskilled jobs will be provided to the local communities.
- Before project, the local communities and other stakeholders in the project area will be informed of the employment policy in place and the number of people that can be employed from the local communities.
- Local people closest to the project site (and therefore the most likely to be affected by project activities) will be given preference.

6.6.2.4 Community Health

People from the project area regularly travel to other cities, and thus cannot be considered isolated from the rest of the country. They are regularly exposed to illnesses common to urban populations and have similar levels of immunity. Workers will undergo medical examinations before being hired and will be

screened for communicable diseases. In addition, there will be very little contact between workers and local people. The project is therefore very unlikely to lead to an epidemic of any sort among local communities.

Mitigation Measures

The crew will undergo medical examinations before being hired and will be screened for communicable diseases. The project is therefore very unlikely to lead to an epidemic of any sort among local communities.

- All employees shall undergo regular check up with physician to ensure that they have good health.
- The proponent will provide regular medical practitioner for the regular checkup of the employees' health.
- Conduct free clinic and medical mission to regularly check the health condition of the residents of the community.

6.6.2.5 Safety

Potential Issues

Safety always remains an area of utmost concern in any occupational activity; construction being one. Not only workers but the people from surrounding communities on the roads adjacent to the site are at stake of safety risks as well.

The safety issue is that of traffic entering and leaving project site for transport of goods and materials. Worker's safety is also an issue because of machinery if they show carelessness.

Mitigation measures

To reduce the hazard, the following mitigation measures will be implemented:

- A stop sign will be put up on the access road
- A speed breaker will be constructed on the access road
- The speed limit for the access road will be kept low
- A public safety plan should be developed and displayed
- Community complaint register, and other mean should be adopted for the community to complain.
- All entry points into the construction area should be staffed 24 hour a day. People who are not related to the project should not be allowed inside.
- No machinery should be left unattended, particularly in the running condition.
- Nighttime driving of project vehicles should be limited.
- Drivers will be trained to drive slowly following traffic rules.

6.6.2.6 Interaction with Communities

There is expected to be very little interaction between crews and local communities, expect for the local people who are hired for the project.

Mitigation Measures

Proponent will strive to maintain contact with major stakeholders, particularly local communities, through all stages of project implementation. This is necessary to engender sense of community in the project

proponents and to ensure that the community's concerns are responded to at every stage. The purpose of such contact is to develop a relationship of trust with the local communities.

6.6.2.7 Archeological or Cultural Resources

It is possible that the project may damage structures, such as archaeological sites, houses, water wells and canals and water courses, owned and used by local people. No known sites of archeological or cultural value are known to exist near the proposed well site or along the access road. The project is therefore not expected to have any impact on archeological or cultural resources of the area.

Mitigation Measures

The following mitigation measures will be taken to reduce the impact on the area's cultural resources and infrastructure:

- All graveyards and shrines and other cultural sites in the vicinity of the project area will be identified before the survey.
- Communication will be established with the local spiritual leader and the communities to explain about the activities near the sites.

6.6.2.8 Security Risks

During construction phase a large number of workers will be hired including engineers and laborers. The increase in people to the area, as well as the periods where some construction workers are unemployed could lead to an increase in crime and violence in surrounding areas.

Mitigation measures

- Proper Security will be provided
- Security guards will be appointed

6.7 Impacts Due to Project Operation

During the operation phase, there will be impacts on the air, water, and land environment, as well as on socio-economic aspects. The following sub-sections present the impacts due to the operation of the proposed project.

The Environmental and Socio-Economic impacts associated with the operation phase of the power plant are following:

- Air Emissions
- Noise
- Wastewater
- Water Resources
- Waste Management
- Occupational Health and Safety

6.7.1 Water Consumption

The increased withdrawal of surface water for the Proposed Project may affect the water availability for the other users of the Project Area. A significant impact will be interpreted if water extracted for the project directly affects the ability of the community and other users to meet their water needs.

Impact Assessment

Water usage will be only domestic in nature.

Mitigation Measures

Water conservation program will be initiated in plant colony to prevent wastage of water.

6.7.2 Water Quality**Potential Impacts**

Water pollution is contamination of water by undesirable foreign matter. It impacts surface water and underground water. At the project site, there will be no wastewater generation during operational activity as project does not involve any processing and no water will be consumed during storage except domestic purposes. The discharge of effluent from unit will be only municipal.

Mitigation Measures

There will be no any industrial activity, so no wastewater will be generated, domestic wastewater will be treated by passing through septic tanks to soakage pit.

6.7.3 Soil Contamination

Leakage of petrol or diesel from tankers arriving on site during process of LPG station can cause soil contamination.

Mitigation Measures:

Ensure that vehicles are well tuned and have no leakage.

6.7.4 Air Quality

Project only involves storage and filling of LPG, not any industrial activity so there will be no emissions. Only dust will be generated during floor cleaning that will be controlled by water sprinkling. In case of leakage, broken down pipes, LPG could escape which will have certain impacts on workers. For this, Gas detectors will be provided. Further PPEs will also be provided to workers to cater this situation and ensure safety and health.

6.7.5 Noise and Vibration

Project only involves storage and filling of LPG, not any industrial activity so there will be no noise generation. Noise will only be generated during transportation, for this only those vehicles will be used that are properly tuned and maintained and are equipped with silencers. Also excessive use of horns will be avoided. Further tree plantation will be done as it acts as noise absorbers.

Residual Impacts

Implementation of the mitigation measures proposed above will result in negligible / no residual impact due to noise on surrounding environment.

Monitoring Requirements

During project operation, it should be ensured that the noise level at the project site does not exceed the prescribed limits.





6.7.6 Solid Waste Management

Potential Issues

The solid waste generated during the operational phase of Proposed Project can pose a health hazard, pollute the soil, surface and ground water if not manage properly. A significant impact will be interpreted if the waste management is not carried out properly; which may affect to health of workers, pollution of soil, surface or groundwater.

Impact Assessment:



Potential source of solid waste from operational activities include:

-  Office waste
-  Plastics
-  Rags
-  Paper

No significant impact on the environment is anticipated from solid waste generation at the project site as the generated solid waste comprise of a domestic waste and waste scrap mainly which would be sold to their respective dealers.

Mitigation Measures

Key elements of the Waste Management System will be the following:

-  Separate waste bins will be placed for different type of wastes
-  Records of all waste generated will be maintained. Quantities of waste disposed, recycled, or reused will be logged on a Waste Tracking Register.
-  Waste will be managed by solid waste management contractor.

Residual Impacts

Proper implementation of the mitigation measures will ensure that the residual impact from waste is minimum. Monitoring and inspection will be undertaken to ensure compliance and minimize any residual impact.

6.7.7 Emergency Response





Incidents and accidents may take place unexpectedly during project operations no matter how effective, strong and efficient the mitigation measures for all adverse impacts; especially the safety issues may be adopted. These may include;

- Fire hazard

6.7.8 FIRE HAZARD

During operational phase of the project, fire hazard poses a serious threat. Fire extinguisher details are mentioned on map.

Mitigation

-  Fire extinguishers should be properly maintained and checked periodically.
-  Adequate fire hydrant system should be installed.
-  Flammable materials should be prohibited in the premises.
-  Fire alarm systems should be maintained for detection and warning of fire.

- ✚ Pressure gauges should be checked monthly.
- ✚ Adequate training of workers on use of firefighting system to deal with the situation.
- ✚ Administration of the unit will make a proper evacuation plans for emergency escape from all halls.
- ✚ Emergency call service must be made available.
- ✚ Firefighting team must remain ready at all times.

6.8 Potential Environmental Enhancement Measures

6.8.1 Tree Plantation

Tree plantation within and outside the premises is a potential environmental enhancement measure. A large area will be reserved for tree plantation and among plants native flora like Peepal, Kikar, Dherak, Safeeda and Amaltas will be planted in the specified green zone which will have the maximum capacity to reduce noise pollution and tolerance index of these species are more than 10. Some floral species like roses and other ornamental evergreen plants will also be introduced in the lawn which will enhance aesthetic beauty. In addition, trees like Safeeda and Amaltas will be planted as boundary wall inside the lawn which will look like green wall. The proponent will also make arrangements for protection and maintenance of trees.

6.8.1 Facility Design

The introduction of an ecologically effective and efficient design of a facility is the environmental enhancement measures planned by the proponent to be incorporated into the design of the intended project.

6.9 Social Enhancement Measures

Following measures will be adopted to improve the socio-economic condition of the area:

6.9.1 Employment/Poverty Alleviation

The employment opportunities in the project area will be increased due to the establishment of LPG storage and filling unit of Marhaba LPG Traders (PVT) Limited. Limited at the aforesaid location. During establishment of the aforesaid facility un-skilled workers will be required as labors, sanitary workers and sweepers as well as for the skilled workers such as; accounts and managers to run the administration office local community will be considered on the priority basis. In totality, the overall economic conditions of the area will be improved due to the establishment of the aforesaid project.

6.9.2 Local Economy

The employment opportunities and/or income sources generated by the project construction and operation will be long term in nature. These will be enhanced once the construction phase is completed. The local economy will experience a slight boom during development and operational period.

CHAPTER 7. ENVIRONMENTAL MANAGEMENT AND MONITORING PLANS

This chapter summarizes the various mitigation measures as outlined previously in this EIA Report that will be implemented during the construction, operational and decommissioning stages of project. It does not discuss further the mitigation measures which have been adopted within the design and planning of the project, as these are comprehensively covered in previous section of this EIA Report.

Outline and key features of the EMMP for operations phase is presented. As per the environmental legislation in Pakistan, the EMMP for the operations phase, along with other documents, is to be submitted to the environmental protection agency to obtain confirmation for compliance and Environmental Approval for project operation. Even after implementation of the suggested mitigation measures, the impact may remain significant, and require monitoring.

7.1 Objectives

An Environmental Monitoring Plan was outlined alongside Environmental Management Plan to ensure all the corrective actions to counter adverse impacts which gives a detailed EMMP. The EMMP will serve as a principal execution module of the project that would not only mitigate adverse environmental impacts during the construction and the operational phase of the project but also ensures that environmental standards and good in-housekeeping are being practiced. Continuous environmental monitoring is exercised to ensure that preventive measures are in place and effective to sustain environmental integrity.

The key objectives of EMMP are:

- To outline functions and responsibilities of persons
- To state and implement standards and guidelines which are required under environmental legislations particular in context to the Project.
- To facilitate the implementation of the mitigation measures by providing the technical details of each Project's impact and proposing implementation schedule of the proposed mitigation measures
- Define a monitoring mechanism and identify monitoring parameters to ensure that all proposed mitigation measures are completely and effectively implemented.
- Identify the resources required to implement the EMMP and outline corresponding financing arrangements.

7.2 Management Approach

The organizational roles and responsibilities of the key players are summarized below:

7.2.1 Proponent

The project proponent will undertake overall responsibility for compliance with the EMMP. The concerned departments will carry out verification checks to ensure that the contractors are effectively implementing their environmental and social requirements.

7.2.2 Contractors

The contractors will implement most environmental and social mitigation measures. The contractors will carry out field activities as part of the project. The contractors are subject to certain liabilities under the environmental laws of the country, and under its contract with proponent.

7.3 Components of EMMP

The EMMP consists of the following:

- ⇒ Institutional arrangements
- ⇒ Mitigation plan to reduce the severity of associated impacts.
- ⇒ Monitoring plan to monitor the impacts and their severity.
- ⇒ Environmental and social trainings to raise awareness.

7.3.1 Remedial and Mitigation Measures

The objective of remedial and mitigation measures in any project is to identify practices, technologies or activities that would prevent, minimize, or mitigate all significant negativities that are likely to occur due to the proposed project.

7.4 Environmental Management and Monitoring Framework

The purpose of the environmental management and monitoring framework is to facilitate the implementation of environmental commitments, included in the environmental impact assessment. The proponent is committed for the protection of the environment and to the sustainable management of its related operations and activities.

Table 13: Environmental Management Plan

Objective	Management Action	Responsibility	Time framework	Residual impact
Employment Opportunities				
To promote the employment of local persons	Recruitment of local workers will be undertaken without discrimination and in accordance with recruitment policy by contractors involved. The employment will be based on skills and working attitude that of industrial level.	Proponent /Contractor	On commencement of construction and operational activities	Unemployed people of area will get job opportunities and their standard of living will be improved
To promote the use of local service providers	Local procurement of goods and services will be undertaken wherever possible and cost effective and where practicable to the project	Proponent /Contractor	On commencement of construction and operational activities	Indirect job opportunities
Pollution control management				
To contain solid waste	<ul style="list-style-type: none"> • Proper maintenance of vehicles and equipment will be undertaken. • Appropriate environmental security measures including shovels and plastic bags etc will be provided to prevent accidental release to ground. • Appropriate procedures and protocols to be established and monitored for materials transport and handling whilst on the site. • Temporary waste bins will be provided for the solid waste which be managed as per municipality practices of the area. 	Contractor	Throughout project life	Potential for accidental release of materials during transport and handling on the site will be minimized.
Protection of biodiversity				
To avoid unnecessary disturbance of and quick recovery of biodiversity in the site	<ul style="list-style-type: none"> • Avoid destruction of biodiversity outside and inside the project area • Minimize clearing of vegetation 	Contactore	Throughout project life	Vegetation loss cannot be avoided, but successful restoration, improvement and long-term management of the surrounding

	<ul style="list-style-type: none"> • Prepare and implement an appropriate landscaping program to help in re-vegetation of affected project areas after construction • The flora of the site should be restored at the end of the phase by landscaping and planting native vegetation 			areas and maintenance of planted trees will provide significant compensation
Wastewater management				
During the performing activities chances of the groundwater water contamination are quite low	<ul style="list-style-type: none"> • Land disturbance will be minimized as much as possible. • Proper LPG storage techniques will be adopted to avoid leakage and to prevent the erosion of soils. • Drainage ditches will only be constructed where necessary. • Existing drainage systems / channels will not be altered. • Regular water sprinkling will be done to control fugitive dust emissions that may become cause the deterioration of the water resource. • Earthy materials and runoff should be handled in a manner that prevents adding suspended solids to flowing water which will prevents water pollution 	Contractor	Throughout project life cycle	None
Air quality and dust management				
The major source of air emissions is from extraction activities, emissions from the	<ul style="list-style-type: none"> • Fugitive dust emissions will be reduced significantly by converting the un-metaleed road to the stone road by using the aggregate. • Speed limits will be enforced to reduce airborne fugitive dust from vehicular traffic. 	Contractor	Throughout project life cycle	Localized minor effects on air quality at properties very close to certain roads, but increments a very small fraction of air quality criteria.

<p>transportation, generators.</p>	<ul style="list-style-type: none"> • Re-vegetation will be done to the disturbed areas as soon as possible after disturbance. • Regular water sprinkling will be done to suppress the fugitive dust emissions. • Training will be given to workers to handle loose materials and debris to reduce fugitive emissions. • Employment of water sprinkling will be done on all material as the most effective means of reducing the dust emission is wet suppression. Watering exposed surfaces and soil with adequate frequency to keep soil moist at all times can reduce the total dust emission from the project by as much as 75% • Dust emission from storage stockpiles will be reduced by covering the piles, for example with tarpaulin or thick plastic sheet • Good quality (low-sulfur) fuel will be used for vehicle and machinery • Provision of dust respirators to equipment operators who are exposed to dust while operating their equipment 			
Noise & vibration				
<p>To minimize disturbance of communities due to noise</p>	<ul style="list-style-type: none"> • No residential community is located within safe radius of the project area. So, no mitigation is required to reduce the impact on the community • Reducing equipment noise at source by proper design, maintenance and repair of machinery and equipment 	<p>Proponent / Contractor</p>	<p>Throughout project life cycle</p>	<p>Noise level will be based on PEQs</p>

	<ul style="list-style-type: none"> Noise from vehicles will be minimized by use of proper silencers and mufflers Hauling trucks shall be operated at low speed to minimize vibration, promote road safety, etc. Personal Protective Equipment (PPEs) should be given to the workers working on-site and wearing of the PPEs should be regulated strictly by the concerned authority Tree plantation may be done to reduce the impact habitats and fauna significantly 			
Land quality				
Accidental release of fuels, oils, materials, etc., to the ground	<ul style="list-style-type: none"> Appropriate procedures and protocols to be established and monitored for materials delivery and handling. Proponent will have, at all times, clean up kits available. All storage areas will have appropriate environmental security measures to prevent accidental release to ground. Appropriate procedures and protocols to be established and monitored for materials handling and use. Where possible, refueling and maintenance areas will include some form of secondary containment. 	Contractor / Proponent	Throughout project life cycle	Potential for accidental release of materials during use, handling and storage will be minimized/ controlled.
Ecology				
Disturbance of wildlife	<ul style="list-style-type: none"> No hunting, trapping and harassment policy will be adopted in case of fauna seen at the site Trading of the wild fauna will be strictly banned 	Contractor / Proponent	From start of operation	The project site does not have any sensitive species.

	<ul style="list-style-type: none"> • Rehabilitation and Re/Afforestation 			
HSE				
To minimize loss work injury/hazards/incidents/accidents	<ul style="list-style-type: none"> • Health and Safety SOPs will be enforced • Personal Protective Equipment (PPEs) will be given to the workers & wearing of the PPEs will be regulated strictly by the concerned authority • Exist route should be demarcated clearly • First aid kits and facilities to treat minor injuries should be present on-site • Routine free medical check-ups of the workers should be done on the regular basis • Ambulance and related equipment should be made available immediately in the case of emergency and in the case of the disaster • A Barr cation/stop sign will be put up on the access road to avoid any unfortunate incident • A low-speed limit for the access road will be enforced • Community complaints register, and other mean should be adopted for the community to complain. • All entry points into the area should be staffed 24 hour a day. People who are not related to the project should not be allowed inside. • No machinery should be left unattended, particularly in the running condition. • Placement of: <ol style="list-style-type: none"> i. DCP Fire Extinguishers 6kg (4) ii. DCP Fire Extinguishers 50 kg (2) 	Contractor / Proponent	Throughout life cycle of project	Potential of injuries will be minimized

	<p>iii. CO₂ Fire Extinguisher 5 Kg (2) iv. Halotron Fire Extinguisher (2) At different and easily accessible points. Provision of:</p> <ul style="list-style-type: none"> • Fire blankets (2) • Portable extension aluminum/fiber ladder (1) • Fireproof suit (2) • Gas protective goggles (4) • Face shield (4) • Gum boots (4 pairs) • Safety helmets (4) • Suitable gloves (4 pairs) • Portable torch (high beam) (2) • Breathing apparatus (1) • CCTV cameras (6) 			
--	--	--	--	--

7.4.1 Environmental Management Team

The proposed institutional arrangement for the implementation of EMMP is based on the discussions held with the Forest Department, Environmental Protection Department, Local Union Council Office and Proponent. The discussion concluded that three types of institutional arrangements are essential for the effective implementation of EMMP, these are follows:

- ⊗ Establishment of Environment/Social Management Group
- ⊗ External Monitoring by EPA certified laboratory
- ⊗ EMC established by Proponent after consultation with consultant.

a. Roles and Responsibilities

Following are the designated roles and responsibilities of the employees involved in the monitoring and management of the adverse impacts:

Table 14: Roles and Responsibilities

Roles and Responsibilities		
Sr#	Concerned Persons	Duties
1	The Project Manager	<p>Following will be the responsibilities of the Project Manager.</p> <ul style="list-style-type: none"> • Monitor the implementation of the EMMP throughout the project by means of site inspections and meetings. This will be documented as part of the minutes of the site meeting documents. • Ensuring project execution within defined budget and timelines • Conducting regular check of the project status and meetings with project team • Provide support and guidance to project team as and when needed. • Project Manager is expected to continually monitor and improve the overall performance of their operation.
2	HSE Manager	<p>In addition to the health and safety responsibilities held by staff, managers and supervisors must do whatever is reasonably practical to ensure that both the workplace and the work itself are safe. This includes:</p> <ul style="list-style-type: none"> • Ensuring that staff are appropriately trained and supervised. • Identifying, assessing, and managing health and safety risks • Consulting with workers (including staff, affiliates, and contractors): <ul style="list-style-type: none"> i. Health and safety risk assessments ii. Decisions are made about the measures to be taken to eliminate or control these risks. iii. Health and safety risk assessments • Implementing health and safety risk management programs relevant to their operations, teaching, research and consulting functions and work environment • Reporting (to the Human Resources Unit), investigating and responding to all hazards, accidents, incidents and taking action to control the risk.

		<ul style="list-style-type: none"> • Assisting with the development, implementation and maintenance of a return-to-work program for injured staff. • Be fully conversant with the EIA and conditions of its approval. • Be fully conversant with the EMMP. • Be fully conversant with all relevant environmental legislation, policies, and procedures, and ensure compliance. • Undertake regular and comprehensive inspection of the site and surrounding areas in order to monitor compliance with the EMMP. • Take appropriate action if the specifications contained in the EMMP are not followed. • Monitor and verify that environmental impacts are kept to a minimum, as far as possible. • Review and approve construction methods, with input from the Site Manager, where necessary • Ensure that activities on site comply with all relevant environmental legislation. • Compile progress reports on regular basis, with input from the Site Manager, for submission to the Project Manager, including a final post excavation audit. • Liaise with the Site Manager regarding the monitoring of the site. • Report any non-compliance or remedial measures that need to be applied • All environmental problems arising on the construction area will be reported to the Site Manager by the Environmental Manager. Reports on such problems will be submitted to the Project Manager by the Site Manager
--	--	---

7.4.2 Impacts Management and Monitoring Plans

The following environmental issues are considered to warrant specific management actions for the implementation of project. These issues have specific regulatory requirements (contained in the development consent or Environmental Approval) and/or are considered to have the potential to result in a non-compliance with a legislative requirement or generate community complaints.

7.5 Proposed Monitoring to Assess the Performance of EMP

An environmental monitoring plan provides a delivery mechanism to address the adverse environmental impacts of a project during its execution, to enhance project benefits, and to introduce standards of good practice to be adopted for all project works. An environmental monitoring program is important as it provides useful information and helps to:

- Assist in detecting the development of any unwanted environmental situation, and thus, provides opportunities for adopting appropriate control measures, and

- Define the responsibilities of the project proponents, contractors and environmental monitors and provides means of effectively communicating environmental issues among them.
- Define monitoring mechanism and identify monitoring parameters.
- Evaluate the performance and effectiveness of mitigation measures proposed in the Environment Management Plan (EMP) and suggest improvements in management plan, if required,
- Identify training requirement at various levels.

An environmental monitoring plan is suggested to monitor environmental parameters during survey, construction and post construction phase of the project.

Following environmental record should be maintained:

- Incident record of all moderate and major spills and other incidents and accidents. The record will include:

- ✓ Location of spill or Spilled material
- ✓ Estimated quantity or the amount of injury.
- ✓ Nature of injury or loss (temporary or permanent)
- ✓ Restoration measures
- ✓ Photographs
- Description of any damage to vegetation, water resource, or community asset.
- Corrective measures taken if any
- Waste Tracking Register that will hold records of waste generated during the construction period.

This will include quantities of waste disposed, recycled, or reused.

- Records of water consumption with usage breakdown
- Survey reports, in particular, the following:
 - ✓ Vehicle and equipment noise.
 - ✓ Ambient noise survey reports.
 - ✓ Ambient level of PM
 - ✓ Vendor data—all vendors disturbed by the project and compensation paid Public infrastructure: Record of all damages and repair work undertaken.
 - ✓ Employment
 - ✓ Total number of unskilled, semi-skilled, and skilled jobs offered during Construction.
 - ✓ Name and domicile of the employed staff.
 - ✓ Project and Community Interface
 - ✓ Record of community complains, and the measures taken to address them.
 - ✓ Number of meetings held in various communities and data of persons who attended
 - ✓ Environmental and social training records.

Table 15: Environmental Monitoring Plan

Components	Objective of Monitoring	Parameter to be Monitored	Measurement	Frequency	Location	Responsibility
Noise level (dB)	To check whether the existing noise control measures are able to bring the sound level within prescribed limits	Noise level near the receptor	Noise Measurement	Annual	Near the machinery working area & at a distance of 100 m	Environment officer
Emission of Gases and Particulates which may pollute the Environment	To determine the effectiveness of the Air Pollutants' abatement devices	Source Emission parameters	Ambient Air	Quarterly / Monthly (depending on frequency of operation)	Near the machinery working area & at a distance of 100 m	Environment Officer/Manager
Waste disposal, procedure for waste collection, storage, and disposal	To check the availability of waste management system and implementation	Inspection of waste management practices	Visual inspection	Per routine	Project area	Cleaning Department
Safety	To check and evaluate the effectiveness of the workers' safety plan and availability and access of first aid facilities	Injuries	Injuries being recorded	Daily	Entire working area	Health & Safety

7.6 SOCIAL MANAGEMENT PLAN

Based on the initial benchmark study, the following preliminary recommendations will be further adjusted according to the results of the Social Impact Assessment process to be conducted at a later stage:

- The management of the Project can capitalize on the positive attitude of the people of area towards proposed Project by offering them maximum employment opportunities based on the available skill and working attitude.
- Insufficient and inadequate socio –economic structure of the community of the area also provides ample opportunities to the Proponent to win sympathies of local people in their favor, by introducing meaningful and manageable plan of the community development.
- Extensive and comprehensive plantation plan can also lessen fear of local people towards environmental issues.
- Sustainable development approach through conservation of natural resources would be the best strategy to improve environment, conserve resources and strengthen ecological resilience.

- Proponent should offer technical training opportunities to the local youth, if possible, to improve technical knowledge at local level, engage young generation in fruitful activities and skill development and adequate time management.
- Socially responsible attitude and stewardship of Proponent towards local people and resources can make project more people friendly.
- To avoid any political, ethnic and value conflict, Proponent may win the confidence of local powerful elites, authorities, leaders and interest groups by adopting informal confidence building measures.

7.7 Proposed EMP Reporting and Reviewing Procedures

An effective mechanism to store and communicate environmental information during the project is an essential requirement of an EMP. The organizational structure for the Environment Management Plan is outlined below:

7.6.1 Primary Responsibilities

The primary responsibility for implementing different aspects of the EMP within the company lies with the Proponent / Contractor.

7.6.2 Operation Management & Control

Conducting the operational activities in environmentally sound manner will be the responsibility of the concerned Manager; for which he will be trained.

7.6.3 Supervision & Monitoring

Senior Supervisor will be responsible for all environmental issues and for the implementation of EMP.

7.6.4 Communications & Documentation

An effective mechanism to store and communicate environmental information during the project is an essential requirement of an EMP.

7.6.5 Meetings

As environment is multidisciplinary subject with environmentalist having a dynamic role therefore Environment Officer would be considered as integral part in both constructional and operational team. Participation of Environment Officer in daily morning meeting and any other special meeting is mandatory. Besides internal meeting HSE Engineer/Environment Officer is also responsible to conduct meeting with local in keeping administration in liaison.

7.6.6 Changes-Record Register

A change-record register will be maintained at the site, in order to document any changes in project design. These changes will be handled through the change management mechanism.

7.8 Training and Capacity Building

Training and capacity building trainings are conducted on the regular basis to enhance the capacity of the workers hired for the working. Following is the detailed plan along with the schedules of the training:

Table 16: Training and Capacity Building Plan

Training and Capacity Building Plan			
<i>Potential Impacts</i>	Operation Phase		
	During operational phase, nearby society and workers will face problems like: <ul style="list-style-type: none"> • Air Pollution • Noise Pollution • HSE • First Aid Training 		
<i>Mitigation</i>	Training and Capacity Building Plan		
<i>Management Plan</i>	Training and Capacity Building Plan Project will ensure training for the project staff, labour and the supervisory staff of the Proponent through the provision of one day basic training on recruitment and then on all needed skills, covering environmental and social aspects of the projects in general, and implementation requirements will emphasis on the development projects in general, and implementation requirements with emphasis on the roles and responsibilities of the staff and the labour while executing the environmental monitoring plan in particular. The training protocols will include the following aspects: <ul style="list-style-type: none"> ⇒ Procedures for monitoring the air quality parameters and measures to be adopted for avoiding or minimizing air pollution ⇒ Safe waste disposal practices ⇒ Safety measures against hazards for workforce and the local communities arising from the construction activities ⇒ Use of safety gadgets by the workforce 		
<i>Monitoring</i>	Responsibility	Responsible	Monitoring Duration
	Training of staff, vehicle operators and labour	Project Manager / Operations Manager	Once on recruitment then on required skill.

7.9 Equipment Maintenance Details

The Client and Contractor will be responsible to maintain equipment with higher efficiency and in good working conditions. The equipment will be maintained twice a year as well as monthly inspection will be done on the regular basis to keep the process going without any interruption.

7.10 Environmental Budget

Approximately 0.2 million PKR per year budget will be reserved for the Environmental Monitoring and measures. It will also include cost for plantation, providing PPEs and HSE trainings.

7. PUBLIC CONSULTATION AND INFORMATION DISCLOSURE

Public consultation refers to the process by which the concerns of local affected persons and others who have a plausible stake in the environmental impacts of the project or activity are ascertained with a view to taking into account all the material concerns in the project or activity design as appropriate. According to the IEE and EIA Review Regulations, public consultation is mandatory for any socio-environmental study.

8.1 Proponent’s Environmental Management Team

Following are the designated roles and responsibilities of the employees involved in the monitoring and management of the adverse impacts and will be appointed after operation of project starts.

Roles and Responsibilities		
Sr#	Concerned Persons	Duties
1	The Project Manager	<p>Following will be the responsibilities of the Project Manager.</p> <ul style="list-style-type: none"> • Ensure that the contractor is aware of all specifications, legal constraints, standards, and procedures pertaining to the project specifically with regards to environment. • Ensure that all stipulations within the EMMP are communicated and adhered to by contractor(s) • Monitor the implementation of the EMMP throughout the project by means of site inspections and meetings. This will be documented as part of the minutes of the site meeting documents. • Ensuring project execution within defined budget and timelines • Conducting regular check of the project status and meetings with project team • Provide support and guidance to project team as and when needed. • Project Manager is expected to continually monitor and improve the overall performance of their operation
2	HSE Manager	<p>In addition to the health and safety responsibilities held by staff, managers and supervisors must do whatever is reasonably practical to ensure that both the workplace and the work itself are safe. This includes:</p> <ul style="list-style-type: none"> • Ensuring that staff are appropriately trained and supervised. • Identifying, assessing, and managing health and safety risks • Consulting with workers (including staff, affiliates, and contractors): <ol style="list-style-type: none"> 1. Health and safety risk assessments 2. Decisions are made about the measures to be taken to eliminate or control these risks. 3. Health and safety risk assessments • Implementing health and safety risk management programs relevant to their operations, teaching, research and consulting functions and work environment • Reporting (to the Human Resources Unit), investigating and responding to all hazards, accidents, incidents and taking action to control the risk. • Assisting with the development, implementation, and maintenance of a return-to-work program for injured staff. • Be fully conversant with the EIA and conditions of its approval. • Be fully conversant with the EMMP.

		<ul style="list-style-type: none"> • Be fully conversant with all relevant environmental legislation, policies and procedures, and ensure compliance. • Convey the contents of this document to the contractor site staff and discuss the contents in detail with the Project Manager and Contractor • Undertake regular and comprehensive inspection of the site and surrounding areas in order to monitor compliance with the EMMP. • Take appropriate action if the specifications contained in the EMMP are not followed. • Monitor and verify that environmental impacts are kept to a minimum, as far as possible. • Review and approve construction methods, with input from the Site Manager, where necessary. • Ensure that activities on site comply with all relevant environmental legislation. • Compile progress reports on regular basis, with input from the Site Manager, for submission to the Project Manager, including a final post excavation audit. • Liaise with the Site Manager regarding the monitoring of the site. • Report any non-compliance or remedial measures that need to be applied. • All environmental problems arising on the construction area will be reported to the Site Manager by the Environmental Manager. Reports on such problems will be submitted to the Project Manager by the Site Manager.
--	--	--

8.2 The Responsible Authority

Impact assessment survey and public consultation sessions held with different stakeholder groups that may be impacted by the proposed project commencement. The consultation process was carried out in accordance with the guidelines laid by Punjab-EPA. The objectives of this process were to:

- Share information with stakeholders on proposed project installation and operation.
- Access the impacts on the physical, biological, and socioeconomic environment.
- Understand stakeholder concerns regarding various aspects of the project commencement.
- Find out valuable suggestions by the stakeholders to improve the proposed project design.
- Understand the perceptions, assessment of social impacts and concerns of the affected people/communities of the project area.
- Find out the awareness level and situation of acceptability to identify any issues for the implementation of the proposed project.
- Invite people to express their views about the positive/negative impacts on their lifestyles and environment.
- Disclose information about contact offices/officers for any complaints/queries.

It is envisaged, there will be no social impact being foreseen due to the construction and operation of Marhaba LPG Traders (PVT) Limited at the proposed location. Galo is the nearest community located at 775 Meterseters distance from the project area. This EIA Report includes all the comments, which were

taken into account during the social survey and preparing the definitive development concept for the installation and operation of LPG Storage & Filling Plant.

8.3 Objectives of Consultation

Public consultation plays a vital role in studying the impacts of the proposed project on stakeholders in successful implementation and execution of the project. It provides an opportunity to exchange knowledge with the beneficiaries and affected parties. Referring particularly to a project related to environmental assessment, involvement of the public is all the more essential, as it leads to better and more acceptable decision-making. The overall objective of the consultation with the stakeholders is to help verify the environmental and social issues, besides technical ones, that have been presumed to arise and to identify those which are not known or are specific to the project. In fact, discourse with many who have thoroughly observed the site conditions in the pre-development phase, goes a long way in updating the knowledge and understanding.

8.4 Identification of Stakeholders

All the people who are directly or indirectly affected or concerned with the project are the stakeholder. Besides the living population of the surrounding areas, some other stakeholders were identified and contacted which enlisted below. They are the key players including shops, public and government offices, schools, university, hospitals, hotels, international agencies and the NGOs. Not only published material, brief or other literature were obtained on request, but also noted their views and the concerns, in an official capacity as well as on the personal basis. Following stakeholders are identified for this project:

Project Affected Persons (PAPs) include the settled families, either property owners or the tenants, businessmen (big, shopkeepers, vendors, etc.), employees of the commercial entities. PAPs are of two types, for instance:

8.5 Direct Stakeholders

No disturbance in the local community is being foreseen due to the installation of the gear manufacturing unit as the distance between the community and the project area is 775 Meterseters (Galo). No property loss is being envisaged due to the construction of the Marhaba LPGTraders (PVT) Limited.

8.5.1 Indirect Stakeholders

Indirect impact will occur on those who are living or doing business within a Project Area of Influence (AOI). In the case of the proposed project, the citizens of nearby Galo will get opportunities of being employed. So, in the early development stages and during the operational phase the people will be benefited due to the installation of the Marhaba LPGTraders (PVT) Limited.

8.5.2 Other Departments and Agencies

Following departments are related to the project in public consultation:

- ⇒ Government agencies responsible to deal with the project related activities.

- ⇒ Government Agencies directly, indirectly, or widely involved in the execution and monitoring of the proposed project.
- ⇒ Government departments such as TMA and Planning & Development Department, Forest Department, Agricultural Department, petroleum and working on the other development activities are considered as indirect stakeholders.
- ⇒ Workers of political, cultural, religious, or social scientific bodies, directly or indirectly related to the project.

8.6 Public Disclosure

Public disclosure is the outcome of all such activities where the public is involved at least in the information sharing process. This is an integral part of the process. So, before the proponent applies for NOC to the Punjab-EPA, this disclosure will be distributed properly among all stakeholders. It is the responsibility of the proponent and the consultants to display a public disclosure document in prominent places where community has easy access.

8.7 Consultation Process

Information disclosure, public consultation, and discussion regarding the various aspects of the project with the people of the area are necessary. This process is intensified during the EIA Studies, and separate rounds of public consultations were held. Surveys were carried out in order to investigate physical, biological and socioeconomic resources falling within the immediate AOI of the project. Primary data collection included:

- Data collection regarding the socioeconomic condition of the study area
- Pre-testing of socioeconomic survey tools in the field
- To consult the locals for collection of information on biological environment

Various meetings with the stakeholders were held the following objectives:

- Share information with stakeholders on the proposed project and expected impacts on community in the vicinity of the project.
- Understand stakeholders' concerns regarding various aspects of the project, including the existing condition of the upgrading requirements, and the likely impact of construction and operation activities.
- Provide an opportunity to the public to influence the project design in a positive manner.
- Obtain local and traditional knowledge, before decision making.
- Increase public confidence about the proponent, reviewers, and decision makers.
- Reduce conflict through the early identification of controversial issues, and work through them to find acceptable solutions.
- Dissemination of information through discussions, education, and liaison

- Documentation of information narrated by the stakeholders and mitigation measures proposed by the stakeholders.
- Incorporation of public concerns and their address in the EIA; and eliciting their comments and feedback.
- Create a sense of ownership of the proposal in the mind of the stakeholders.

8.8 Environmental Practitioners and Experts

Officers of government departments, Educational Institutes, Lawyers and NGOs were consulted by the socio-environmental team of the consultants and concerned details about the project were noted down through personal interviews, group meetings, etc., in their offices, for instance.

8.9 Affected and Wider Community

In addition, to the use of direct methods to evince the response of the various stakeholders in the population of the study area was ascertained by conducting a sample survey. Questions posed to the public were related to creation of possible impacts, adverse impacts and beneficial impacts, including employment opportunities, income generation activities, change in living standards and provision of the amenity.

- ➔ Disclose the proponent plan of the construction of the proposed facility.
- ➔ To share information on the design and specifications of proposed project works
- ➔ To analyze the expected impact on the socioeconomic environment
- ➔ To understand their concerns regarding various aspects of construction and operation

7.9.1 Views, Concerns and Suggestions of Various Stakeholders

Community showed a lot of concerns; a few are being mentioned here:

- Removal of shrubs and trees should be avoided to the extent possible
- The project will become the source of income for local to earn their livelihood easily and honorably.
- The area will become further commercialized.
- For the solid waste management and waste disposal, proper disposal techniques should be adopted.
- Employment opportunities will be generated, and locals should be hired on the priority basis.
- The air pollution is one of the major impacts of the proposed project, so ambient air quality should be monitored regularly.
- Water spraying/sprinkling should be done on the regular basis during construction phase to avoid dust emissions.
- Good relations with the local communities will be promoted by encouraging Contractor to provide opportunities for skilled and unskilled employment to the locals as well as on-job training.
- The contractor should prefer hiring local labor from adjacent nearby villages.
- Indigenous trees around the facility should be planted to control air pollution and as the compensation.

- Noise reducing barriers should be installed to reduce noise pollution.

8.10 Addressing Public Concerns

The best mechanism of effective communication between the community and the proponent is the by the nomination of the representative of the community and all the issues/concerns must be recorded for future reference. This representative may be the member of the Grievances Redressed Committee (GRC).

a) Grievances Redressed Committee

Grievances Redressed Committee (GRC) will be formulated by the proponent to address the concerns of the locals during the construction phase. The main role of the GRC will be to resolve the issues of the community associated with the proposed project, if any.

8.11 Acceptance Level of the Project

The opinions of the respondents were noted during the public consultation. The majority of respondents (90%) of Galo were in favor of the proposed project. They expect that installation of the unit will also increase the economic value of local assets. According to them the proposed project will boost the employment opportunities, mobility access to resources and social amenities.

CHAPTER 8. CONCLUSION AND RECOMMENDATIONS

The findings of EIA Report showed that although The Marhaba LPG Traders (PVT) Limited is expected to have significant negative impacts on the environment during the construction and operational phases, but the severity of these adverse impacts can be reduced significantly by adopting the suggested mitigation measures in EMMP with true spirit. Moreover, their severity can be further reduced by adopting relative mitigation measures as proposed in the Chapter 5 of this EIA Report. The impacts were assessed by frequent site visits, studying related projects and by reviewing relevant documents. Generally, the project is planned to follow efficient environmental management systems. Specific environmental and social benefits have been mentioned below which depend on the proper application of mitigation measures suggested in EMMP and best engineering practices.

9.1 Merits and Demerits

The major positive impacts include increased job opportunities, business opportunities, and environmental enhancement through tree plantation. The project will raise the income of the persons directly associated with project as well as it will also improve the socio-economic status of the area. In general, potential adverse environmental effects resulting from the proposed activities will be temporary in nature, short-term and of low magnitude. Through application of standards, recommended mitigation measures, adherence to applicable permit conditions and regulations, adverse impacts can be effectively minimized. The project is not likely to have significant adverse environmental impacts which cannot be mitigated. Negligible negative impacts that are likely occur during construction of building includes air pollution due to movements of vehicles, removal of bushes and shrubs, potential impact to the local water resources and social impacts may affect the locals residing in the nearby community can be foreseen. Mitigation measures will be implemented to minimize environmental impacts though they are still negligible. There are certain mitigations suggested to cater for the aforesaid issues.

9.2 Recommendations

The intensity and severity of impacts occurred due to the establishment Marhaba LPG Traders (PVT) Limited varies with change in the nature and magnitude of the project as well as depends upon the baseline environmental conditions of the area. The mitigation measures will require constant information flow and consultation with the stakeholders to ensure the least adverse social-economic impact to outweigh the “no project development” scenario.

- ➔ The adverse environmental impacts can be reduced significantly by adopting best management and monitoring practices as well as by implementation EMMP with true spirit.
- ➔ Proper PPEs including aprons, rubber gloves and shoes should be provided to workers.
- ➔ No compromise on public health and environment should be allowed.

- ➔ Waste minimization practices should be introduced to workers by conducting lectures on spot to aware the workers about the long-term benefits of the same in lieu of surrounding environment.
- ➔ A proper tree plantation plan should also be developed in order to make the process environment friendly.
- ➔ Small domestic waste storage bins should be placed at different locations for proper collection and disposal of the solid waste.
- ➔ It is recommended that the Proponent should obtain an Environmental Approval (NOC) from the Punjab-EPA before proceeding further.

GLOSSARY

Agency	A business or organization providing a particular service on behalf of another business, person, or group.
Climate	The weather conditions prevailing in an area in general or over a long period.
Consultant	A person who provides professional advice or services to companies for fee.
Construction Waste	Waste generated from the buildings and construction industry and includes material like bricks, concrete, tiles, debris, ceramics and more.
Demographic	A single vital or social statistic of a human population, as the number of births or deaths.
Ecology	The branch of biology that deals with the relations of organisms to one another and to their physical surroundings.
Endangered species	A species of animal or plant that is seriously at risk of extinction.
Environment	Relationship of natural world (human beings, animals and plants) with physical surroundings (air, land, water).
Excavation	Excavation is the act or process of digging, especially when something specific is being removed from the ground. Archaeologists use excavation to find artifacts and fossils.
Filling Station	A place equipped for servicing automobiles, as by selling gasoline
Framework	A framework is a real or conceptual structure intended to serve as a support or guide for the building of something that expands the structure into something useful.
Hazardous Waste	Hazardous Waste is waste that poses substantial or potential threats to public health or environment.
Impact	The action of one object coming forcibly into contact with another.
Livelihood	A set of activities involving Securing the basic necessities –food, water, shelter and clothing of life.
Municipal Waste	Municipal Solid Waste (MSW)—more commonly known as trash or garbage—consists of everyday items we use and then throw away, such as product packaging, grass clippings, furniture, clothing, bottles, food scraps, newspapers, appliances, paint, and batteries. This comes from our homes, schools, hospitals, and businesses.

Nature	The phenomena of the physical world collectively, including plants, animals, the landscape, and other features and products of the earth, as opposed to humans or human creations.
Proponent	A person who advocates a theory, proposal, or course of action.
Rehabilitation	To restore to a condition of good health, ability to work, or the like.
Resettlement	The settlement of people in a different place.
Sanitation	Conditions relating to public health, especially the provision of clean drinking water and adequate sewage disposal.
Stakeholder	A stakeholder is a party that has an interest in a company and can either affect or be affected by the business. The primary stakeholders in a typical corporation are its investors, employees, and customers.
Topography	Topography is the study of the shape and features of the surface of the Earth and other observable astronomical objects including planets, moons, and asteroids.
Vegetation	Plants considered collectively, especially those found in a particular area or habitat.

LIST OF ABBREVIATIONS

AOI	Area of Interest
°C	Degree Celsius
CO ₂	Carbon dioxide
EIA	Environmental Impact Assessment
IEE	Initial Environmental Examination
EMMP	Environmental Management and Monitoring Plan
EMP	Environmental Management Plan
EPA	Environmental Protection Agency
EPD	Environmental Protection Department
GRC	Grievances Redressed Committee
HSE	Health and Safety Engineer
LPG	Liquefied Petroleum Gas
m ³	Cubic meter
m ³ /h	Cubic meter per hour
GEPCO	Gujranwala Electric Power Company
NEQS	National Environmental Quality Standards
No.	Number
NOC	No Objection Certificate
NO _x	Oxides of Nitrogen
PEPA, 2012	Punjab Environmental Protection (Amendment) Act, 2012
PEPO	Pakistan Environmental Protection Ordinance
PKR	Pakistani Rupees
PM	Particulate Matter
PPEs	Personal Protective Equipment
QA	Quality Assurance
RO	Reverse Osmosis
SOPs	Standard Operation Procedures
TMA	Town Municipal Authority
WWTP	Wastewater treatment Plant

LIST OF PEOPLE CONSULTED

Sr. No.	Name	Fathers' name	CNIC	Concerns/views
1	Saqib Ali	Riaz Ali	35202-4225635-9	Positive
2	Muhammad Shabbir Ali	Syed Farooq	35201-6650791-1	Positive
3	Mohsin Mahmud Dar	Irfan Dar	35202-2607775-3	Positive
4	Haider Muzaffar	Muhamad Muzzafar	35202-4567566-3	Concerned about Water pollution
5	Abdul Khurram	Khurram Imtiaz	35202-3483674-5	Concerned about Air pollution
6	Umar Ali	Faisal Manzoor	35202-2701116-1	Positive
7	Jawad Ahmed	Muhammad Boota	35202-4202245-7	Positive
8	Azhar Aziz	Nisar Ahmed	34401-5144918-9	Positive
9	Behzad Taimur	Muhammad Taimur	38401-6768711-1	Positive
10	Aslam Pasha	Bilal Pasha	34401-0223636-3	Positive

LIST OF ORGANIZATIONS CONSULTED

Name	Organization	Feedback
Mehtab Ahmad	Officer EHS PHP Makhdoom Rasheed	The provision of quality LPG Storage & Filling Plant in affordable prices is necessary for smooth market operations.
Arbaz Shaheen	Production Manager PSO Gas Station	Establishment of this unit must be favored It will help in boosting economy of our country.
Mr. Haroon	S.D.O WAPDA	The demand for LPG, locally, is consistently increasing, it will eventually help in handling the higher demand as well as increase employment opportunities and economy of the area.
M. Arshad	Assistant Director EIA EPA, Punjab	Such facility will greatly help in reducing pressure of job availability.

Sources of Data

- ⇒ <https://www.pmd.gov.pk/en/>
- ⇒ <http://www.agripunjab.gov.pk/>
- ⇒ <https://www.sciencedirect.com/topics/engineering/denim-fabric>
- ⇒ Demirbas, A. (2002). Fuel properties of hydrogen, liquefied petroleum gas (LPG), and compressed natural gas (CNG) for transportation. *Energy Sources*, 24(7), 601-610.
- ⇒ Raslavičius, L., Keršys, A., Mockus, S., Keršienė, N., & Starevičius, M. (2014). Liquefied petroleum gas (LPG) as a medium-term option in the transition to sustainable fuels and transport. *Renewable and Sustainable Energy Reviews*, 32, 513-525.
- ⇒ Mistry, C. S. (2005). Comparative assessment on performance of multi cylinder engine using CNG, LPG and Petrol as a fuel. *SAE transactions*, 222-226.
- ⇒ Irfan, M., Cameron, M. P., & Hassan, G. (2018). Household energy elasticities and policy implications for Pakistan. *Energy Policy*, 113, 633-642.
- ⇒ Nayyar, Z. A., Zaigham, N. A., & Qadeer, A. (2014). Assessment of present conventional and non-conventional energy scenario of Pakistan. *Renewable and Sustainable Energy Reviews*, 31, 543-553.
- ⇒ <https://www.geo.tv/latest/375731-pakistan-plans-to-enter-into-long-term-lpg-supply-contracts-with-other-countries>
- ⇒ Field Surveys
- ⇒ Public Consultations

TERMS OF REFERENCE (TORS)

The consultants are required to carry out an Initial Environmental Examination study of the project under Section-12 of Pakistan Environmental Protection Act 1997/ Punjab Environmental Protection (Amendment) Act 2012.

The Study should be comprehensive and should cover all aspects which are envisaged under the relevant national and provincial laws & regulations including but not limited to:

- Identification and recommendation for suitable solution/treatment/mitigation measures for emissions and effluents such as wastewater and sludge etc. in accordance with Punjab Environmental Quality Standards (PEQS).
- Identification and recommendation for suitable solution/treatment/mitigation measures of solvents, oils (tar), hazardous waste, organic compounds, steam, flue gases, particulate matter and chemical compounds harmful for the environment and other substances leading to air, noise, water and soil pollution in accordance with PEQS.

The Study should be acceptable to the relevant national and/or provincial authorities (relevant authorities) in Punjab.

PROJECT TEAM AND RESPONSIBILITIES

Name of expert	Position held	Highest Qualification	TERM OF REFERENCES
Kamal Ahmed Cheema	Chief Environmentalist	M. Phil. Environmental Economics, PIDE, Islamabad	Mr. Kamal would be responsible for: <ul style="list-style-type: none"> ❖ Environmental Assessment & Management. ❖ Supervision of monitoring team for air water noise and soil analysis. ❖ Preparation of technical EMP
Mr. Shahzaib Ahmed	Social Scientist	M. Phil Development Studies, PIDE, Islamabad.	Mr. Shahzaib would be responsible for: <ul style="list-style-type: none"> ❖ Detailed social survey of project sites ❖ Social impact assessment
Arslan Iqbal	Environmentalist-2	MPhil Environmental Sciences, UOL	Mr. Arslan would be responsible for: <ul style="list-style-type: none"> ❖ Biodiversity assessment ❖ Detailed flora fauna survey of project sites ❖ Identification of threaten and endangered species ❖ Project impacts on flora and fauna ❖ Detailed social survey of project sites ❖ Social impact assessment ❖ Consultation with stakeholders
Amna Hafeez	Environmentalist-3	M.Sc. Mountain Conservation and Watershed Management, University of the Punjab	Ms. Amna would be responsible for: <ul style="list-style-type: none"> ❖ Report writing ❖ Field surveys and consultation with stakeholders ❖ Preparation of Environment monitoring plan ❖ Preparation of technical EMP ❖ Identification of sensitive receptors ❖ Capacity building & training ❖ Conducting and monitoring of health assessment surveys

			<ul style="list-style-type: none"> ❖ Environment health risk assessment and management ❖ Detailed survey of project sites ❖ Environmental Assessment ❖ Social Assessment
Rahma Butt	Environmental-4	BS (Hons) Environmental Science, Lahore College for Women University.	<p>Ms. Rahma would be responsible for:</p> <ul style="list-style-type: none"> ❖ Detailed flora and fauna survey of project sites ❖ Site Monitoring ❖ Socio-Economic survey & analysis ❖ Report Writing
Saba Nazir	Environmental-5	M.phil Environmental Sciences, UOL	<p>Ms. Saba would be responsible for:</p> <ul style="list-style-type: none"> ❖ Site Monitoring ❖ Socio-Economic survey & analysis ❖ Risk Assessment (OHS & EMP) ❖ Report writing
Aishah Mushtaq	Environmental-6	M S Environmental Sciences, LCWU	<p>Ms. Saba would be responsible for:</p> <ul style="list-style-type: none"> ❖ Risk Assessment (OHS & EMP) ❖ Report writing